

FOOD & KITCHEN



whisk

Utensil made of several curved and intersecting steel wires used to blend, beat or whip liquid and semiliquid ingredients.



green onion

Mild onion picked before fully ripe; it is usually sold with the stem, in bunches. It is often eaten raw in salads or cooked in sautéed dishes.

FOOD & KITCHEN

Jean-Claude **Corbeil**
Ariane **Archambault**

ACKNOWLEDGEMENTS

Our deepest gratitude to the individuals, institutions, companies, and businesses that have provided us with the latest technical documentation for use in preparing this dictionary.

Arcand, Denys (motion picture director); International Association of Marine Aids to Navigation and Lighthouse Authority; Canadian Payments Association (Charlie Clarke); Canadian Bankers Association (Lise Provost); Automobiles Citroën; Automobiles Peugeot; Bank of Canada (Lyse Brousseau); Royal Bank of Canada (Raymond Chouinard, Francine Morel, Carole Trottier); Barrett Xplore inc.; Bazzarin, Christine; Library of Canadian Parliament (Information Services); Bibliothèque nationale du Québec (Jean-François Palomino); Bluechip Kennels (Olga Gagne); Bombardier Aerospace; Bridgestone-Firestone; Brother (Canada); Canadian National; Casavant Frères Ltée; C.O.J.O. ATHENS 2004 (International Media Service); Centre Eaton de Montréal; Centre national du costume (Recherche et diffusion); Cetacean Society International (William R. Rossiter); Chagnon, Daniel (architect D.E.S. - M.E.Q.); Cohen et Rubin Architectes (Maggy Cohen); Commission scolaire de Montréal (École St-Henri); Hudson Bay Company (Nunzia Iavarone, Ron Oyama); Corporation d'hébergement du Québec (Céline Drolet); National Theatre School of Canada (Library); Élevage Le Grand Saphir (Stéphane Aytte); Atomic Energy of Canada; Eurocopter; Famous Players; Fédération bancaire française (Védi Hékiman); Fontaine, Pierre-Henry (biologist); Future Shop; Garaga; Groupe Jean Coutu; Hôpital du Sacré-Cœur de Montréal; Hôtel Inter-Continental; Hydro-Québec; I.P.I.Q. (Serge Bouchard); IGA Barcelo; International Entomological Society (Dr. Michael Geisthardt); Irisbus; Jérôme, Danielle (O.D.); La Poste (Colette Gouts); Le Groupe Canam Manac inc.; Lévesque, Georges (urgentologist); Lévesque, Robert (chief machinist); Manutan; Marriott SpringHill Suites; MATRA S.A.; Métro inc.; National Defence of Canada (Public Affairs); ministère de la Défense, République Française; ministère de la Justice du Québec (Service de la gestion immobilière - Carol Sirois); ministère de l'Éducation du Québec (Direction de l'équipement scolaire - Daniel Chagnon); Muse Productions (Annick Barbery); National Aeronautics and Space Administration; National Oceanic and Atmospheric Administration; Nikon Canada inc.; Normand, Denis (telecommunications consultant); Office de la langue française du Québec (Chantal Robinson); Paul Demers & Fils inc.; Phillips (France); Pratt & Whitney Canada inc.; Prévost Car inc.; Radio Shack Canada Ltée; Réno-Dépôt inc.; Robitaille, Jean-François (Department of Biology, Laurentian University); Rocking T Ranch and Poultry Farm (Pete and Justine Ther); RONA inc.; Sears Canada inc.; Public Works and Government Services Canada: Translation Bureau; Correctional Service Canada; Société d'Entomologie Africaine (Alain Drumont); Société des musées québécois (Michel Perron); Société Radio-Canada; Sony du Canada Ltée; Sûreté du Québec; Théâtre du Nouveau Monde; Transport Canada (Julie Poirier); Urgences-Santé (Éric Berry); Ville de Longueuil (Direction de la Police); Ville de Montréal (Service de la prévention des incendies); Vimont Lexus Toyota; Volvo Bus Corporation; Yamaha Motor Canada Ltd.

Food & Kitchen was created and produced by

ISBN 978-2-7644-0878-0



QA International

329 De la Commune West, 3rd Floor
Montreal (Quebec) H2Y 2E1 Canada
T 514.499.3000 F 514.499.3010

www.qa-international.com

© QA International 2009. All rights reserved.

No part of this book may be reproduced or transmitted in any form or by any means, electronic or mechanical, including photocopying, recording, or by any information storage and retrieval system, without permission in writing by QA International.

Printed and bound in Singapore
10 9 8 7 6 5 4 3 2 1 12 11 10 09

www.qa-international.com

Version 3.5.1

EDITORIAL STAFF

Editor: Jacques Fortin
Authors: Jean-Claude Corbeil and
Ariane Archambault
Editorial Director: François Fortin
Editor-in-Chief: Anne Rouleau
Graphic Designer: Anne Tremblay

PRODUCTION

Nathalie Fréchette
Josée Gagnon

TERMINOLOGICAL RESEARCH

Jean Beaumont
Catherine Briand
Nathalie Guillo

ENGLISH DEFINITIONS

Nancy Butchart
Rita Cloghesy
Tom Donovan
Diana Halfpenny
John Woolfrey
Kathe Roth

ILLUSTRATIONS

Artistic Direction: Jocelyn Gardner
Jean-Yves Ahern
Rielle Lévesque
Alain Lemire
Mélanie Boivin
Yan Bohler
Claude Thivierge
Pascal Bilodeau
Michel Rouleau
Anouk Noël
Carl Pelletier
Raymond Martin

CONTRIBUTIONS

QA International wishes to extend a special thank you to the following people for their contribution to this book:

Jean-Louis Martin, Marc Lalumière, Jacques Perrault, Stéphane Roy, Alice Comtois, Michel Blais, Christiane Beaugard, Mamadou Togola, Annie Maurice, Charles Campeau, Mivil Deschênes, Jonathan Jacques, Martin Lortie, Frédéric Simard, Yan Tremblay, Mathieu Blouin, Sébastien Dallaire, Hoang Khanh Le, Martin Desrosiers, Nicolas Oroc, François Escalmel, Danièle Lemay, Pierre Savoie, Benoit Bourdeau, Marie-Andrée Lemieux, Caroline Soucy, Yves Chabot, Anne-Marie Ouellette, Anne-Marie Villeneuve, Anne-Marie Brault, Nancy Lepage, Daniel Provost, François Vézina, Guylaine Houle, Daniel Beaulieu, Sophie Pellerin, Tony O'Riley, Mac Thien Nguyen Hoang, Serge D'Amico.

LAYOUT

Pascal Goyette
Danielle Quinty
Émilie Corriveau
Preliminary layout: Émilie Bellemare
Sonia Charette

DOCUMENTATION

Gilles Vézina
Kathleen Wynd
Stéphane Batigne
Sylvain Robichaud
Jessie Daigle

DATA MANAGEMENT

Programmer: Éric Gagnon
Josée Gagnon

REVISION

Veronica Schami
Jo Howard
Marie-Nicole Cimon
Liliane Michaud

PREPRESS

Karine Lévesque
François Hénault
Julien Brisebois
Patrick Mercure

INTRODUCTION

EDITORIAL POLICY

The Visual Dictionary takes an inventory of the physical environment of a person who is part of today's technological age and who knows and uses a large number of specialized terms in a wide variety of fields.

Designed for the general public, it responds to the needs of anyone seeking the precise, correct terms for a wide range of personal or professional reasons: finding an unknown term, checking the meaning of a word, translation, advertising, teaching material, etc.

The target user has guided the choice of contents for *The Visual Dictionary*, which aims to bring together in 12 thematic books the technical terms required to express the contemporary world, in the specialized fields that shape our daily experience.

STRUCTURE

Each tome has three sections: the preliminary pages, including the table of contents; the body of the text (i.e. the detailed treatment of the theme); the index.

Information is presented moving from the most abstract to the most concrete: sub-theme, title, subtitle, illustration, terminology.

TERMINOLOGY

Each word in *The Visual Dictionary* has been carefully selected following examination of high-quality documentation, at the required level of specialization.

There may be cases where different terms are used to name the same item. In such instances, the word most frequently used by the most highly regarded authors has been chosen.

Words are usually referred to in the singular, even if the illustration shows a number of individual examples. The word designates the concept, not the actual illustration.

DEFINITIONS

Within the hierarchical format of *The Visual Dictionary's* presentation, the definitions fit together like a Russian doll. For example, the information within the definition for the term *insect* at the top of the page does not have to be repeated for each of the insects illustrated. Instead, the text concentrates on defining the distinguishing characteristics of each insect (the *louse* is a parasite, the female *yellow jacket* stings, and so forth).

Since the definition leaves out what is obvious from the illustration, the illustrations and definitions complement one another.

The vast majority of the terms in the *Visual Dictionary* are defined. Terms are not defined when the illustration makes the meaning absolutely clear, or when the illustration suggests the usual meaning of the word (for example, the numerous *handles*).

METHODS OF CONSULTATION

Users may gain access to the contents of *The Visual Dictionary* in a variety of ways:

- From the TABLE OF CONTENTS at the end of the preliminary pages, the user can locate by title the section that is of interest.
- With the INDEX, the user can consult *The Visual Dictionary* from a word, so as to see what it corresponds to, or to verify accuracy by examining the illustration that depicts it.
- The most original aspect of *The Visual Dictionary* is the fact that the illustrations enable the user to find a word even if he or she only has a vague idea of what it is. The dictionary is unique in this feature, as consultation of any other dictionary requires the user first to know the word.

TITLE

Its definition is found below. If the title refers to information that continues over several pages, after the first page it is shown in a shaded tone with no definition.

DEFINITION

It explains the inherent qualities, function, or characteristics of the element depicted in the illustration.

TERM

Each term appears in the index with a reference to the pages on which it appears.

SUB-THEME

These are shown at the end of the preliminary pages along with their definitions. They are then repeated on each page of a section, but without the definition.

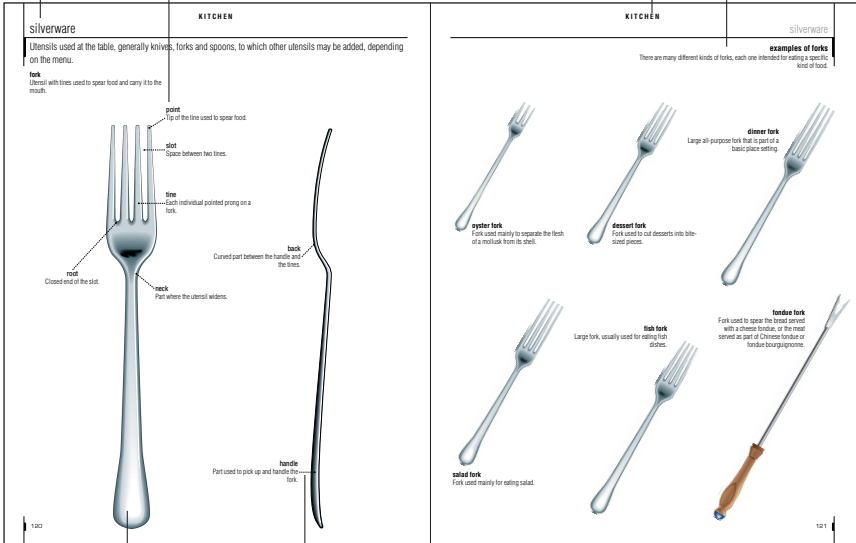

ILLUSTRATION

It is an integral part of the visual definition for each of the terms that refer to it.

NARROW LINES

These link the word to the item indicated. Where too many lines would make reading difficult, they have been replaced by color codes with captions or, in rare cases, by numbers.

CONTENTS

8 FOOD

- 8 Farmstead
- 10 Supermarket
- 12 Restaurant
- 16 Mushrooms
- 18 Seaweed
- 19 Vegetables
- 36 Legumes
- 41 Fruits
- 54 Spices
- 58 Condiments
- 62 Herbs
- 64 Cereal
- 66 Cereal products
- 76 Coffee and infusions
- 78 Chocolate
- 79 Sugar
- 80 Fats and oils
- 81 Dairy products
- 87 Eggs
- 88 Variety meat
- 89 Game
- 90 Poultry
- 91 Delicatessen
- 94 Meat
- 98 Mollusks
- 100 Crustaceans
- 101 Cartilaginous fishes
- 102 Bony fishes

108 KITCHEN

- 108 Packaging
- 112 Kitchen
- 114 Glassware
- 116 Dinnerware
- 120 Silverware
- 126 Kitchen utensils
- 141 Cooking utensils
- 146 Domestic appliances
- 162 Miscellaneous domestic appliances
- 165 Coffee makers

169 INDEX

farmstead

All the structures belonging to an agricultural concern and used as dwellings or in its operation.

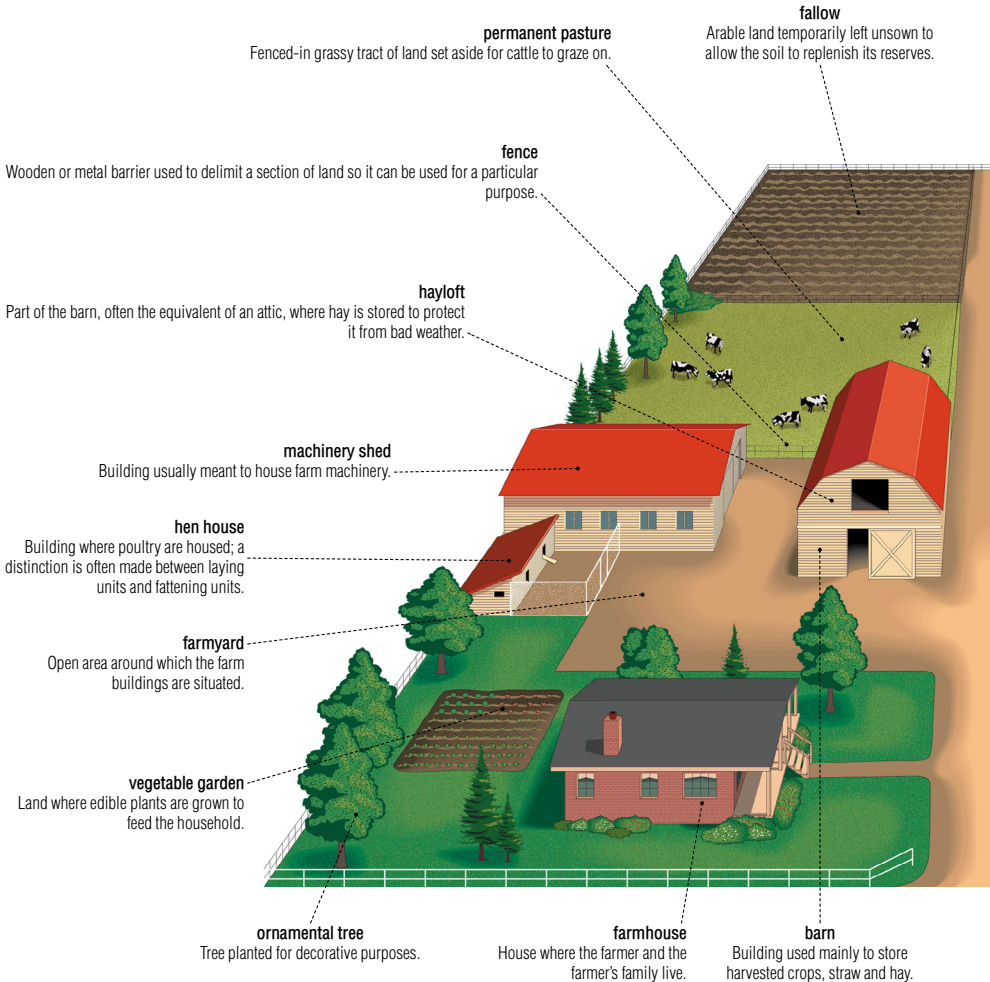

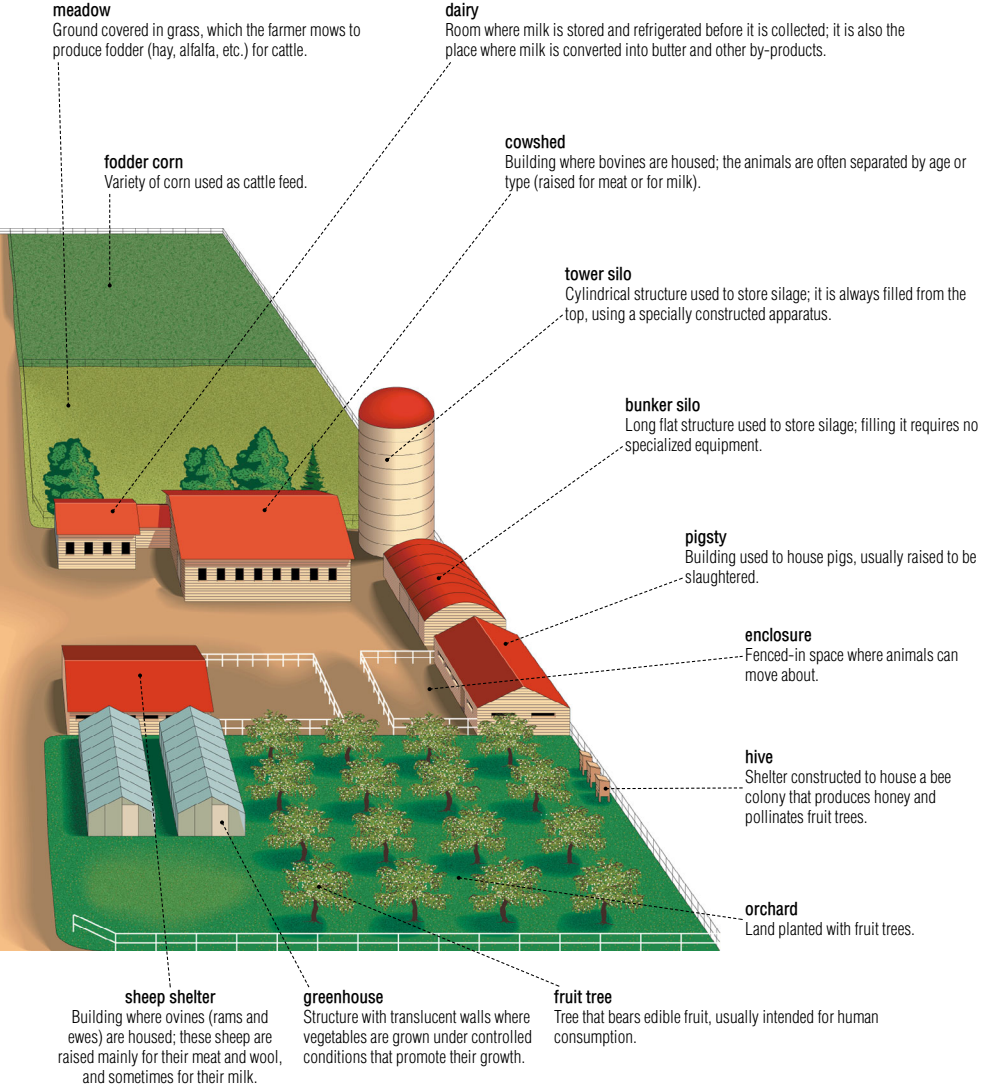

supermarket

A large self-service store that sells food and various everyday household goods; the part accessible to shoppers is surrounded by service areas reserved for storage and for preparing and preserving merchandise.

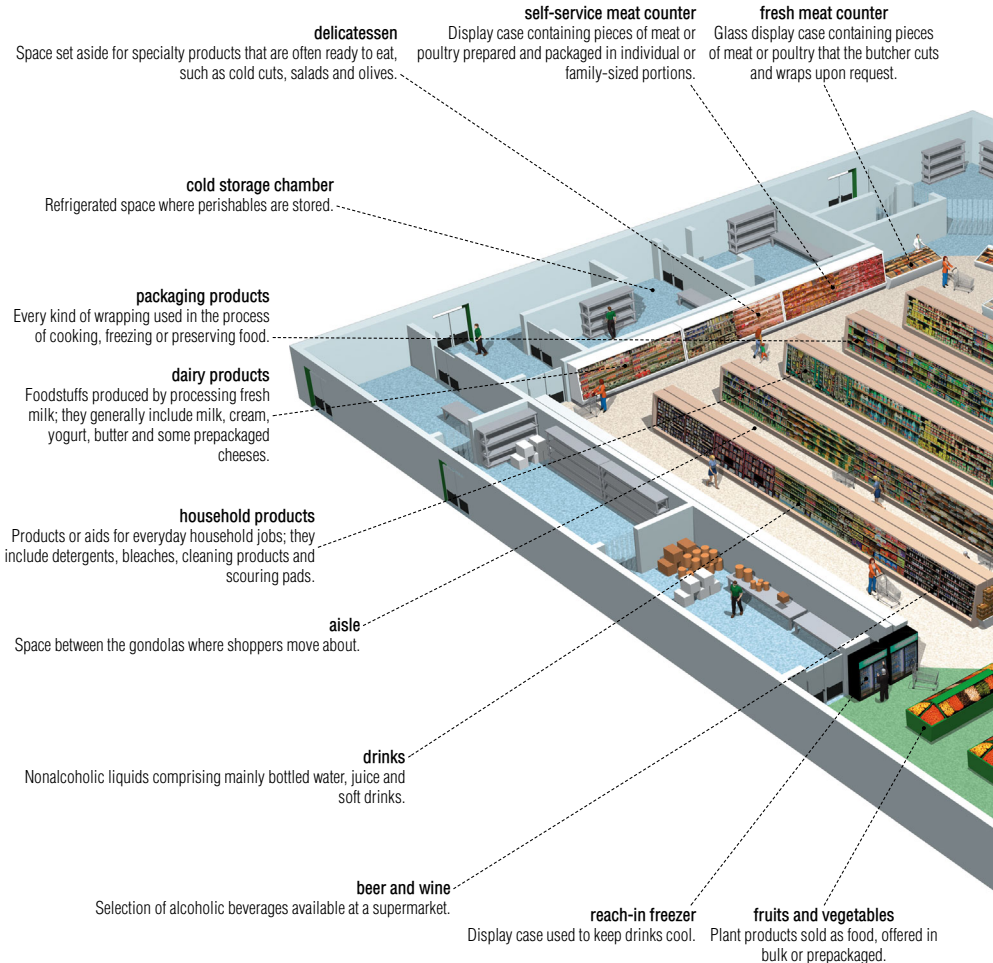

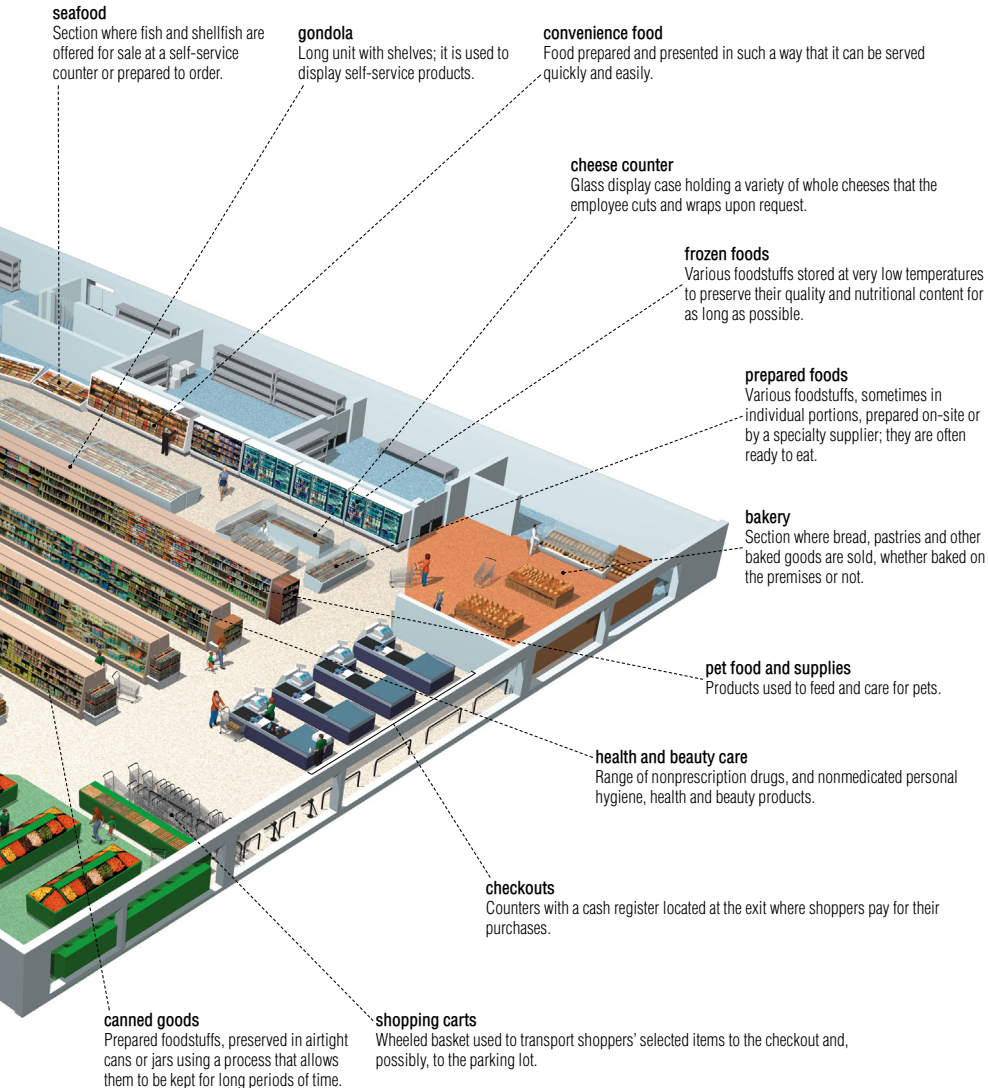

seafood

Section where fish and shellfish are offered for sale at a self-service counter or prepared to order.

gondola

Long unit with shelves; it is used to display self-service products.

convenience food

Food prepared and presented in such a way that it can be served quickly and easily.

cheese counter

Glass display case holding a variety of whole cheeses that the employee cuts and wraps upon request.

frozen foods

Various foodstuffs stored at very low temperatures to preserve their quality and nutritional content for as long as possible.

prepared foods

Various foodstuffs, sometimes in individual portions, prepared on-site or by a specialty supplier; they are often ready to eat.

bakery

Section where bread, pastries and other baked goods are sold, whether baked on the premises or not.

pet food and supplies

Products used to feed and care for pets.

health and beauty care

Range of nonprescription drugs, and nonmedicated personal hygiene, health and beauty products.

checkouts

Counters with a cash register located at the exit where shoppers pay for their purchases.

canned goods

Prepared foodstuffs, preserved in airtight cans or jars using a process that allows them to be kept for long periods of time.

shopping carts

Wheeled basket used to transport shoppers' selected items to the checkout and, possibly, to the parking lot.

restaurant

Business establishment where people pay to eat a meal prepared on the premises and served at their table; a restaurant's quality and prices vary depending on the menu.

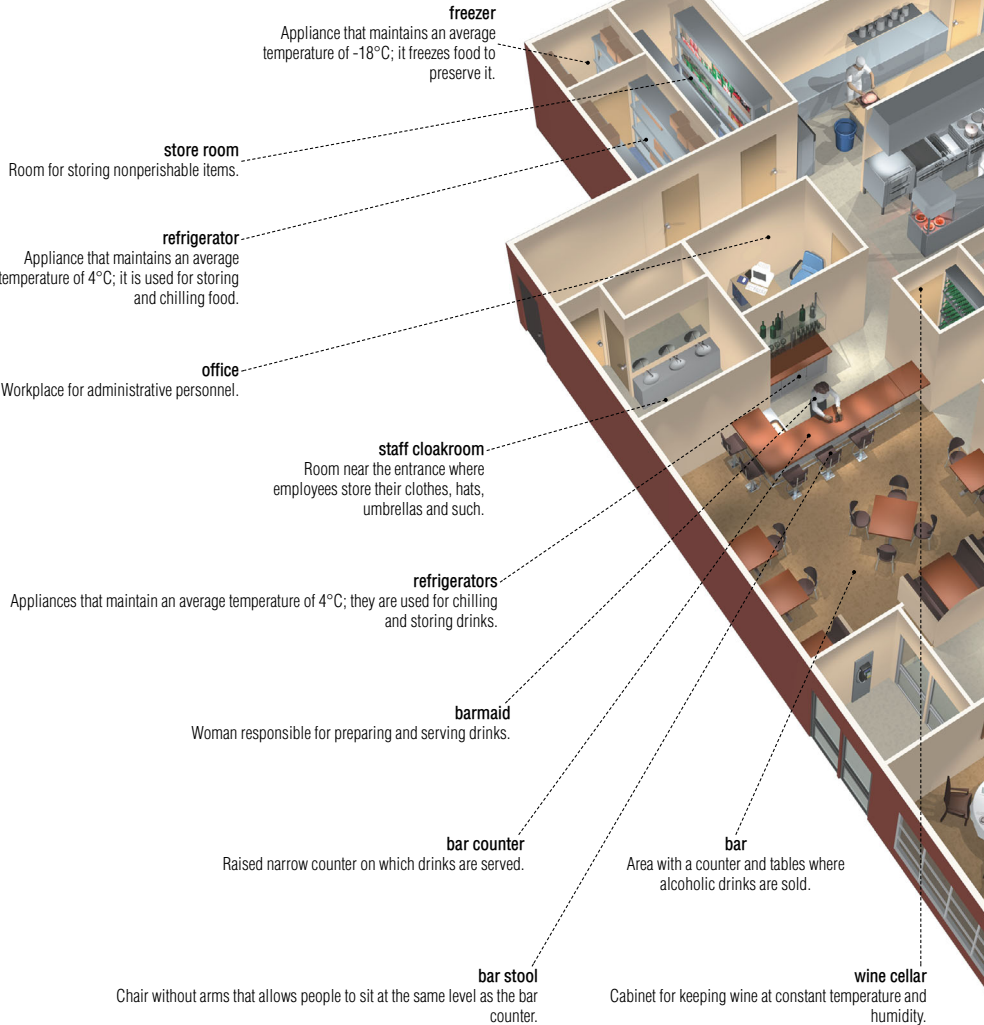

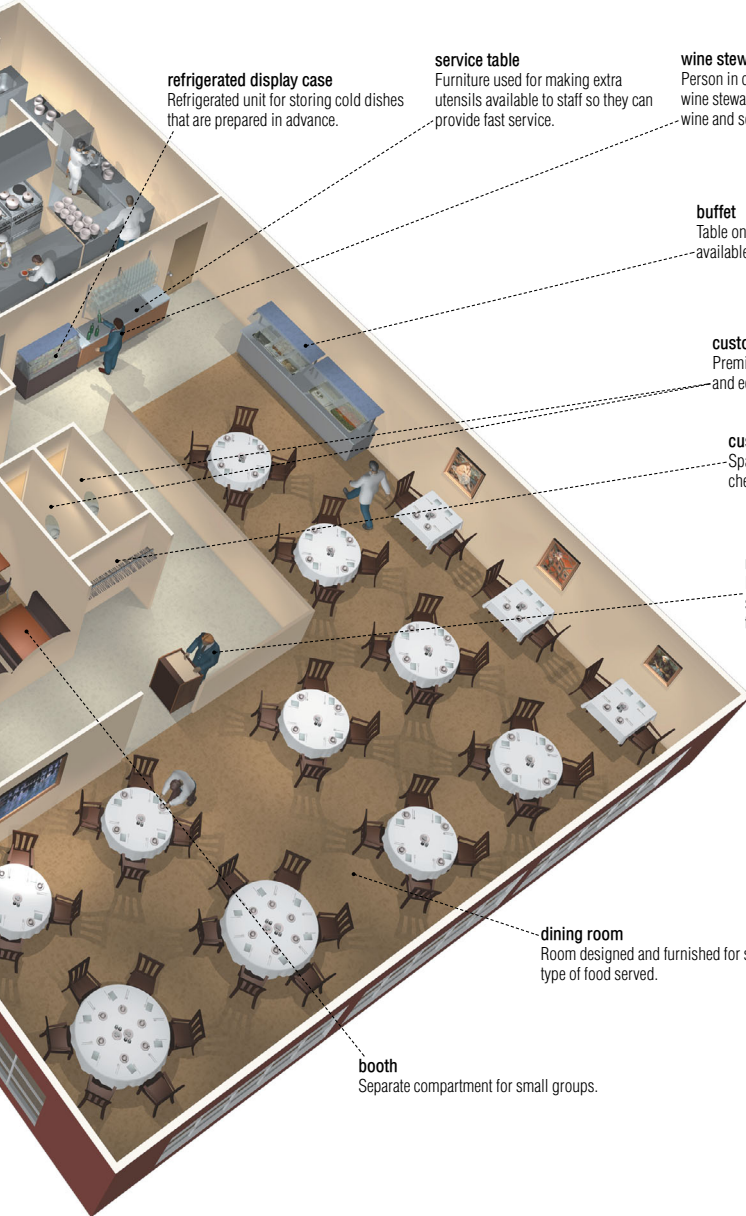

refrigerated display case
Refrigerated unit for storing cold dishes that are prepared in advance.

service table
Furniture used for making extra utensils available to staff so they can provide fast service.

wine steward
Person in charge of the wine cellar; the wine steward helps customers choose a wine and sometimes serves it as well.

buffet
Table on which hot and cold dishes are made available so that people can serve themselves.

customers' toilets
Premises designed to satisfy basic functions and equipped with toilets and sinks.

customers' cloakroom
Space near the entrance where customers check their coats, hats, umbrellas and such.

mâitre d'hôtel
Person who manages the reservation system, greets customers and supervises the dining room staff.

dining room
Room designed and furnished for serving meals; its decor often reflects the type of food served.

booth
Separate compartment for small groups.

kitchen

Room where meals are prepared under the direction of a chef who is assisted by a kitchen staff.

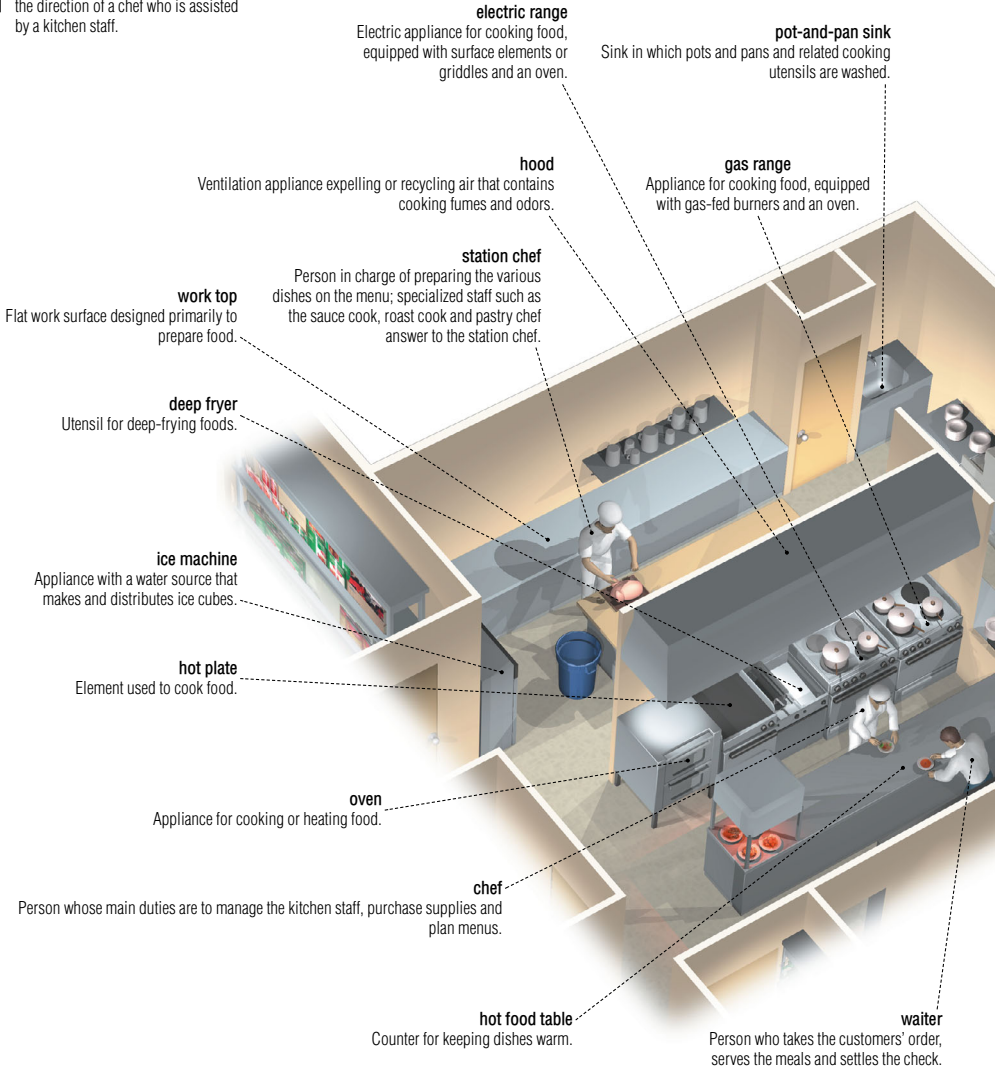

electric range

Electric appliance for cooking food, equipped with surface elements or griddles and an oven.

pot-and-pan sink

Sink in which pots and pans and related cooking utensils are washed.

hood

Ventilation appliance expelling or recycling air that contains cooking fumes and odors.

gas range

Appliance for cooking food, equipped with gas-fed burners and an oven.

station chef

Person in charge of preparing the various dishes on the menu; specialized staff such as the sauce cook, roast cook and pastry chef answer to the station chef.

work top

Flat work surface designed primarily to prepare food.

deep fryer

Utensil for deep-frying foods.

ice machine

Appliance with a water source that makes and distributes ice cubes.

hot plate

Element used to cook food.

oven

Appliance for cooking or heating food.

chef

Person whose main duties are to manage the kitchen staff, purchase supplies and plan menus.

hot food table

Counter for keeping dishes warm.

waiter

Person who takes the customers' order, serves the meals and settles the check.

menu
Itemized list of dishes served in a restaurant.

dishwasher

Appliance designed to automatically wash and dry dishes.

dishwasher

Person in charge of washing cooking utensils and dishes.

prerinse sink

Sink in which dishes are rinsed before being placed in the dishwasher.

dirty dish table

back waiter

Person who clears the tables during and after service.

clean dish table

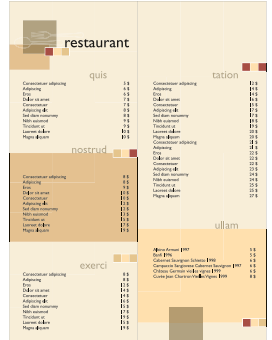

wine list
Itemized list of wines and spirits served in a restaurant.

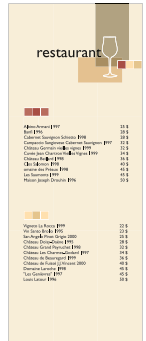

check
Chit indicating the total amount spent by the customer.

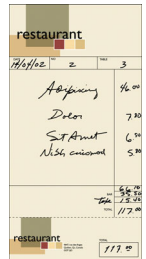

mushrooms

Vegetable that grows in damp cool places; its edible varieties are served as condiments or as an ingredient in a variety of foods.

**royal agaric**

Equally flavorful raw or cooked, it has been famous since ancient times; it is not to be confused with the poisonous fly agaric, which it resembles.

**delicious lactarius**

Secretes an orange milk when broken open; it is used primarily in spicy sauces, especially in Spain and the south of France.

**enoki mushroom**

Long-stemmed, soft-fleshed resistant mushroom very popular in Asia; it is eaten raw, in salads, or cooked, in soups and Oriental dishes.

**green russula**

Its white brittle flesh has an aroma of hazelnut; it can be eaten raw or cooked, preferably grilled.

**morel**

The darker the specimen, the more flavorful its thin fragrant flesh; it should be thoroughly cooked to eliminate toxic substances.

**edible boletus**

Squat, it can grow up to 10 in in height and diameter; it is usually cooked in oil, braised or served in an omelette.

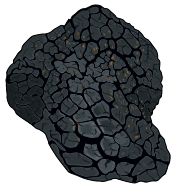
**truffle**

Underground mushroom hard to find and perceived as a luxury food; it is usually associated with game and poultry.

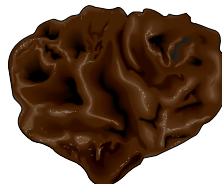
**wood ear**

Its tasteless gelatinous flesh is popular in Asia; it is usually eaten in soups or with vegetables.

**oyster mushroom**

Grows on trees or on dead wood; its soft white flesh is a valued ingredient in sauces, where it can substitute for the cultivated mushroom.

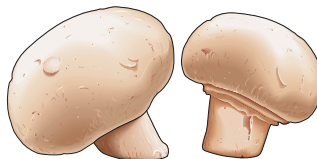
**cultivated mushroom**

The most widely cultivated and consumed mushroom; it is eaten raw, in salads or with dips, or cooked, primarily in sauces and on pizza.

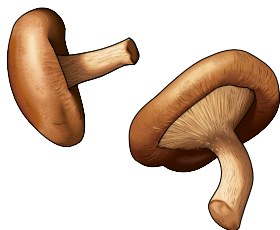
**shiitake mushroom**

The equivalent of the cultivated mushroom in Japan, where it is widely grown for use in Oriental dishes and sauces and for its therapeutic value.

**chanterelle**

Pleasantly fragrant and valued by gourmets, especially those in Europe; it is served most often with meat or omelettes.

seaweed

Usually aquatic vegetables used in cooking or as dietary supplements; they are primarily produced and eaten by the Japanese.

**aramé**

Milder and less crunchy than hijiki, it is used mainly in salads and soups or served fried as a side vegetable.

**wakame**

Popular with the Japanese, it is rich in calcium and has a delicate texture and flavor; among its many uses, it is often served with legume dishes.

**spirulina**

Microscopic freshwater alga, rich in nutrients (protein, iron, magnesium); it is used mainly as a dietary supplement.

**Irish moss**

Plentiful in the North Atlantic, it can only be eaten cooked; also produces carrageen, a substance used to thicken certain dishes.

**agar-agar**

Translucent strips derived from red algae, which is melted to produce a jelly that can replace gelatin in numerous recipes.

**hijiki**

These dried twigs expand when soaked, resembling black, somewhat crunchy noodles; they are often served as a vegetable.

**kombu**

Eaten since ancient times, it is sold in large blackish strips; it is used primarily as an ingredient in broth or to make a kind of tea.

**sea lettuce**

Resembles lettuce leaves in taste and appearance; its soft leaves are eaten raw in salads or cooked in soups.

**nori**

Purplish alga that turns black when dried; usually sold in thin dried sheets, it is used mainly to make sushi.

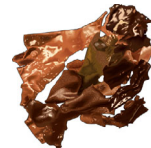
**dulse**

Iron-rich, it has long been eaten by people living along Europe's coasts; it enhances soups and salads with its soft texture and strong flavor.

Plants used as foodstuffs; a simple way to classify vegetables is to group them according to their edible part. The sweet fruit category of plants constitutes another food category (fruits).

bulb vegetables

The main edible part of these vegetables is their bulb, the underground structure where the plant's nutrient reserves are stored.



leek

The white part is the most popular, but the green part adds flavor to puréed soups and stews; it is often combined with potatoes in a cold soup called vichyssoise.



red onion

The sweetest of the onions, it is often eaten raw, in salads or sandwiches.

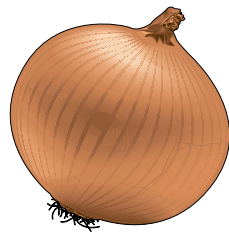

yellow onion

The most common onion, widely used as a flavoring ingredient, either raw or cooked; it is also the essential ingredient in onion soup.

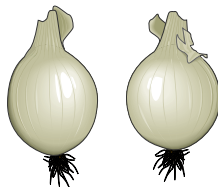

pickling onion

Small white onion pickled before fully ripe; it is primarily used to make pickles or as an ingredient in stews such as boeuf bourguignon.

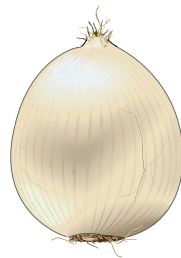

white onion

Mild and sweet, this onion is widely used as a flavoring ingredient; it is often eaten raw or deep-fried in rings.

**shallot**

It has a more subtle flavor than the onion or the chive; it is eaten raw or cooked and often used as a flavoring ingredient in sauces.

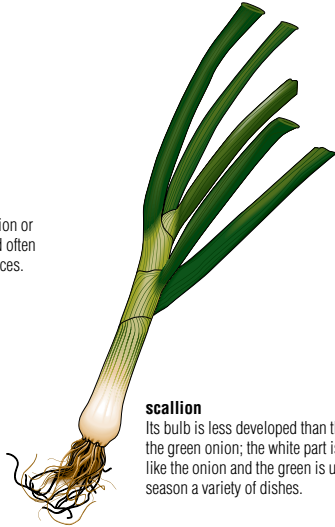
**scallion**

Its bulb is less developed than that of the green onion; the white part is used like the onion and the green is used to season a variety of dishes.

**green onion**

Mild onion picked before fully ripe; it is usually sold with the stem, in bunches. It is often eaten raw in salads or cooked in sautéed dishes.

**water chestnut**

The aquatic bulb of a Chinese plant; its white crunchy flesh is an important ingredient in many Asian dishes.

**garlic**

The bulb is composed of bulblets called cloves; the germ at its center can make garlic difficult to digest.

**chive**

Smallest member of the onion family; its stem is used primarily to season various hot and cold dishes.

tuber vegetables

Tubers that are eaten like vegetables; they consist of underground growths containing the plant's nutrient reserves.

**crozne**

Native to Asia, where it is very popular although little known elsewhere; it has a slightly sweet flavor and is used and prepared like the potato.

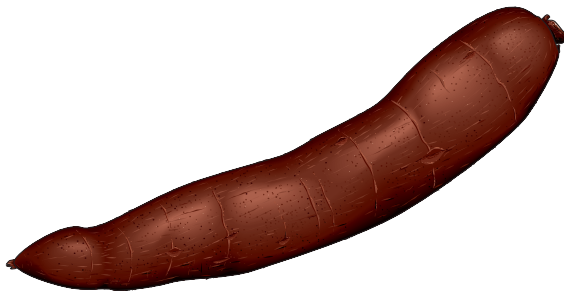
**cassava**

The sweet variety is eaten like the potato; the bitter one is used to make tapioca.

**taro**

Its starchy, sweet flesh is a staple in several tropical countries; eaten raw, preferably very hot and prepared like the potato.

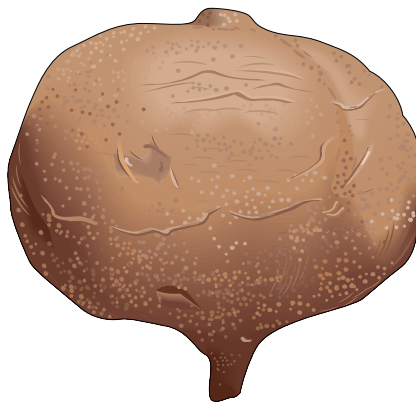
**jicama**

Its flesh is sweet, crunchy and juicy; it is eaten raw in salads, as an hors d'oeuvre or with dips; it adds a crunchy element to cooked dishes.

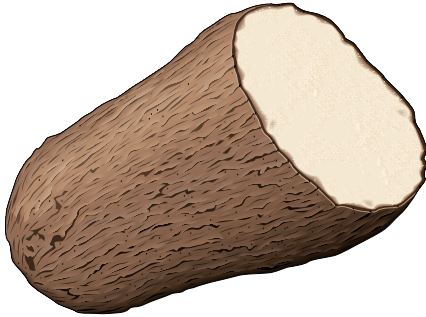
**yam**

A staple food in many countries, especially in South America and the West Indies, where it is eaten cooked, prepared like the potato.

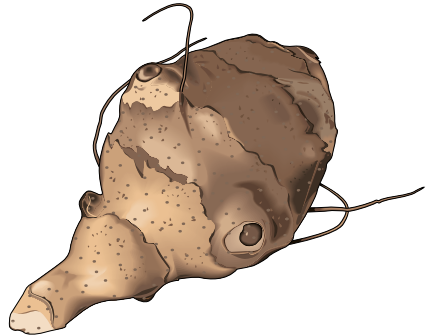
**Jerusalem artichoke**

Eaten raw, cooked or marinated; it has sweet, crunchy, juicy flesh.

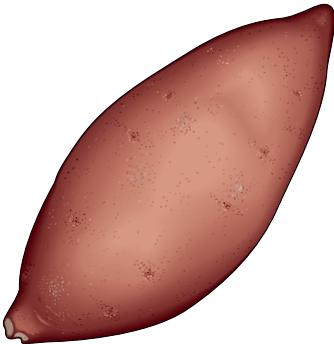
**sweet potato**

Sweeter than the potato and not of the same family; a staple of Creole cooking.

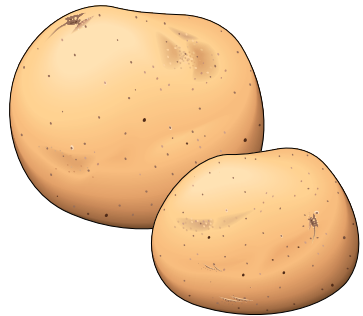
**potato**

The best-known tuber; eaten especially as a vegetable side dish, either steamed, deep-fried or mashed.

stalk vegetables

Edible plants whose stems are consumed like vegetables; the leaves of some varieties are also edible.

asparagus

Often thought of as a luxury, it is picked before fully ripe; whether served hot or cold, it is always cooked.

**tip**

Top end of the spear; the most valued part of the asparagus for cooking.

spear

Young asparagus shoot that constitutes the plant's edible part and grows out of an underground stem; its hard end is usually removed before cooking.

bundle

A number of asparagus spears tied together; asparagus is usually sold in this way.

Swiss chard

A member of the beet family, grown for its ribs, prepared like celery or asparagus, and for its leaves, often said to resemble spinach.

leaf
Thin flattened part of the chard that grows out of the rib; it is eaten cooked or raw, mainly in salads.

**rib**

The chard's long fleshy petiole, whitish or red depending on the variety, is both soft and crunchy.

fiddlehead fern

When coiled, this young shoot is ready to eat; it is especially popular in salads, pasta dishes and omelettes.

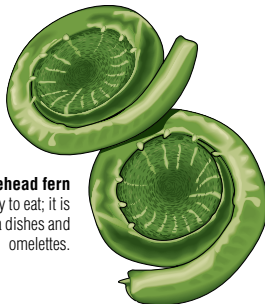

fennel

Mainly associated with Italian cooking; the bulb is eaten as a vegetable while the leaves and seeds are used to season a variety of dishes.

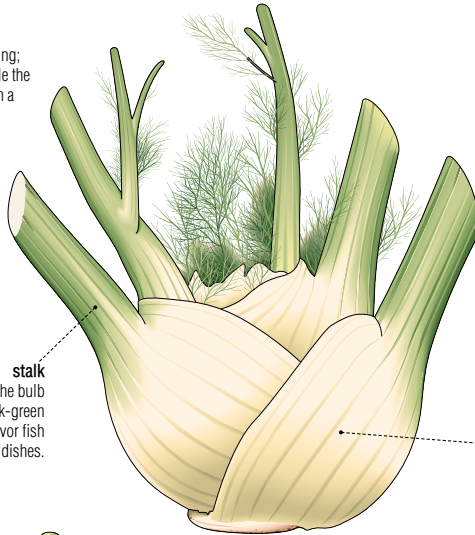
**stalk**

Part of the fennel growing out of the bulb and bearing small feathery dark-green leaves; it is traditionally used to flavor fish dishes.

bulb

Fleshy edible part of the fennel, composed of the overlapping enlarged parts at the base of the stems.

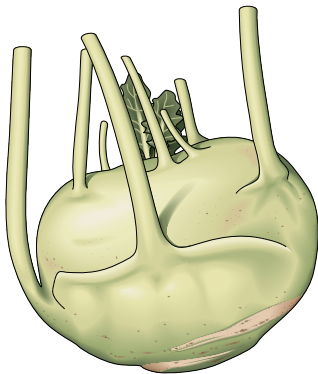
**kohlrabi**

Very popular in Central and Eastern Europe, where its bulbous stem is eaten raw or cooked like turnip; its cabbage-flavored leaves can also be eaten.

**bamboo shoot**

Very popular in Asia, this plant can only be eaten once cooked; it is an essential ingredient in sukiyaki, a typical Japanese dish.

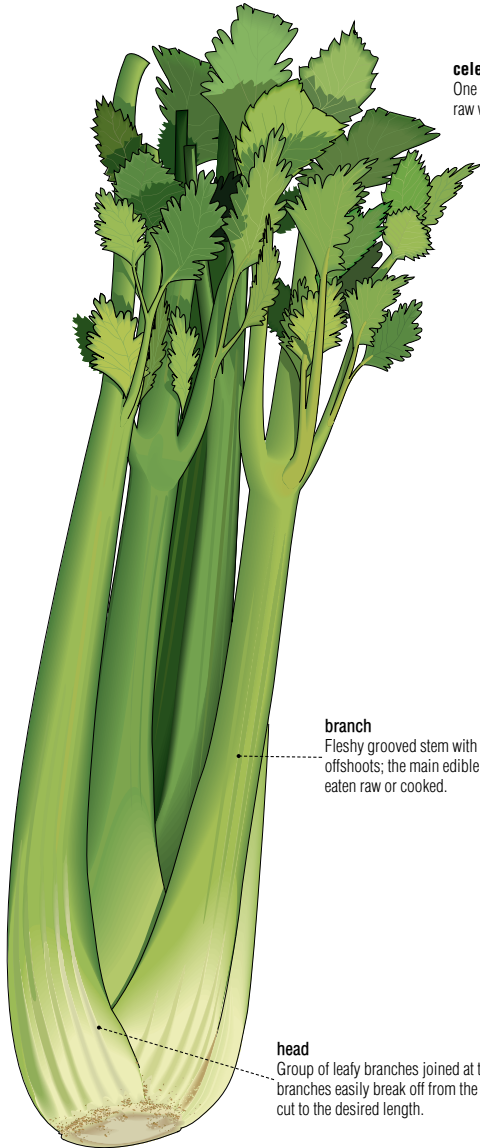
**celery**

One of the best-known and most popular stalk vegetables, it is often served raw with dips; the leaves and seeds are used to season a variety of dishes.

branch

Fleshy grooved stem with leaf-bearing offshoots; the main edible part of the celery is eaten raw or cooked.

head

Group of leafy branches joined at the base; the branches easily break off from the base and can then be cut to the desired length.

cardoon

A member of the artichoke family and little known in North America, its flavor is similar to that of celery; it is prepared like asparagus and served hot or cold.



vegetables

leaf vegetables

Leaves of edible plants consumed as vegetables.

**leaf lettuce**

Lettuce having soft wavy leaves with curly edges; like most types of lettuce, it is usually eaten raw, in salads or sandwiches.

**romaine lettuce**

Lettuce with firm crisp leaves used especially to make Caesar salad.

**celtuce**

The result of crossing lettuce and celery, it is mainly known in the Orient; the stems are eaten raw or cooked.

**escarole**

Its leaves are less bitter than those of the curled endive, to which it is related; it is usually eaten raw, in salads.

**butterhead lettuce**

Formed in a loosely compacted ball, its large soft leaves break off easily; Boston lettuce is a well-known variety of this species.

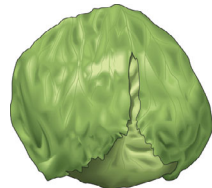
**iceberg lettuce**

The most widely sold lettuce in North America, it was initially covered with ice during transport, hence its name.

**radicchio**

Red endive native to northern Italy and having a somewhat bitter taste; it is often served with other types of lettuce.

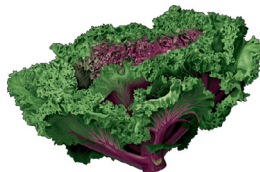
**ornamental kale**

Related to the curled kale; its differently colored leaves are added to salads, soups and rice, or used to garnish serving platters.

**sea kale**

Widely used in Europe, its leaves and wide fleshy stems are prepared like asparagus.

**collards**

It has thick, strongly flavored leaves and tough central ribs; it is eaten like spinach, either raw or cooked.

**curled kale**

Its very curly, stringy tough leaves have a strong flavor; it is almost always eaten cooked.

**Brussels sprouts**

The smallest member of the cabbage family is only eaten cooked and whole as a vegetable side dish.

**red cabbage**

Milder-tasting than other cabbages, it is usually eaten raw and finely chopped in salads.

**white cabbage**

After fermentation, it is used to make sauerkraut; it is also used as an ingredient in stews.

**savoy cabbage**

Cabbage with somewhat flexible leaves, making it well suited to preparing cabbage rolls.

**green cabbage**

When finely chopped, it is the main ingredient in coleslaw; it is also added to soups and stews.

**nettle**

When cooked or dried, the leaves lose their sting; it has a somewhat spicy flavor and can be prepared more or less like spinach.

**watercress**

Tender and juicy, it is mostly eaten raw, in salads; the delicate leaves have a slight mustardlike flavor.

**dandelion**

The leaves of this common plant are excellent in salads; when cooked, they can be prepared like spinach.

**purslane**

Both the stems and the tender fleshy leaves are eaten; it has a slightly acidic, spicy flavor.

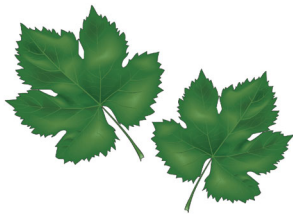
**grape leaf**

Associated with Mediterranean cooking, it is used to prepare dolmades (stuffed vine leaves) and as a garnish for fruit and salad platters.

**pe-tsai**

A crunchy refreshing Chinese cabbage, mostly eaten cooked.

**pak-choi**

The stems of this Chinese cabbage are juicy and crunchy; it is served in soups, with rice and in many Chinese dishes.

**corn salad**

Also called lamb's lettuce; its soft, mild-tasting leaves are primarily eaten raw, in salads.

**arugula**

Especially popular in southern France and Italy; whether raw or cooked, it should be used in moderation because of its strong flavor.

**garden sorrel**

Its slightly lemon-flavored leaves are traditionally served with fish and veal; it is also used in a puréed soup that is a classic in a number of European countries.

**spinach**

The vegetable used to make dishes à la Florentine. It is also eaten raw, in salads, and cooked, as a side dish or a stuffing ingredient.

**curled endive**

The very frilly, somewhat bitter leaves are primarily eaten raw, in salads.

**garden cress**

Picked while very young and sold in bunches; its tiny leaves add a hint of spice especially to salads, sandwiches and sauces.

**Belgian endive**

Its crunchy, slightly bitter leaves are much in demand for salads (used raw) or for such classic recipes as endive and ham au gratin.

inflorescent vegetables

The flowers or flower buds of edible plants eaten as vegetables.

**Gai-lohn**

Also called Chinese broccoli, its delicately flavored leaves and stems can be eaten raw or cooked, prepared in the same manner as broccoli.

**broccoli rabe**

Its slightly bitter stems, leaves and flowers can all be eaten, prepared like broccoli.

**artichoke**

Especially valued for its soft fleshy heart, it is often served with a dipping sauce; the leaves surrounding the heart can also be eaten.

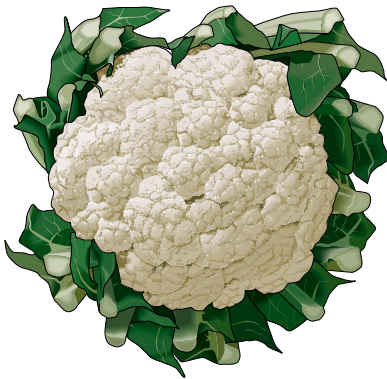
**cauliflower**

The head, composed of immature buds, is either white or purple; it is eaten raw or cooked.

**broccoli**

Native to Italy, it is often green and occasionally white or purple; it is chosen primarily for its flower buds but the stem and leaves are also eaten.

fruit vegetables

Fruits of edible plants consumed as vegetables.

**hot pepper**

Cutting it or removing the seeds moderates its spicy burning taste.

**okra**

Vegetable containing a substance used to thicken soups and ragouts, it is used in many Creole dishes.

**tomatillo**

Picked when green, this berry is used to make sauces and is an essential ingredient in many Mexican dishes.

**olive**

Inedible when raw, the olive is treated to reduce its bitter taste, then cured in brine or sometimes in oil.

**green sweet pepper**

Mild pepper picked before fully ripe, it is used in many typical Mexican and Portuguese dishes.

**red sweet pepper**

Mild pepper picked when ripe, it is very sweet and has a higher vitamin C content than the green sweet pepper.

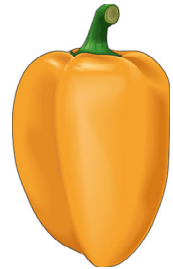
**yellow sweet pepper**

Mild pepper picked when ripe, it is strongly scented and has a sweet taste; it is often used in salads.

**avocado**

Fruit of the avocado tree; its smooth greenish flesh is eaten raw, in salads or mashed.

**currant tomato**

Very flavorful tomato characterized by its sweetness and long shelf life.

**tomato**

Native to Central America, this fruit is essential to Italian, Provençal, Greek and Spanish cooking.

**cucumber**

Related to squash and melons, it bears seeds and is usually eaten raw.

**gherkin**

Picked when not yet ripe, it is often pickled in vinegar and eaten as a condiment; it is also served raw in salads.

**wax gourd**

Its firm flavorful flesh is often used in puréed soups or spicy dishes.

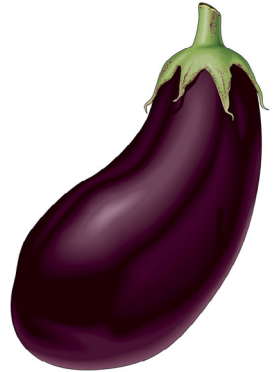
**eggplant**

Yellowish and spongy-fleshed vegetable that is sometimes sweated with salt to alleviate its bitter taste.

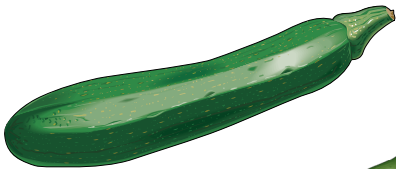
**zucchini**

Small white-fleshed squash picked before fully ripe; it is an essential ingredient in ratatouille.

**seedless cucumber**

European variety grown exclusively in greenhouses without fertilization.

**bitter melon**

Too bitter to be eaten raw, it is an ingredient in various kinds of Asian cooking, such as soups or steamed dishes.

summer squash

Picked when ripe, the seeds are removed and the flesh eaten raw or cooked; it bears edible flowers.





pattypan squash

When very ripe the flesh turns hard and white; its firm flesh has a flavor similar to the artichoke.



crookneck squash

The soft edible rind is covered in small ridges; best if picked very early, it can be eaten raw or cooked.



straightneck squash

The result of genetically altering the crookneck squash to eliminate the thin crooked neck; it is eaten raw or cooked.

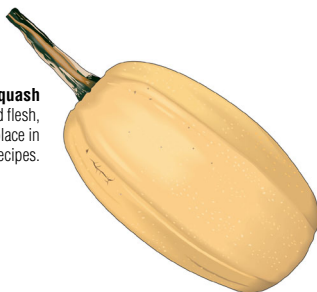

spaghetti squash

Derives its name from its cooked flesh, resembling spaghetti, which it can replace in most recipes.



acorn squash

Its smooth hard skin turns orange when fully ripe; the delicate, slightly fibrous flesh tastes of pepper and hazelnuts.



pumpkin

Used primarily in North America, it can be recognized by its hard fibrous pedicel; its flesh is widely used in soups and desserts and its edible seeds are dried.



autumn squash

The rind can be yellow, orange or green; often confused with the pumpkin, it can be recognized by its pedicel, which is soft and enlarged where it attaches to the vegetable.



chayote

This squash, grown mainly in tropical countries, is used in Creole cooking; the central stone can be eaten once cooked.

root vegetables

The fleshy roots of edible plants consumed as vegetables.

**black radish**

Popular in Eastern Europe, although less juicy than the red radish; it can be cooked or sweated with salt to alleviate its bitter taste.

**radish**

Juicy and crunchy, it is eaten raw, as an hors d'oeuvre or in salads; it is also popular served cooked or pickled, especially in Asia.

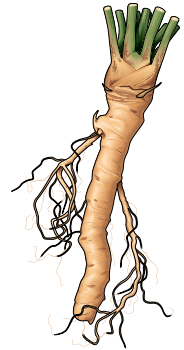
**horseradish**

Often used as a flavoring ingredient, especially in sauces; its strong flavor becomes milder when mixed with cream or mayonnaise.

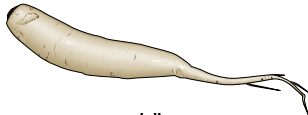
**daikon**

Its somewhat mild-tasting flesh, leaves and sprouted seeds are prepared in various ways; in Japan, it is served with sashimi.

**carrot**

Eaten in a variety of ways: plain, in salads, in deserts, as a vegetable side dish or a juice.

**salsify**

Its sweet mild flavor is often said to resemble the oyster's; its young leaves are also edible.

**parsnip**

The yellowish flesh of this little-known vegetable has a slightly nutty taste and a texture similar to the turnip; it can be eaten raw or cooked.

**black salsify**

Closely related to salsify, its cream-colored flesh is less stringy and more flavorful; it is an ingredient in dishes such as soups and ragouts.

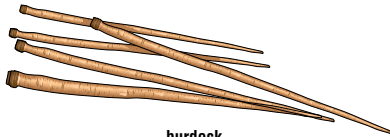
**burdock**

Root of a plant harvested before the floral stem develops; it is used as a vegetable or as a flavoring ingredient.

**turnip**

Often confused with the rutabaga, this white-fleshed vegetable is eaten raw or cooked and prepared like carrots.

**rutabaga**

Larger and stronger-tasting than the turnip, it can be recognized by its usually yellow flesh and by the bump on its top.

**beet**

Its usually red flesh contains a juice that stains readily; it is eaten raw, pickled or cooked, most famously in borscht, a hearty soup from Eastern Europe.

**malanga**

A staple in the West Indies, where it is grated and used to make fried doughnuts called *acas*; its strong taste hints of hazelnuts.

**celeriac**

A slightly spicy kind of celery; the raw vegetable, combined with mustard mayonnaise, becomes the classic celeriac remoulade.

legumes

The main edible part of these pod-shaped fruits is their seeds, consumed fresh, dried or sprouted; if dried, they often require soaking before they can be cooked.

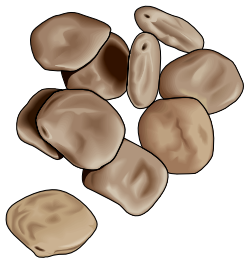
**lupine**

Protein-rich seed, prepared and served plain or sprinkled with lemon juice.

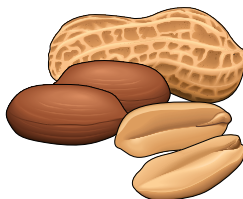
**peanut**

Often served as a snack, it is also made into a butter and a vegetable oil and, in some countries, into a spicy sauce served with a variety of dishes.

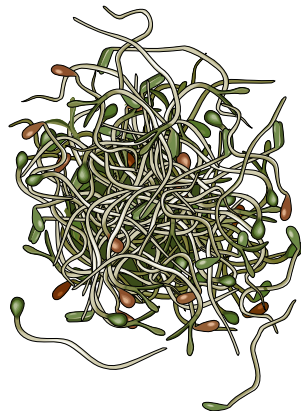
**alfalfa**

The sprouted seeds are added raw to sandwiches or used in various cooked dishes.

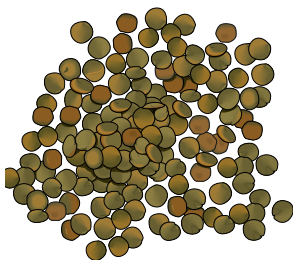
**lentils**

A main ingredient of hearty soups, they can also be puréed and made into croquettes; in India, they are often paired with rice.

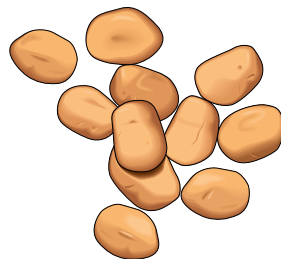
**broad beans**

Starchy and strong-tasting, they are typically puréed; they are also eaten whole and added to soups and stews.

peas

The rounded seeds are called "green peas" when they are fresh and "dried peas" when they are dried.

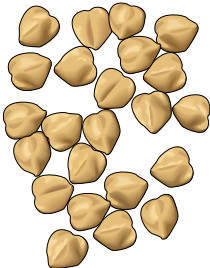
**chick peas**

Basic ingredient of hummus and falafel and found in couscous; they are also used to make various southern French dishes such as estouffade.

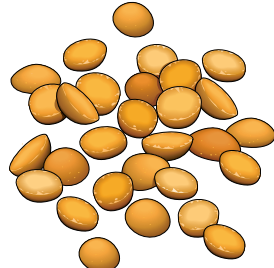
**split peas**

These pea seeds, dried and split in two, are generally puréed and used in various kinds of soups.

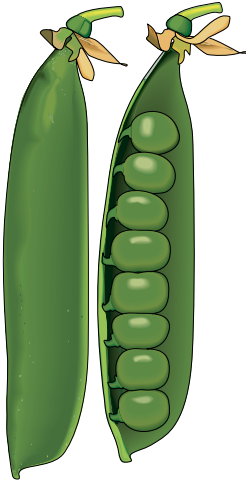
**green peas**

Delicious freshly picked, they are also available frozen or canned; a component of mixed vegetables and of dishes labeled "à la jardinière".

**sweet peas**

Eaten freshly picked with the sweet and crunchy pod, hence their name; they are especially popular in Chinese dishes.

legumes

dolichos beans

Fruit of a member of the bean family; the seeds are somewhat elongated and ovoid.

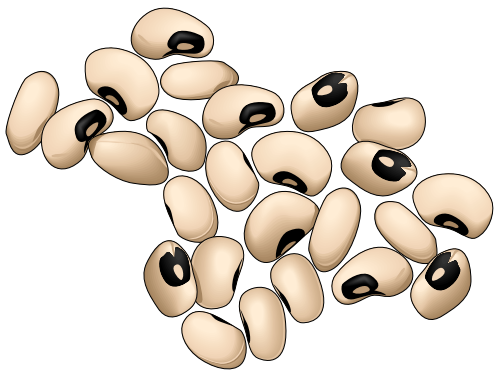
**black-eyed pea**

This flavorful seed has a black spot that resembles an eye, hence its name; it is typical especially of southern American cooking.

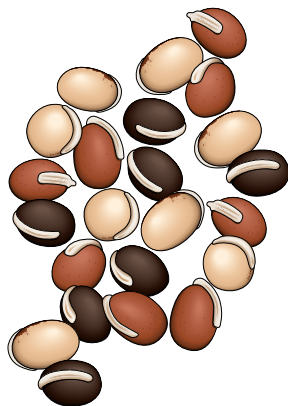
**lablab bean**

Characterized by a white ridge, it can be sprouted or ground into flour.

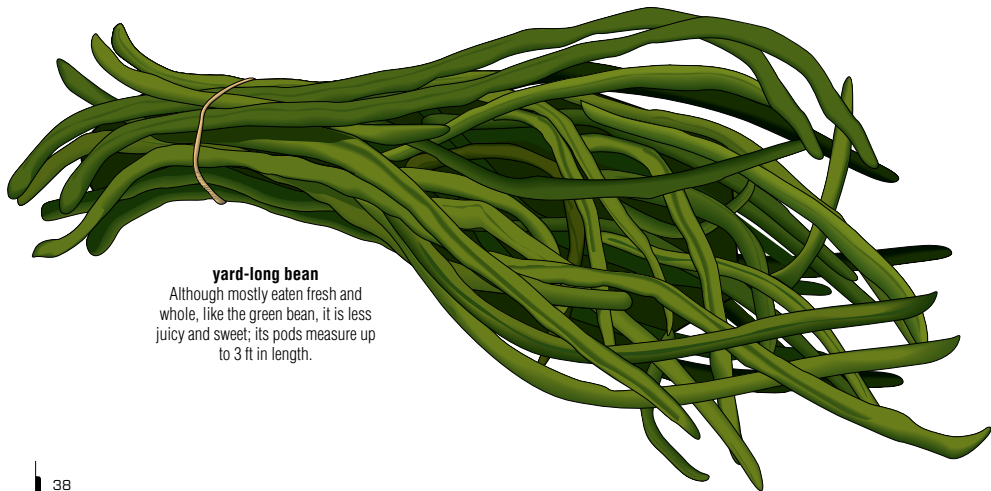
**yard-long bean**

Although mostly eaten fresh and whole, like the green bean, it is less juicy and sweet; its pods measure up to 3 ft in length.

beans

Fruits of plants native to Central and South America, the seeds are oval or kidney-shaped; before they are fully ripe, the pods are often edible.

green bean

The young green pod is usually served as a vegetable side dish, sometimes with sauce or butter.

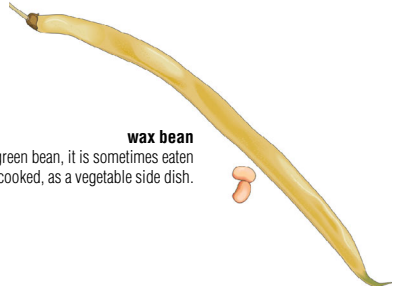
**wax bean**

Somewhat juicier than the green bean, it is sometimes eaten raw but mostly cooked, as a vegetable side dish.

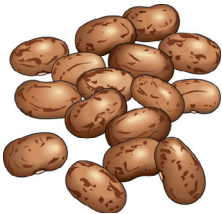
**roman bean**

A staple of Italian cooking, it resembles the pinto bean, although often larger and darker; it absorbs the flavor of the foods it is cooked with.

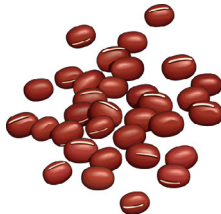
**adzuki bean**

Has a delicate flavor and is often served with rice; in Asian countries, the paste made from these beans can replace tomato paste.

**scarlet runner bean**

The seeds are eaten fresh or dried, in which case they are prepared like the red kidney bean; a favorite accompaniment to onions, tomatoes and tuna.

**mung bean**

In Asia they are either puréed or ground into flour; in the West they are more commonly eaten sprouted, especially in chop suey.

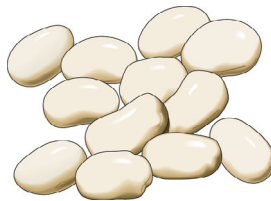
**Lima bean**

Has a mild flavor and a starchy texture and is generally green- or cream-colored; when puréed, it can replace the potato.

**pinto bean**

When cooked, their spots disappear and they turn pink; because of their creamy texture, they are mostly used to make purées.

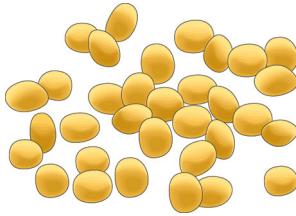
**soybeans**

Produces a kind of milk used mainly to make tofu and also a vegetable oil; when fermented, it is the main ingredient in soy sauce.

**flageolet**

Thin flat and less starchy than most other legumes, this bean is a favorite in France, where it is traditionally served with leg of lamb.

**soybean sprouts**

After sprouting for a few days they are ready to be eaten, either raw or lightly cooked; they are characteristic of Chinese cooking.

**red kidney bean**

One of the best-known beans, it is used to make the Mexican dish called chili con carne; it retains its shape when cooked so is often canned.

**black gram**

A favorite in Asia, where it is used to make a popular black sauce; in India, it is mixed with rice to make pancakes and a spicy purée.

**black bean**

Available mainly in Central and North America, it is a staple of Mexican cooking.

Usually sweet vegetables, primarily consumed at breakfast, as a snack or for dessert, and used extensively in pastry and candy making.

stone fruits

Fruits whose somewhat juicy flesh surrounds a hard, usually inedible stone.

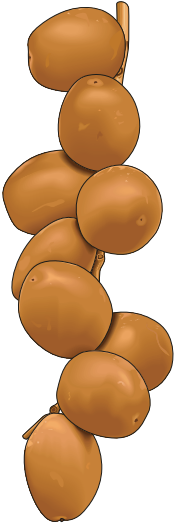
**date**

Has a high sugar content and is often sold dried; in North America, it is primarily associated with baked goods, such as squares, muffins and cakes.

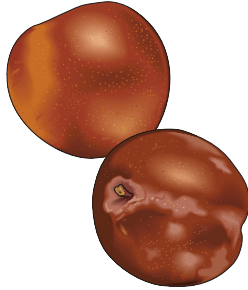
**plum**

Of various colors and sizes, it is excellent either raw or cooked and is used especially to make chutney; the dried plum is called a prune.

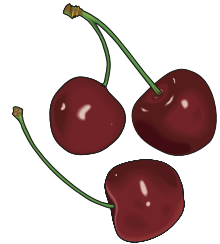
**cherry**

An essential ingredient in Black Forest cake and, candied, in fruitcake; when artificially colored and flavored, it is used as a cocktail garnish.

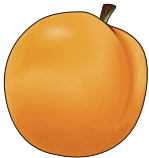
**apricot**

Often eaten dried or candied, its orange flesh can be mushy if picked before fully ripe; the kernel inside the stone contains a toxic substance.

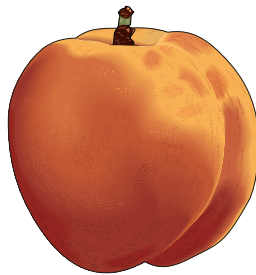
**peach**

A velvety skin covers its juicy fragrant flesh; it is especially enjoyed plain, in juice and in various desserts, such as the classic peach melba.

**nectarine**

Differentiated from the peach by its smooth, more colorful skin and by its more flavorful flesh; like the peach, it is eaten raw or used in certain desserts.

fruits

berries

Small fleshy fruits containing one or several usually edible seeds; when they grow together in clusters, each fruit is called a seed.

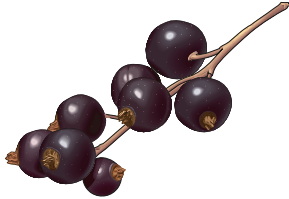
**black currant**

Black berry primarily used to make coulis, jellies, wine and liqueurs such as crème de cassis, an ingredient in kir.

**currant**

Small red or white currant primarily eaten cooked due to its sour taste; its juice can replace vinegar in salad dressing.

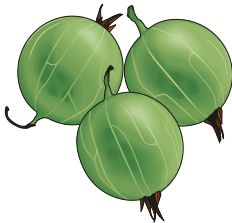
**gooseberry**

Larger than the clustered berries, it is especially popular in Europe; the British use it to make a chutney that is served with mackerel.

**blueberry**

Little known outside its native North America, it is primarily eaten plain or in desserts; the lowbush variety is the sweetest.

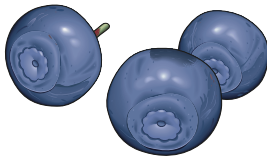
**bilberry**

Although not related to it, this berry of Europe and Asia resembles the blueberry and is used like it.

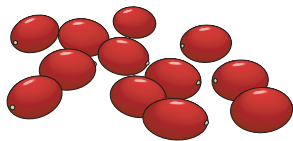
**red whortleberry**

Closely related to the cranberry, this small tart berry is somewhat bitter and rarely eaten raw; it is used instead to make sauces, jams and desserts.

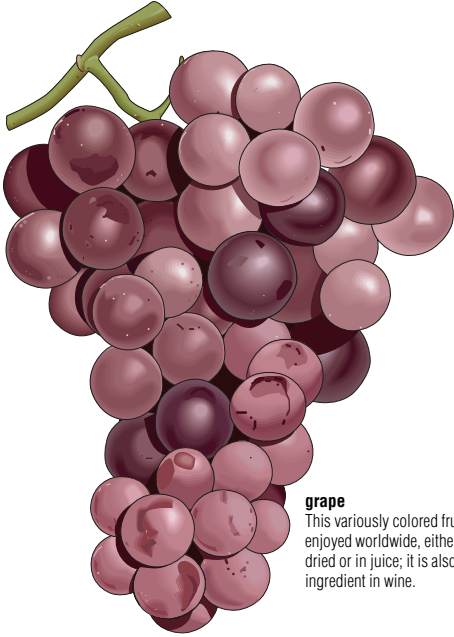
**grape**

This variously colored fruit of the vine is enjoyed worldwide, either plain, cooked, dried or in juice; it is also the main ingredient in wine.

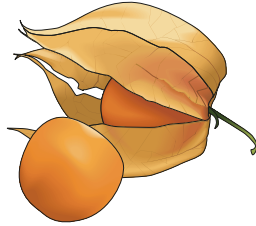
**alkekengi**

Covered in a thin, inedible membrane, it is slightly tart and not very sweet; it is often used to make jams and jellies because of its high pectin content.

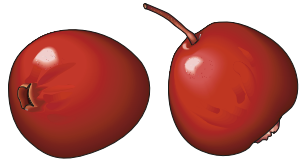
**cranberry**

Too tart to be eaten raw, it is primarily used for making desserts, sauces or juice; a traditional accompaniment to turkey in North America.

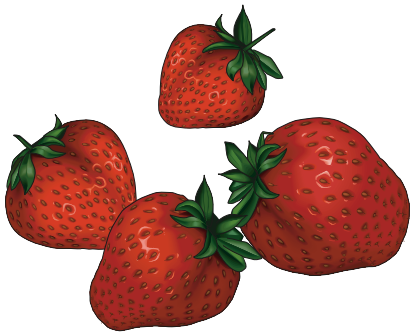
**strawberry**

The cultivated strawberry was bred from the smaller and more fragrant wild strawberry; it is very flavorful and is used raw or cooked, primarily in desserts.

Grows on canes as does the raspberry, and is used like that fruit; not to be confused with the fruit of the bramble bush, which grows several meters high.

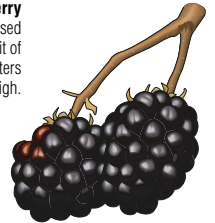
blackberry**raspberry**

Generally red, there are also different-colored varieties; slightly tart and very fragrant, it makes an excellent coulis that can be incorporated into desserts.

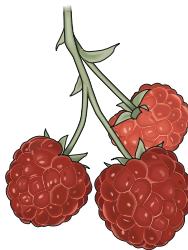

dry fruits

Often called nuts, these fruits usually have a hard dry covering called the shell that encloses an edible kernel.

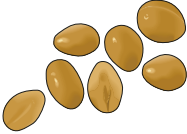
**ginkgo nut**

Extensively used in Japanese cooking but little known in the West, this nut is either eaten as is or is used in Asian dishes.

**pistachio nut**

Its greenish kernel is covered with a brown skin; it is extensively used in Mediterranean and Asian cooking, as well as in pastry and candy making.

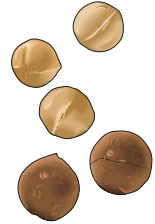
**macadamia nut**

A popular candy ingredient, it is often sold coated in chocolate or honey; it is also a popular ingredient in mixed vegetables, curries, salads and desserts.

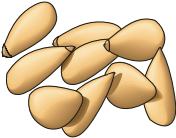
**pine nut**

Edible seed inside the cone of certain species of pine that is often used in cooking and baking.

**cola nut**

Used in drink preparations such as Coca-Cola™; it contains stimulants that are slightly less potent than those in coffee.

**pecan nut**

Native to North America, it is used to make certain savory dishes and numerous desserts, such as the traditional pecan pie.

**cashew**

This fruit of the cashew tree is always sold shelled; its shell is covered by a juicy fleshy edible layer known as the cashew apple.

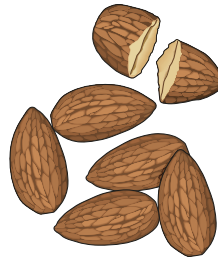
**almond**

Primarily used to garnish chicken and fish, and to make almond paste, candies (nougat and pralines) and an essence that flavors Amaretto and a variety of foodstuffs.

**hazelnut**

Primarily used to make paste, butter or a kind of flour used in cakes and cookies; in candy making, it is often combined with chocolate.

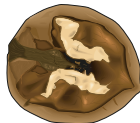
**walnut**

A green covering, the husk, covers the shell; the walnut is served as an appetizer, or added to a variety of desserts, salads, sauces and main dishes.

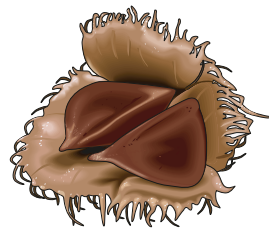
**beechnut**

Fruit of the common beech tree, its flavor resembles the hazelnuts; more flavorful toasted than raw, it also yields a cooking oil.

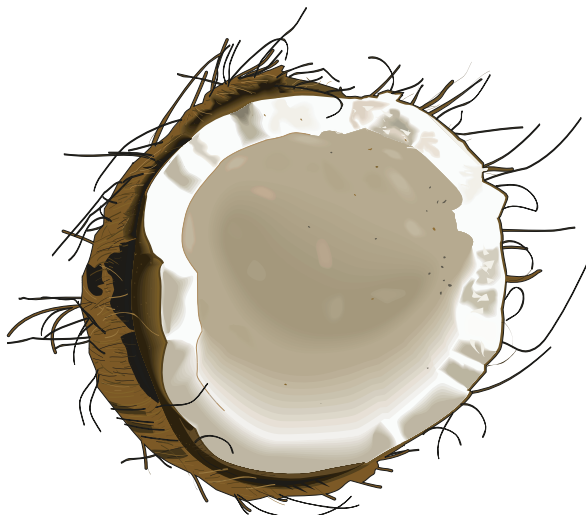
**coconut**

The whitish meat, known as copra, surrounds a cavity containing a refreshing liquid, not to be confused with coconut milk, which is derived from the grated flesh.

**chestnut**

Designates the fruit of the chestnut tree; Europeans often serve it with game and poultry. When puréed, it is the main ingredient in the dessert known as Mont Blanc.

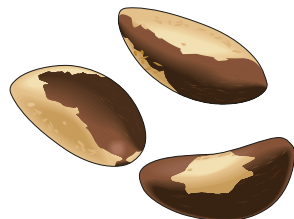
**Brazil nut**

Often served as an appetizer; it is also made into candy, such as when chocolate-coated. It replaces coconut in some recipes.

fruits

citrus fruits

Somewhat acidic fruits with a high vitamin C content comprising numerous sections and covered with a rind that has an external layer called zest.

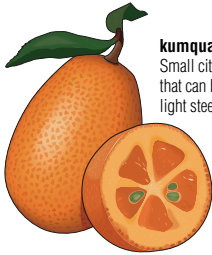
**kumquat**

Small citrus fruit, .75 to 2 in long with a sweet tender rind that can be eaten unpeeled; its flavor is enhanced through light steeping.

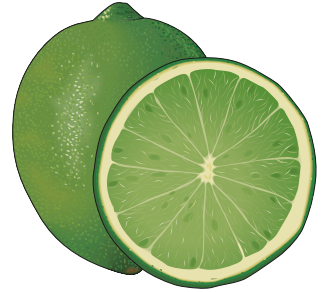
**lime**

Intensely fragrant and used like the lemon; it is an essential ingredient in ceviche, a raw marinated fish dish.

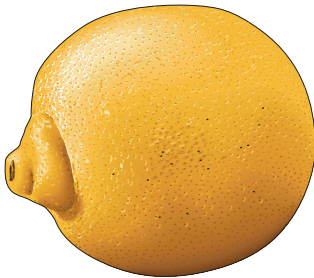
**bergamot**

Because its greenish flesh is inedible, it is primarily used for the zest and essential oil derived from its rind, especially in Earl Grey tea.

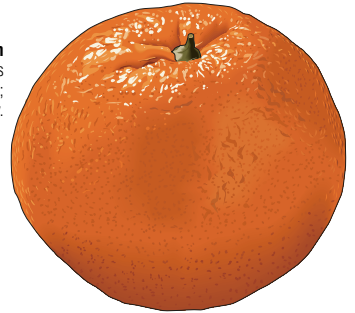
**mandarin**

Similar to a small, slightly flattened orange, it is less acidic than most citrus fruits and is often eaten as is; it peels easily.

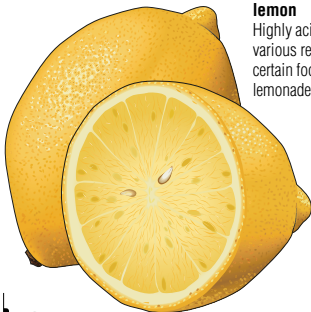
**lemon**

Highly acidic, it is especially used to flavor various recipes and enhance the flavor of certain foods; it is the main ingredient in lemonade.

orange
Widely available, it is often eaten plain or in juice, and it goes well with duck; it yields a flavor essence and an essential oil.

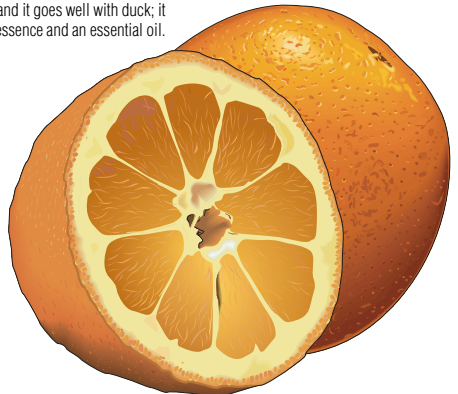

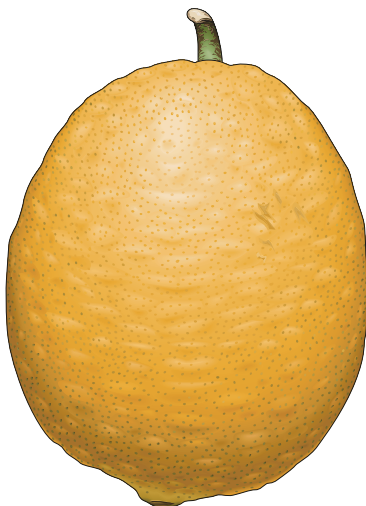
**citron**

Extensively grown in Corsica and Israel, this somewhat dry fruit is rarely found fresh and is mostly sold candied.

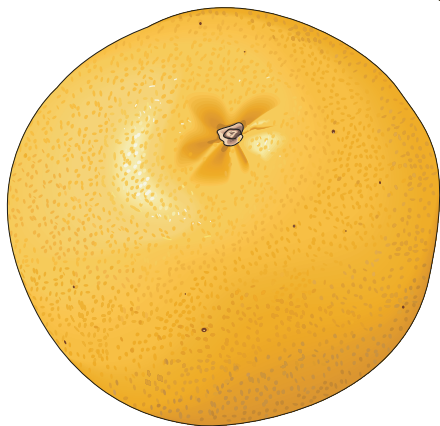
**grapefruit**

The pink grapefruit is sweeter and less bitter than the white one that has yellow flesh; it is often cut in half and eaten plain, with a spoon.

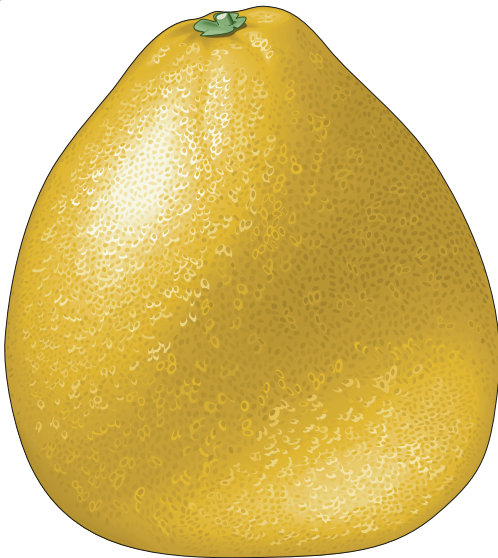
**pomelo**

Extremely popular in many Asian countries, it has only recently become available in the West; less juicy than the grapefruit, it is mostly cooked or candied.

melons

Related to squash and cucumbers, these tender fruits are juicy sweet and refreshing; they are primarily consumed raw.

honeydew melon

Owes its name to its very sweet, green flesh; its smooth firm rind turns creamy-yellow as it ripens.

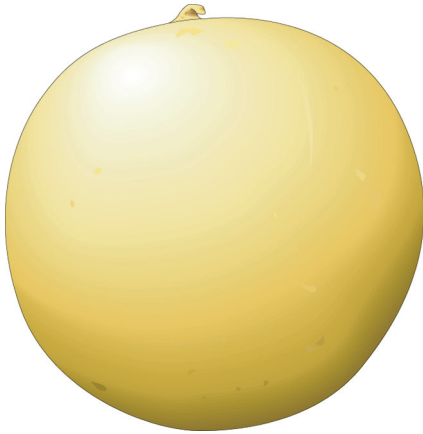
**casaba melon**

The flavor of its creamy white flesh, often less fragrant than that of other melons, can be enhanced with lemon or lime juice.

**muskmelon**

Named for the characteristic musky smell of its flesh; it has a textured rind and its flavorful flesh is pink or orange.

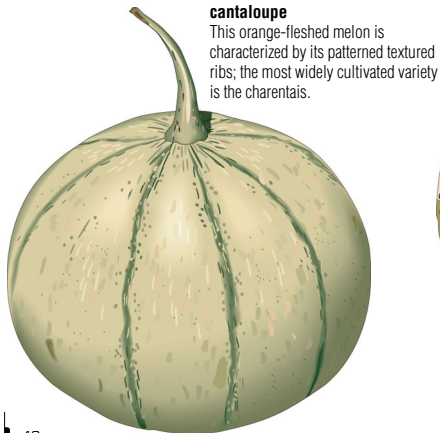
**cantaloupe**

This orange-fleshed melon is characterized by its patterned textured ribs; the most widely cultivated variety is the charentais.

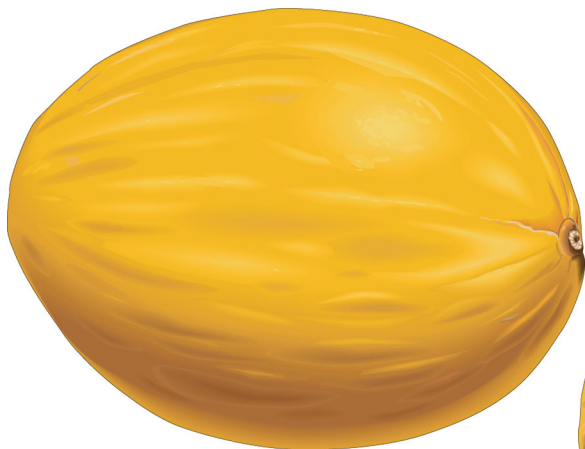

**canary melon**

Has sweet whitish flesh that is rose-tinted near the central cavity; it becomes very fragrant when ripe.

Ogen melon
Small round melon with a hard smooth ribbed rind; its very juicy flesh is either dark pink or pale green.



watermelon
This thirst-quenching fruit, named for its high water content, is primarily eaten plain, in slices.



pome fruits

Fruits where the flesh covers an inedible central part, the core, comprising a certain number of seeds called pips.

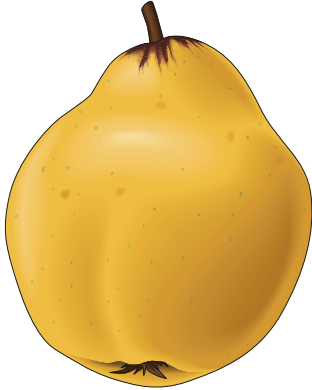
**quince**

Fruit of the quince tree, native to warm climates; inedible raw, it is traditionally made into jams and jellies.

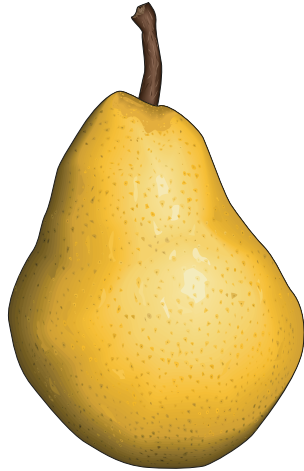
**pear**

Among its many and varied uses, it forms the basis for a fruit brandy; it is picked before fully ripe to prevent the flesh from acquiring a granular texture.

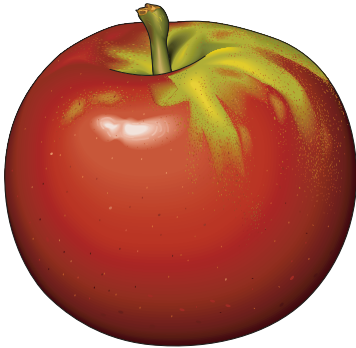
**apple**

There are 7,500 known varieties; it is used to make cider and is also eaten raw or made into juice, jelly, compote or desserts, such as pie or strudel.

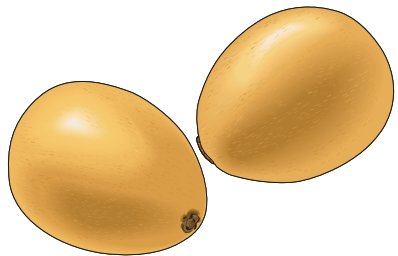
**Japanese plum**

Has thin skin, sometimes covered in fine hairs, that envelops juicy, somewhat sour flesh; whether raw or cooked, it tastes somewhat like cherries or plums.

tropical fruits

A variety of fruits, usually of exotic origin, more or less available in the West.

**kiwi**

Its juicy, slightly acidic green flesh has a high vitamin C content; delicious plain, its downy skin is generally discarded, although it can be eaten.

**tamarillo**

Within the inedible skin there is a firm, slightly acidic flesh. If very ripe, it can be eaten raw; otherwise, it is often cooked like a vegetable.

**longan**

Stone fruit, related to the litchi, whose whitish translucent flesh is sweet and juicy; the peeled and stoned fruit is often eaten plain.

**horned melon**

Its green flesh contains soft edible seeds, similar to those of the cucumber; it is often peeled and then made into juice.

**mangosteen**

Within the inedible skin that hardens as the fruit ages, there is a sweet juicy white flesh that is divided into sections; it is eaten as is, like an orange.

pineapple

Once the inedible rind has been removed, it is eaten raw, cooked or in juice; in North America, it is traditionally served with ham.

**banana**

Eaten as is, sautéed, fried or flambéed with rum; it is a classic garnish for ice-cream dishes and is also used in muffins and cakes.

**plantain**

Nicknamed the "cooking banana", this staple of African and West Indian cooking is inedible when raw; it is primarily eaten as a vegetable, either steamed, roasted or fried.

**jackfruit**

This very large fruit has edible seeds that can be boiled or roasted; the starchy flesh is eaten as a fruit or vegetable, either raw or cooked.

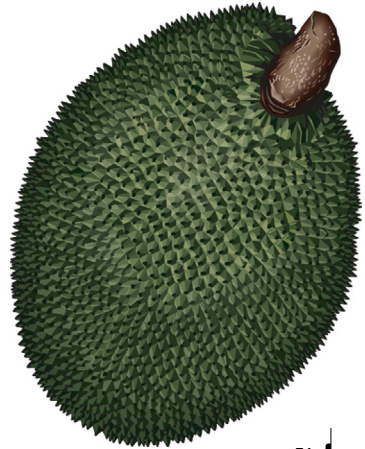

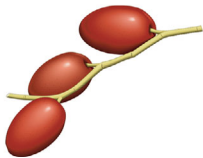
**jujube**

Somewhat dry stone fruit, eaten fresh or dried, raw or cooked, like the date.

**jaboticaba**

Little known outside Brazil, it is eaten as is, like grapes, or made into jelly, jam, juice or wine; its translucent flesh is either white or pink.

**litchi**

Its juicy crunchy translucent flesh is more fragrant than the longan's; it is often eaten raw and the Chinese serve it with fish or meat.

sapodilla

Has juicy fragrant, slightly granular flesh that tastes like honey and apricots; it is easy to peel and is eaten raw or cooked.

**guava**

Very popular in South America, its fragrant, slightly acidic flesh is eaten raw or cooked, with or without the skin and seeds.

**Japanese persimmon**

This national fruit of Japan is often eaten plain, with a spoon; the fuyu variety is eaten like an apple.

**rambutan**

The shell, covered in soft spikes, splits easily to reveal flesh like the litchi's but less fragrant; it is used like the litchi.

**fig**

Among its many varieties are the black, the green and the purple fig; whether fresh or dried, it is mostly eaten raw, but can also be cooked.

**passion fruit**

Within its inedible skin that wrinkles when ripe, there is a highly aromatic gelatinous pulp; delicious plain, it is used to flavor fruit punches and cocktails.

**pomegranate**

The edible part is the small, very juicy berries enclosed within the fruit's membranes; it is used to make grenadine syrup, an ingredient in drinks and desserts.

**prickly pear**

Fruit of a member of the cactus family; the spines and skin should be removed before eating the flesh, plain or sprinkled with lemon or lime juice.

**carambola**

Within the delicate edible skin is a juicy, slightly acidic flesh that can be eaten raw or cooked, as a fruit or vegetable.

**Asian pear**

Most popular Asian fruit, primarily eaten plain; its flesh is sweet and juicy, like the pear's, and crunchy, like the apple's.

**mango**

Fruit with a flattened stone and a skin that should be discarded, as it irritates the mouth; it is mostly eaten ripe, but sometimes used green, as a vegetable.

**feijoa**

Has sweet fragrant, slightly granular flesh; after peeling, it is eaten raw or cooked, plain or in various desserts.

**cherimoya**

The skin and the seeds inside the slightly granular flesh are inedible; the flesh is sprinkled with orange juice and eaten with a spoon.

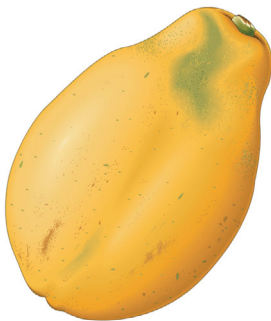
**papaya**

Its usually orange, juicy flesh is eaten like the melon and contains spicy, edible seeds; when green, it is eaten like winter squash.

**pepino**

The orange or yellow flesh is slightly starchy. Before fully ripe, it is often cooked and prepared like a squash; once ripe, it is eaten like a melon.

**durian**

Large fruit that emits a disagreeable odor when ripe; its sweet creamy flesh is often eaten plain while the seeds are used like nuts.

spices

Plant substances, often of exotic origin, used primarily for their flavor and pungency to enhance the taste of various recipes.

**juniper berry**

Fruit of the juniper tree with a resinous smell and slightly bitter flavor; it is the basis for gin and also flavors marinades, sauerkraut, meat and pâtés.

**clove**

The dried floral bud of the clove tree. Whole, it is often used with ham or simmered onion dishes; when ground, it flavors items such as gingerbread.

**allspice**

Also called Jamaican spice; it is used to flavor savory or sweet dishes and certain liqueurs.

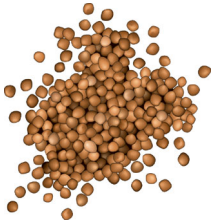
**white mustard**

Its seeds are larger and less pungent than the black mustard's and are used especially to make American mustard.

**black mustard**

The flavorful pungent seeds have a high concentration of essential oil; they are used whole, ground or as a flavoring agent.

**black pepper**

The most pungent and aromatic of the peppers, it comes from small berries that are picked while still green, then dried.

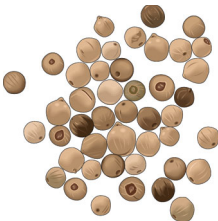
**white pepper**

Small berries picked when very ripe, then dried and skinned; this pepper is less pungent than black pepper.

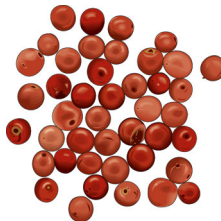
**pink pepper**

These dried berries, with a delicate fragrant and mildly pungent flavor, do not grow on the pepper tree but on another plant; it is used like pepper.

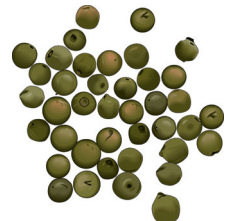
**green pepper**

Small berries picked while still green and usually dried or preserved in brine or vinegar; this pepper is mild but very fragrant.

**caraway**

Its sharp bitter flavor enhances the flavor of stewed dishes; it is used primarily in Eastern Europe, India and Arab countries.

**saffron**

The most expensive spice, actually derived from the handpicked and dried stigmata of the crocus flower; it is an essential ingredient in paella and bouillabaisse.

**cumin**

Extensively used in traditional Arab, Indian and Mexican dishes, it has a strong smell and a warm, slightly bitter flavor.

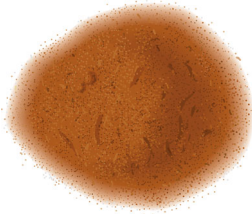
**curry**

A staple of Indian cooking, the pungency of this blend of spices varies, depending on how much pepper or chile is used.

**turmeric**

Similar to ginger, it is cooked and ground into powder; among other uses, it is added to Indian curries and chutneys and provides the color for American mustard.

**fenugreek**

Once roasted, the seeds have a bittersweet aftertaste; they are used in Indian cooking or, when sprouted, added to salads.

**nutmeg**

Its flavor complements milk products but quickly decreases once the nut is ground; its red membrane, known as mace, is also used as a spice.

**cardamom**

The pod is green, brown or white, depending on whether it was sun- or oven-dried, or bleached; its delicate peppery flavor characterizes Indian curry.

**cinnamon**

Dried bark of the cinnamon tree, sold in sticks, ground or as an essential oil; it is often associated with candy, sweet dishes and hot drinks.

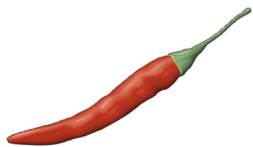

bird's eye chile

Small, intensely hot chile; removing the seeds and interior membranes alleviates the fiery taste.



jalapeño chile

Relatively mild chile, native to Mexico and sold fresh, dried or marinated; it turns red when ripe.



crushed chiles

Dried crushed chiles that contribute flavor and spiciness to a variety of recipes; they are commonly used in pasta dishes.



dried chiles

The smaller dried chiles are generally stronger than the large ones, which can be dry-roasted before use to bring out their flavor.



cayenne chile

Dried red chile powder used specifically to make Tabasco® sauce; it is so hot that one pinch is enough to season an entire dish.



paprika

Extensively used in Hungarian cooking, this somewhat hot powder combines dried sweet red pepper and red chiles; it is used to flavor and color numerous foods, such as eggs and potatoes.



ajowan

Highly fragrant, it tastes like thyme; among other uses, it is added to starchy foods, legumes and Indian wafers.

asafetida

The dried gum derived from two species of giant fennel, its unpleasant smell dissipates with cooking; it adds flavor to vegetables, fish and Indian sauces.



garam masala

Indian spice blend of which there are countless varieties, some numbering up to 12 ingredients; it is used to season pilafs and meat dishes.



cajun spice seasoning

Its spiciness enhances the flavor of ragouts and Cajun dishes; it is also sprinkled on meat and fish before they are barbecued or roasted.



marinade spices

A mixture of spices added to fruit and vegetable preserves, chutney and vinegar; its composition varies.



five spice powder

A blend of five ground spices used in Chinese cooking; it includes star anise, cloves, fennel seeds, cinnamon and pepper.



chili powder

Spice blend composed mainly of dried ground chiles, whose strength varies depending on the chiles used; it is widely used to flavor and color rice and pasta.



ground pepper

Although one of the most widely used cooking spices, it loses its flavor faster than peppercorns, from which it is derived.



ras el hanout

Very fragrant Maghrebian spice blend with dried flowers among its up to 50 ingredients; it is used to flavor game, couscous, rice and stews called tajines.



sumac

Dried berries, sometimes ground, with a slightly acidic, lemony taste; it is very popular in the Middle East, especially in salads and fish dishes.

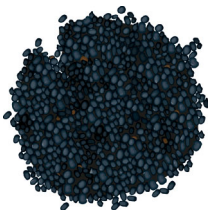

poppy seeds

Their nutty flavor, which intensifies with cooking, works especially well in bread, cakes and pastries; it also yields a cooking oil.



ginger

A staple of Asian cooking and a classic garnish for sushi; it is also used ground, especially in breads and cookies.

condiments

Natural or artificial substances used in cooking to bring out the flavor in a dish or to complement it.

**Tabasco® sauce**

Native to Louisiana, this sauce is made from crushed red chile peppers and is so pungent that a few drops are enough to season a whole dish.

**Worcestershire sauce**

British sauce whose exact recipe is kept secret by the manufacturer; its robust flavor goes well in cocktails, sauces, soups and many other dishes.

**tamarind paste**

Made from the fruit of the tamarind tree, this slightly acidic paste is used as a foodstuff and as a condiment in Asian cooking.

**vanilla extract**

Aromatic substance extensively used in baking; it is often made of artificial ingredients that are less tasty than real vanilla, which is more expensive.

**tomato paste**

Tomato coulis reduced until it turns into a paste; it is used to make ragouts and sauces.

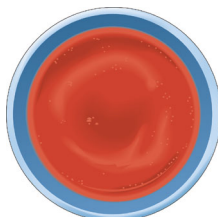
**tomato coulis**

Tomato purée of medium thickness that is served either hot or cold, as a sauce.

**hummus**

Lebanese condiment made from puréed chickpeas and sesame oil, commonly served as an hors d'oeuvre or with crudités.

**tahini**

Thick creamy nutty-tasting paste, made of ground sesame seeds; it is added to sauces and served with brochettes, bread, fruit and vegetables.



hoisin sauce

Thick spicy sauce made from soybeans and dried chiles; it enhances braised foods, is served with Peking duck and is used as a marinade.

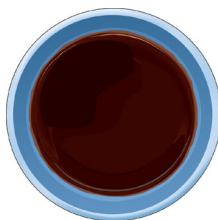

soy sauce

A key condiment in Asian cooking, this extremely salty sauce is made from soybeans and is used as a flavoring ingredient, dip or marinade.

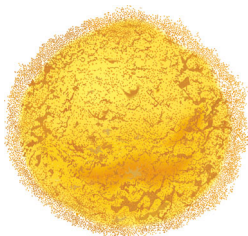

powdered mustard

Can be incorporated into shortening, used as a seasoning or mixed with water to make a paste that resembles prepared mustard.



wholegrain mustard

Native to Meaux, France, this mild spicy mustard is made from partly crushed seeds, giving it a grainy texture.



Dijon mustard

This strong mustard comes from Dijon, France; it is served with meat and is used in making sauces, salad dressings and various kinds of mayonnaise.

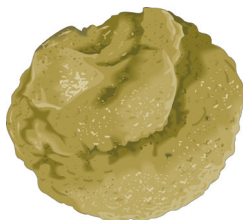

German mustard

Medium strong and slightly sweet mustard that goes well with sausages and deli meats.



English mustard

Very strong mustard, sold either prepared or powdered, traditionally served with roast beef and ham.



American mustard

Very mild, the traditional North American accompaniment to hot dogs and hamburgers; its bright yellow color comes from turmeric.

**plum sauce**

Sweet-and-sour Chinese sauce primarily served with deep-fried or roasted dishes, such as pork and roast duck.

**mango chutney**

Thick sweet-and-sour relish, originating in India and made with mangoes, sugar and vinegar; it can be served with a variety of dishes.

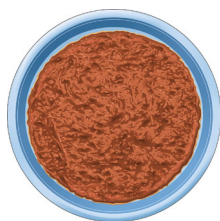
**harissa**

This chile-based purée is very popular in the Middle East and North Africa; it is used as is or mixed with broth and is a key ingredient in couscous.

**sambal oelek**

Very spicy Indonesian sauce made from chiles; it is used as a flavoring ingredient, condiment or hors d'oeuvre sauce.

**ketchup**

Medium spicy, traditionally English tomato purée made from numerous different recipes.

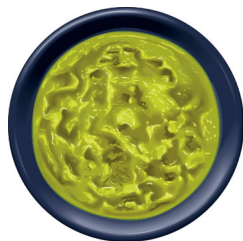
**wasabi**

Its very pungent taste enhances meat and fish dishes, such as Japanese sushi and sashimi.

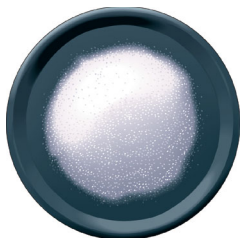
**table salt**

A standard table condiment and also commonly used in cooking, it is always refined.

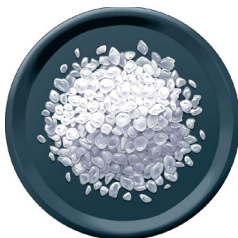
**coarse salt**

This somewhat refined version is sometimes used in cooking or to sweat vegetables and preserve foods.

**sea salt**

Unlike rock salt, which is whiter and comes from the subsol, this usually grayish salt is derived from seawater through evaporation.

**balsamic vinegar**

Well-known condiment made from sweet white grapes and aged in wooden casks; its low acidity makes it ideal for use in salads or in hot foods.

**rice vinegar**

It is made from fermented rice wine and is very popular in Asian cooking; the Japanese version is sweet while the Chinese one is spicier.

**apple cider vinegar**

Cider-based product whose strong taste makes it unsuitable for salads; it is used primarily for deglazing or as an ingredient in fish and seafood dishes.

**malt vinegar**

Made from sprouted barley juice, it is much too strong for salad dressings; it is used instead to make mixed pickles and chutneys.

**wine vinegar**

White wine vinegar is less fragrant than the red; the former goes well with fish and seafood while the latter brings out the flavor of blander foods.

herbs

Aromatic fresh or dried plants used separately or mixed to bring out the flavor of recipes; they often make excellent infusions.

**dill**

Used primarily for its leaves and seeds, it imparts flavor to vinegar and pickles as well as to salmon and herring.

**anise**

Extensively used in making candy (licorice) and liqueurs (pastis), its edible leaves and seeds can flavor savory as well as sweet dishes.

**sweet bay**

The dried leaves must be used sparingly; it is an ingredient in bouquets garnis and is used to flavor soups and stews.

**oregano**

Wild, slightly more flavorful variety of marjoram; extensively used in Mediterranean cooking, it goes especially well with tomato dishes.

**basil**

A popular choice for seasoning tomato and pasta dishes, it is also one of the main ingredients in pistou and Italian pesto.

**sage**

Its pungent flavor complements a variety of dishes; it is often used with pork, duck and goose, as well as in Italian veal dishes.

**tarragon**

Has a slightly bitter, peppery anise flavor that complements bland foods; it is often used with chicken and is always used in béarnaise sauce.

**thyme**

Used with parsley and sweet bay to make bouquets garnis; because it withstands lengthy cooking, it is a popular choice for flavoring soups and stews.

**mint**

Gives a refreshing taste to numerous sweet and savory dishes, such as lamb; its aromatic essential oil is used to flavor candy, liqueurs and many other types of food.

**parsley**

The smooth flat-leaved parsley is less bitter and more fragrant than curly-leaved parsley; it is used to flavor numerous recipes, such as tabbouleh.

**chervil**

Has a subtle delicate taste and is used like parsley; it is often included with tarragon, parsley and chives in a traditional blend known as fines herbes.

**savory**

Reminiscent of thyme, its flavor enhances legumes, meat and stuffing; it is also used to flavor vinegar and goat's milk cheeses.

**coriander**

Its leaves are used like parsley and it has edible musk- and lemon-scented seeds; the roots can be substituted for garlic.

**hyssop**

The highly aromatic leaves are mostly used in salads, soups, ragouts and fruit platters, as well as in some liqueurs, such as Chartreuse and Benedictine.

**borage**

Delicious in yogurt, cream cheese or salad dressing; the young leaves can be used in salads.

**rosemary**

Its fairly pungent, aromatic flavor is very popular in southern France and in Italy, where it is used especially in sauces and marinades, and with roast meat.

**lovage**

Resembles celery but with a stronger flavor; it is particularly tasty with potatoes and also goes well with ragouts, sauces and salads.

**lemon balm**

Its lemon-scented leaves are used extensively in Asian cooking; it goes well with bitter foods.

cereal

Plants that are often cultivated on a large scale; their grains have been a major food staple for humans and

**rice**

A universal staple, used as a side dish, in sweet and savory dishes such as risotto and paella, and for its by-products (noodles, sake).

**wild rice**

Seeds from a North American aquatic plant; it is richer and higher in protein than rice and has a strong nutty flavor. It is sometimes mixed with other kinds of rice.

**speltz wheat**

Wheat variety with small brown grains that, once hulled, can be used like rice.

**wheat**

Cereal cultivated for its grain, of great significance in human food production; it is used to produce foodstuffs such as flour, bread and semolina.

**oats**

Often eaten as porridge, it is also an ingredient in date squares, fruit crisp toppings, muffins, cookies and pancakes.

**rye**

Yields a flour that can be combined with wheat flour to make bread; it is also used in brewing (beer) and distilling (whisky).

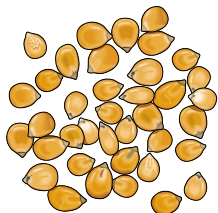
**corn**

Native to America, it is eaten as a vegetable, made into popcorn or ground into flour; it also yields a starch, a syrup and a cooking oil.

buckwheat

Eaten in soups and as porridge, it is also ground into a flour traditionally used to make crepes and pancakes.

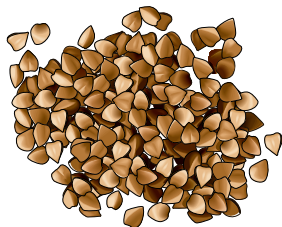
**millet**

With its strong flavor, it is mostly used for making pancakes and porridge; when sprouted and ground, millet is an ingredient in breads and muffins.

barley

Barley can be either hulled or pearled to remove its outer husk; it is often added to soups and ragouts and is also made into malt for brewing beer.

**triticale**

A wheat and rye hybrid, it is mostly used to make crepes and pasta.

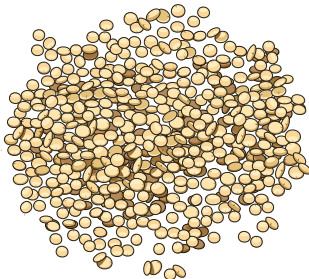
**quinoa**

Grains should be thoroughly rinsed before cooking; it is used in South America to make an alcoholic drink called chicha.

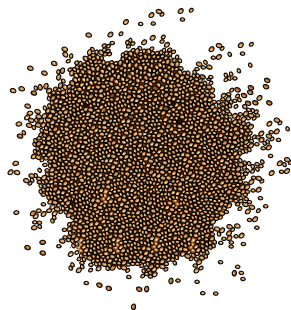
**amaranth**

These highly nutritious, slightly peppery grains can be eaten as is after cooking, sprouted or ground into flour.

cereal products

Cereals that have been processed in various ways to make ground (flour, semolina), unground (rice) or manufactured products (bread, pasta, noodles).

flour and semolina

Products obtained by grinding grains and cereals; semolina is usually coarser and more granular than flour. Without a modifier, these words generally refer to wheat.

**all-purpose flour**

This blend of ground hard and soft wheat has many uses, but is primarily used to thicken sauces or to make bread and pastry.

**unbleached flour**

Like white flour, it comes from grinding wheat grains from which the bran and germ have been removed, but it is not artificially whitened.

**oat flour**

Since it does not rise during cooking, it must be combined with wheat flour to make bread and other leavened products; it makes these products heavier.

**corn flour**

Primarily added to crepe, cake, muffin and bread mixes; it must be combined with wheat flour if the mixture is intended to rise.

**semolina**

Refers to the granular flour derived from hard wheat, used to make pasta; fine semolina can also be eaten as a cereal (cream of wheat).

**COUSCOUS**

Hard wheat semolina that is formed into grains and used to prepare an eponymous dish of the Maghreb; it is traditionally steamed over broth.

**whole-wheat flour**

Because it is produced by grinding the entire grain, none of the nutrients is lost; the grain's outer layer, known as bran, gives it a brownish color.

rice

Rice is commercially classified by the shape of the grain and the processing it has undergone before being packaged.

**white rice**

Milled rice from which the bran and germ have been removed; it is often enriched to compensate for the loss of nutrients.

**brown rice**

Because it is not hulled, the grains retain the bran and germ; it is highly nutritious and has a stronger flavor than white rice.

**parboiled rice**

More nutritious than white rice, it has undergone a steam pressure process prior to milling, to preserve the grains' vitamin and mineral content.

**basmati rice**

Variety of fine-grained rice native to India, it is known and prized for its aroma and light texture.

cereal products

bread

Food made from flour, water and salt, often containing an agent (leaven or yeast) that makes it rise.

**bagel**

Jewish ring-shaped roll traditionally coated in sesame seeds; it is usually served warm, with cream cheese.

**croissant**

A small roll of layered or puffed dough, frequently eaten as a plain or stuffed pastry; it is also used to make hors d'oeuvres and sandwiches.

**black rye bread**

Made from rye flour, this dense strong-tasting bread goes particularly well with seafood and smoked foods.

**ear loaf**

Baguette made so it can be easily broken into pieces by hand.

**Greek bread**

Round loaf with a golden crust, sometimes sprinkled with sesame seeds; olive bread is one of its many variants.

**baguette**

This light crusty, typically French bread is often served with a meal and also goes well with cheese and pâté; it must be eaten fresh.

French bread

Long crusty loaf resembling an oversized baguette; it stays fresh somewhat longer than the typical baguette.





Indian chapati bread

Flat crusty, slightly puffy bread, eaten warm with vegetables and rice or used as a spoon to scoop up food.



Indian naan bread

The yogurt in the dough of this soft light sweetish bread helps it rise; it is eaten plain or stuffed.



phyllo dough

Flexible water-thin dough of Greek origin, used to prepare hors d'oeuvres and pastries, such as baklava.



unleavened bread

Light and crusty unleavened bread, eaten mainly during Jewish Passover; it is easily digested and has a long shelf life.



pita bread

Flat bread originally from the Middle East; its crust forms a pocket that can be filled with hot or cold kinds of stuffing.



tortilla

Disk of unleavened bread made with corn flour that is the basis for many Latin-American dishes; it can be eaten plain, with a filling or cooked.



Russian pumpernickel

Made with a mixture of wheat and rye flour, it has a thin but resilient crust; it goes well with soups and ragouts.



German rye bread

Dark dense bread with a strong, slightly acidic taste, made with rye and wheat flour; it has a long shelf life.



cracked rye bread

Thin crusty flat bread made with rye flour, usually eaten with cheese.



Danish rye bread

This bread is usually sweeter and lighter than German rye bread; it often contains molasses.



Jewish hallah

Light soft sweetish bread traditionally served on the Sabbath and other Jewish festivals; it is usually braided.



Scandinavian cracked bread

Thin crusty flat bread usually made with wheat or rye flour; it is generally served with soup, salad or cheese.



Irish bread

The crust of this bread is marked with a cross; it is made with baking powder, which gives it a cakelike consistency.



American corn bread

The crumb of this corn flour-based bread is golden in color; it is easy to make and very popular in the southern United States.



English loaf

Thin-crustured, round or rectangular bread of British origin; it is primarily used to make toast, canapés, croque-monsieurs and sandwiches.



white bread

Bread made with white flour that comes in a variety of shapes, thickness and textures; it is less nutritious than wholemeal bread.



multigrain bread

Usually contains 80% white flour, whole wheat flour or a mixture of the two, to which other cereals (oats, rye, etc.) are added.



farmhouse bread

Its thick, often floury crust and slightly acidic-tasting interior can last a long time without becoming stale; it can be used in a variety of ways.



wholemeal bread

Because it is made with whole wheat flour, it is highly nutritious and contains more minerals and protein than white bread.

cereal products

pasta

Made from hard wheat semolina and water, shaped into various forms and dried; it is an essential ingredient in Italian cooking that is bought ready-made.

**rigatoni**

This fairly large tubular pasta is suitable for serving with all kinds of sauces because they cling to it readily.

**rotini**

Because of its spiral grooves, it readily holds meat, cheese and vegetable sauces; it is also ideal for salads.

**conchiglie**

Small shell-shaped pasta that can be served with a sauce or added to soup or pasta salads.

**fusilli**

This spiral-shaped pasta is thinner and longer than rotini, but can replace it in most recipes.

**ditali**

Short tube-shaped pasta that resemble fat macaroni, used especially in broth and vegetable soups.

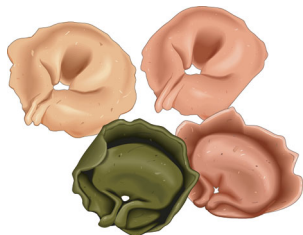
**tortellini**

Pasta stuffed with meat or cheese and sometimes colored with tomato or spinach; it is delicious with tomato or cream sauce.

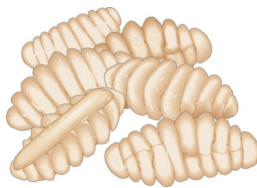
**gnocchi**

Often made from a potato or semolina dough with eggs and cheese; it is usually served au gratin, as an appetizer.

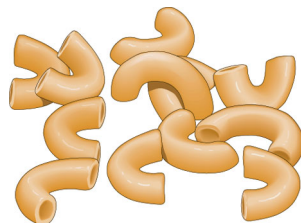
**elbows**

Sometimes used in a salad, this type of macaroni is also served with tomato or cheese sauce.

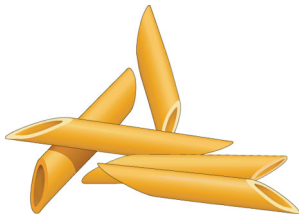
**penne**

Tube-shaped pasta with diagonally cut ends, often served with a spicy tomato sauce in a dish called penne all'arrabiata.

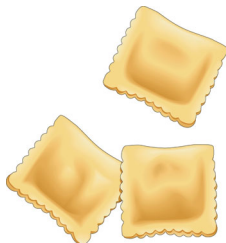
**ravioli**

Pasta stuffed with meat, cheese or vegetables; a classic way to serve it is with tomato sauce, sprinkled with grated Parmesan.

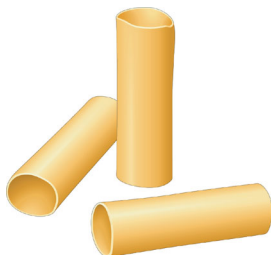
**cannelloni**

This fairly large tubular pasta is usually stuffed with meat or cheese, covered with tomato sauce and baked au gratin.

spaghetti

One of the best-known forms of pasta and the most extensively used; it is traditionally served with tomato or meat sauce.

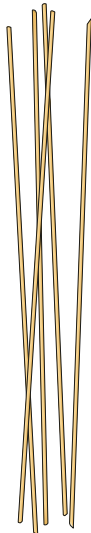
**spaghettini**

Thinner than spaghetti but thicker than angel hair pasta or vermicelli noodles; it is particularly well suited to delicate sauces.

fettucine

Thicker but not as wide as tagliatelle, this pasta is often served with Alfredo sauce.

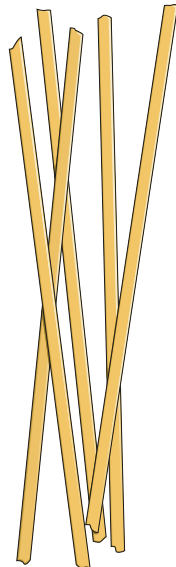
**spinach tagliatelle**

Flat ribbonlike pasta made with spinach and eggs, traditionally served with meat sauce.

**lasagna**

These wide strips, green if spinach-flavored, are combined with a filling in alternate layers to create the eponymous dish.

Asian noodles

This pasta is a staple of Asian cooking; generally classified according to its main ingredient: wheat, rice, buckwheat or mung beans.

**rice noodles**

Wide ribbons made with rice flour and water; they are often added to soup.

**bean thread cellophane noodles**

Transparent noodles made with mung bean flour; before adding them to a recipe, they must be soaked in hot or warm water.

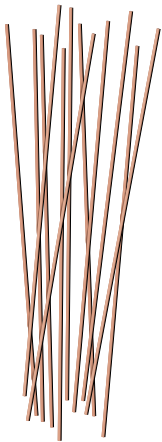
**soba noodles**

Made with buckwheat flour, these noodles are used extensively in Japan, where they are mainly served cold, with soy sauce.

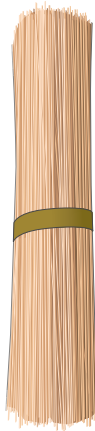
**somen noodles**

Fine whitish Japanese wheat noodles that go particularly well in salads and soups.

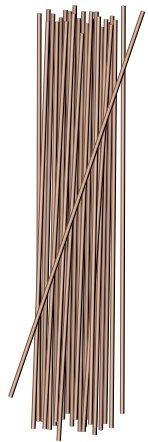
**udon noodles**

These Japanese wheat noodles are thicker than somen noodles; among their various uses, they can be added to soup, salads and sautéed dishes.

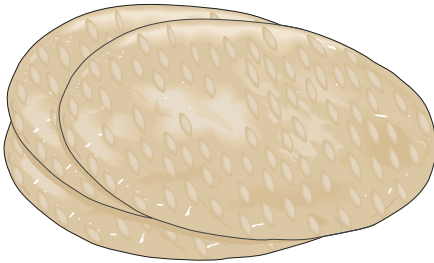
**rice papers**

Thin semitransparent sheets made with rice flour, used in Asia to prepare spring and imperial rolls.

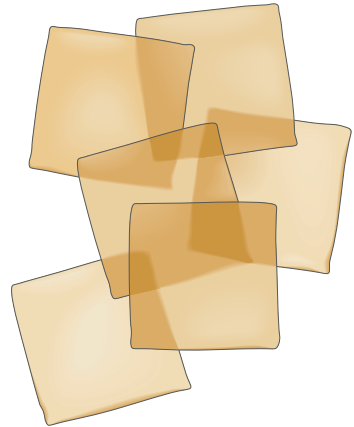
**won ton skins**

Delicate sheets of wheat pasta that are stuffed with meat, seafood or vegetables; an essential ingredient in won ton soup.

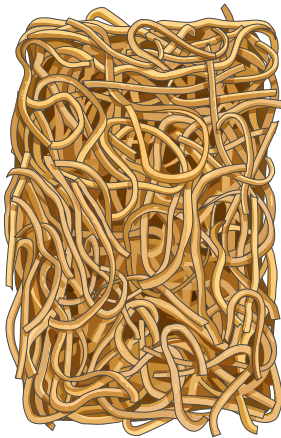
**egg noodles**

Wheat noodles made with eggs; they are boiled in water, then fried and used to make chow mein.

**rice vermicelli**

Fine rice noodles that are fried in oil and shaped into a nest that is filled with various kinds of Asian food.

coffee and infusions

Aromatic beverages derived from ground beans (coffee) or dried plants (tea, herbal tea) that are combined with boiling water.

coffee

The seeds of the coffee tree can be used to prepare an extremely popular beverage, drunk hot or cold (iced coffee), and well known for its stimulant properties.



roasted coffee beans

Roasting beans by a dry method at high temperature enhances the coffee's flavor and aroma.

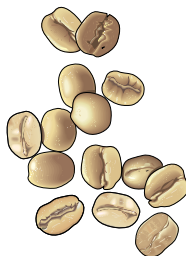

green coffee beans

The green beans remain fresh for many years but the roasted beans quickly lose their flavor.

herbal teas

Infusions made with aromatic dried herbs or plants, usually considered to have calming, digestive, tonic or curative properties.



linden

Tree whose dried leaves and flowers can be made into herbal teas, considered to have calming, sedative and soothing properties.



chamomile

Herbal teas made from the flowers and leaves of this plant are considered to have digestive and calming properties.



verbena

Herbal teas made from this native European plant are believed to have digestive and sedative properties.

tea

Infusion made from the dried leaves of the tea tree; drunk hot or iced, it is the world's most popular beverage after water; it is sold in bags or loose.

**green tea**

This unfermented product is very popular in China, Japan and Muslim countries; it has a more bitter taste than black tea.

**black tea**

Made from tea leaves that are fermented and then dried, it represents more than 98% of the total worldwide production of tea.

**oolong tea**

Semifermented tea; it has a stronger flavor than green tea but is more delicate-tasting than black tea.

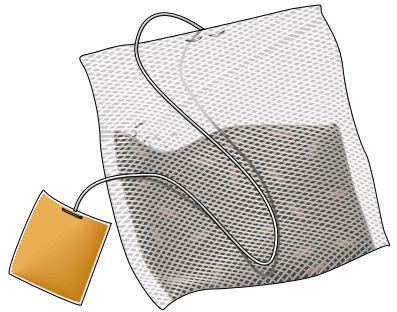
**tea bag**

Filled with ground leaves, it is often less flavorful than loose tea, which is composed of whole leaves.

chocolate

Smooth paste made with cocoa and sugar, extensively used in making candy and pastry and often eaten plain, as bars or squares.

**cocoa**

The key ingredient in chocolate; grinding the beans of the cacao tree produces chocolate liquor, which yields cocoa butter and cocoa powder.

**white chocolate**

Sweet and creamy, it is made from cocoa butter, sugar and condensed or powdered milk.

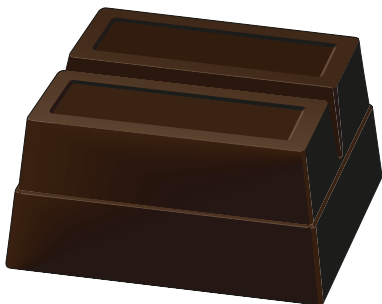
**dark chocolate**

Includes semisweet and bitter chocolate, which contain from 35% to 70% chocolate liquor; it is often used in cooking and is also eaten plain.

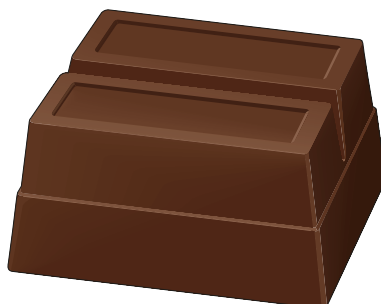
**milk chocolate**

Made with chocolate liquor and cocoa butter mixed with powdered milk; it cannot be used in cooking because the milk solids it contains burn when heated.

Sweet-tasting foodstuff derived from certain plants; the most common varieties of sugar come from sugarcane and sugar beets.



granulated sugar

The most commonly used sugar in cooking and baking; it is white, fully refined and composed of small crystals.



powdered sugar

White sugar in powdered form, containing about 3% corn or wheat starch, added to prevent caking; it is used mainly for icing and decorating.



brown sugar

Fine, only slightly refined sugar crystals that still contain molasses; it has a stronger taste than white sugar.



rock candy

White or brown sugar in very large crystal form; it is used especially to sweeten fruits in brandy.



honey

Substance made by bees from flower nectar; its color and flavor vary depending on the nectar's origin.



molasses

Thick liquid residue from the process of converting sugarcane into sugar; it is used to make rum, candy, soft cookies and pies.



corn syrup

Thick sweet syrup used extensively in making candy and pastry.



maple syrup

Produced by reducing sugar maple sap; it is used to make various desserts and to accompany pancakes, poach eggs and glaze ham.

fats and oils

Animal or vegetable fatty acids in solid or liquid form generally used to cook, flavor, thicken or preserve foods.

**sunflower-seed oil**

This delicately flavored oil is the main ingredient in margarine and dressings; it is also used for frying sweet foods.

**corn oil**

Has relatively little flavor or odor; one of the most ubiquitous oils, used for cooking, frying and seasoning foods.

**peanut oil**

Heat-resistant, mild-tasting oil equally well suited to frying and to dressing salads.

**olive oil**

This extract derived from olive pulp is essential to Mediterranean cooking, both for preparing and seasoning recipes.

**sesame oil**

Very popular in Asian cooking and characterized by its rich delicate toasted-nut flavor; it is not well suited to high temperatures.

**margarine**

Fatty acid used as a substitute for butter; those made with vegetable oil contain no cholesterol.

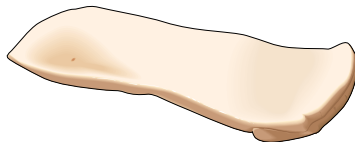
**lard**

Pork fat; fatback is rendered into shortening whereas side pork (fat streaked with lean) provides lardons and bacon.

**shortening**

Substance produced by rendering pork fat; it is used for the lengthy cooking of certain ragouts, and for frying and for making pastry.

Foods produced by processing fresh milk; they are used daily in Western countries, where they are known for their high calcium content.

**yogurt**

Semisolid substance produced by milk fermentation and the action of bacterial cultures; it can be eaten as is or cooked.

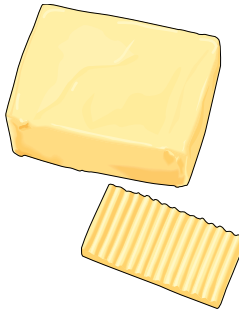
**butter**

Fatty rich substance produced by churning cream; it is used in cooking or is added to various recipes for sauces, pastries and creams.

**ghee**

Clarified butter originating in Asia and traditionally made from buffalo milk; it is very popular in India and in Arab countries.

cream

This product is obtained by skimming milk and is classified according to its milk fat content; it is used extensively in cooking, as is or whipped.

**whipping cream**

With a minimum 30% milk fat content, this is the richest cream; it is often whipped and used to make and decorate various desserts, such as cream puffs.

**sour cream**

Has a thick and creamy consistency and is obtained by fermentation and bacterial action; it can be used to flavor or garnish recipes.

dairy products

milk

Highly nutritious white liquid secreted by some domesticated female mammals and consumed as food; used alone, the word refers to cow's milk.

**homogenized milk**

Milk processed so the fat particles remain suspended instead of rising to the surface; varieties include whole, partially skimmed or skim.

**goat's milk**

Whiter and stronger-lasting than cow's milk, it is also easier to digest.

**evaporated milk**

Milk from which a significant percentage of the water has been evaporated; it has a high milk fat content and is used primarily for making desserts.

**powdered milk**

Dehydrated milk that can be stored for one year without refrigeration if the container remains unopened.

**buttermilk**

Tangy liquid that separates from cream during churning; today, commercial buttermilk is made by adding bacterial culture to milk.

goat's-milk cheeses

Cheeses made from goat's milk, which is sometimes mixed with cow's milk; these medium-strong cheeses have a smooth texture and a high water content.

**Chèvre cheese**

Fresh rindless cheese that has a tangy, mild taste; it is sometimes flavored with herbs.

**Crottin de Chavignol**

Soft French cheese with a rind that is covered in mold; it is eaten fresh or dried and, as it dries, its flavor becomes more pronounced.

fresh cheeses

Nonripened cheeses that contain up to 80% water; they are smooth and mild or slightly tangy; they spoil quickly.

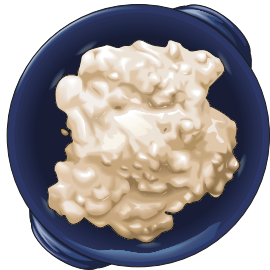
**cottage cheese**

Low in fat and grainy in texture; it works well as a spread or can be added to salads, desserts and sauces.

**mozzarella**

This native Italian cheese has a rubbery texture and is firmer than other cheeses; it is the garnish of choice for pizza.

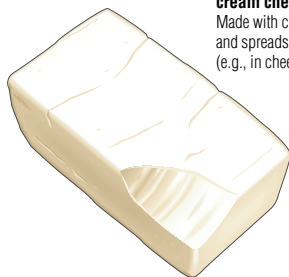
**cream cheese**

Made with cream, which is sometimes mixed with milk; it is smooth and spreads easily, and is used as a spread or as a dessert ingredient (e.g., in cheesecake).

**ricotta**

Granular cheese with a smooth moist rind; it is used in Italian cooking, primarily for stuffed foods and desserts.

dairy products

pressed cheeses

Ripened cheeses that are also cooked and pressed and contain less than 35% moisture; they usually have a firm compact texture and a hard rind.

**Romano**

Native to Rome, this dry granular cheese is made from cow, ewe or goat's milk or a mixture of all three; it is mostly used in grated form.

Gruyère

Swiss cheese with small holes called "eyes" and a medium-sweet taste; extensively used in cooking, either as is, grated or melted.

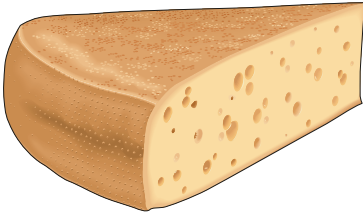
**Jarlsberg**

Norwegian cheese with large holes that has a characteristic nutty taste.

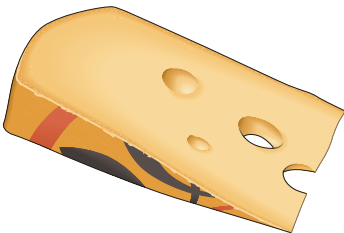
**Emmenthal**

Characterized by large holes, this mild Swiss cheese is very popular in fondues and au gratin dishes.

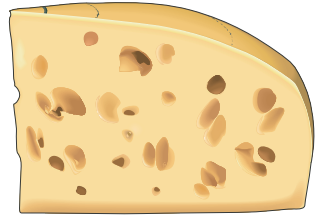
**Raclette**

Cheese specifically made to be used in a traditional eponymous dish that originated in the Valais region of Switzerland.

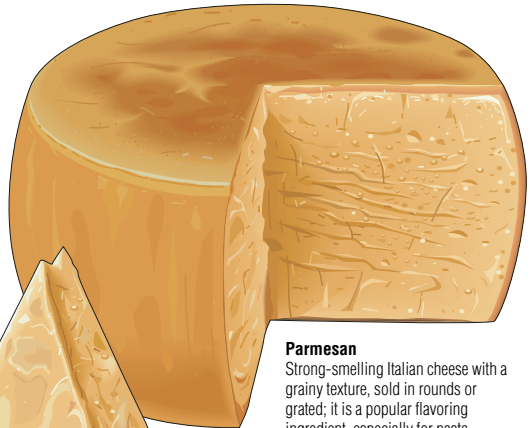
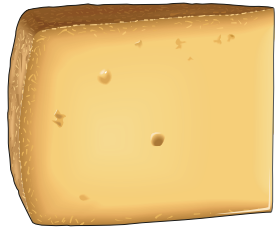
**Parmesan**

Strong-smelling Italian cheese with a grainy texture, sold in rounds or grated; it is a popular flavoring ingredient, especially for pasta dishes.

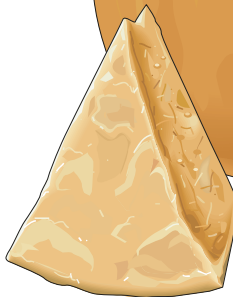

blue-veined cheeses

Also called "blue cheese", it usually has a crumbly texture, is veined with mold and has a pungent peppery taste.

**Gorgonzola**

Native to Italy and recognizable by its textured gray rind, spotted with red.

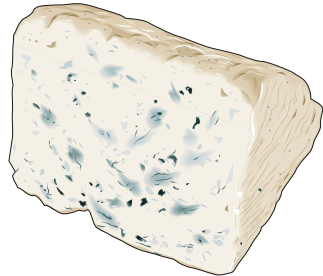
**Danish Blue**

Native to Denmark, it has a pungent flavor, a creamy texture and a milk fat content of up to 60%.

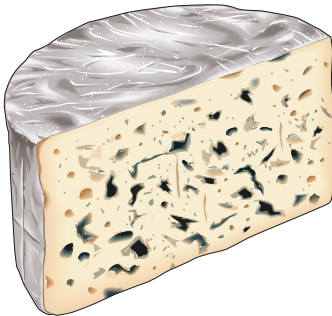
**Roquefort**

The best-known blue cheese, originally from Roquefort, France; it is made from ewe's milk and goes well with pears, cream and butter.

**Stilton**

English cheese with a firm but creamy texture; it is often served with crackers and port.

dairy products

soft cheeses

Ripened but neither pressed nor cooked, these cheeses have a soft, creamy texture and a somewhat velvety rind, which is often edible.

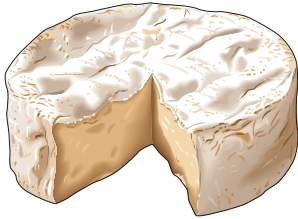
**Camembert**

Soft and easy to spread, France's most famous cheese is smaller and slightly firmer than Brie.

Coulommiers

Native to the area around Paris, it is similar to Brie but smaller; it contains from 45% to 50% milk fat.

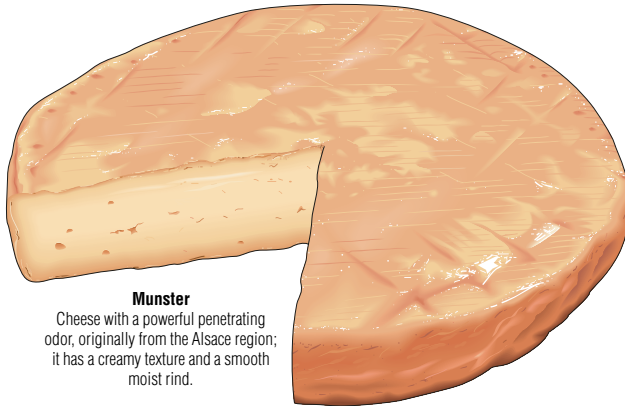
**Munster**

Cheese with a powerful penetrating odor, originally from the Alsace region; it has a creamy texture and a smooth moist rind.

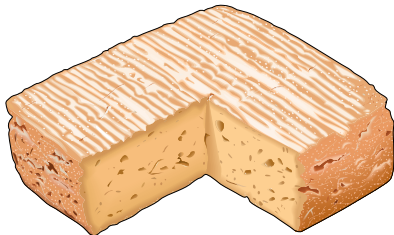
**Pont-l'Évêque**

Somewhat soft cheese with a pronounced odor; its name derives from the town in Normandy where it is made.

Brie

Native to Brie, near Paris, it is one of the best-known French cheeses; among its many varieties is the one from Meaux.

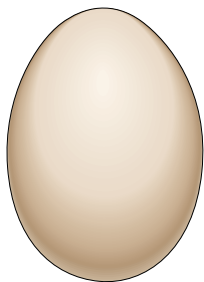

Foodstuff that female fowl, especially hens, produce by laying; there are many ways of preparing them: e.g., soft-boiled, scrambled and in omelettes.

**duck egg**

Prized in Asia for its taste, stronger than a chicken egg's; it must be boiled for at least 15 minutes to destroy harmful bacteria.

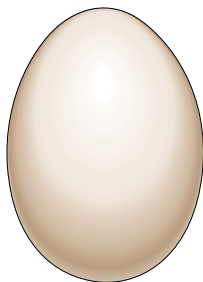
**hen egg**

By far the most commonly eaten, it is cooked as is or added to recipes; used alone, the word "egg" refers to a hen's egg.

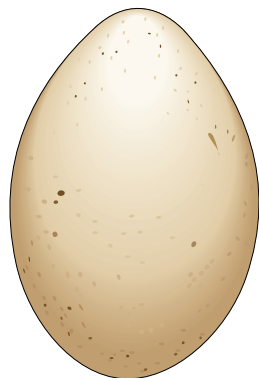
**goose egg**

These relatively large eggs weigh between 9 and 10.5 lbs; they are rarely found for sale.

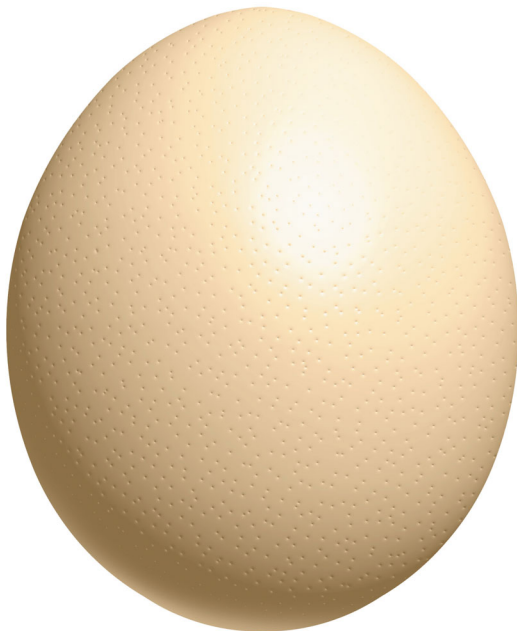
**quail egg**

Very popular in China and Japan, it is usually eaten hard-boiled, often as an appetizer; it also has decorative uses.

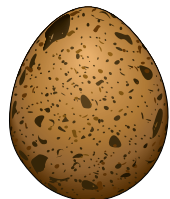
**ostrich egg**

The largest of all eggs, it can weigh up to 5 lbs; one ostrich egg makes an omelette large enough to feed 10 people.

pheasant egg

Rounder and smaller than a chicken egg, it is not readily available; it is mostly eaten hard-boiled, in salads or aspics.

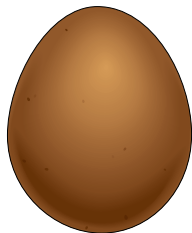

variety meat

Edible parts of slaughter animals, apart from the meat.

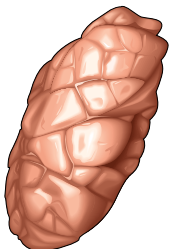

sweetbreads

Designates the tender, delicately flavored thymus gland of calves, lambs and kids; veal sweetbreads are especially prized.



heart

Cooked in ragouts and casseroles, it can also be sautéed, roasted, braised or simmered; veal, lamb and chicken heart are the most popular.



liver

People eat the liver of slaughter animals, poultry, game and some fish (cod); it has a high iron content.

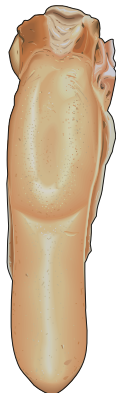

tongue

Covered with a thick skin that lifts off easily once cooked; calf tongue is the most tender.

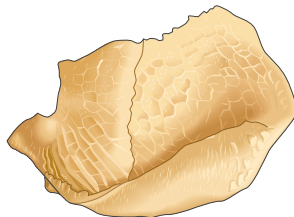

tripe

Ruminants' stomach lining, made ready for cooking; the main ingredient in many regional dishes, the best known being tripes à la mode de Caen.

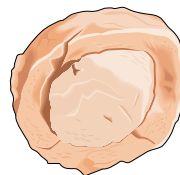

marrow

Soft fatty tissue found in the centre of bones; it is served mainly with roast beef and cardons and can also be used to add flavor to soups.

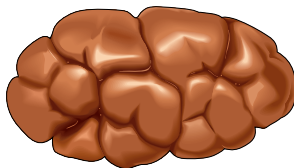

kidney

Young slaughter animals such as calves tend to have more tender kidneys; there is an unpleasant aftertaste if they are not prepared carefully.

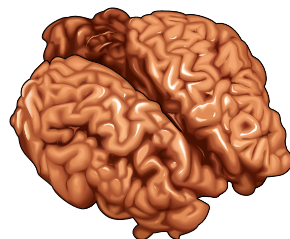

brains

Lamb, sheep and veal brains are the most prized, served in salads, au gratin, in croquettes, stuffings and sauces.

Wild animals that can legally be hunted and eaten as food; includes large and small game animals and game birds.



quail

Roasted, braised, broiled or cooked in a casserole, this small bird is a prized delicacy; it is delicious cooked with grapes.

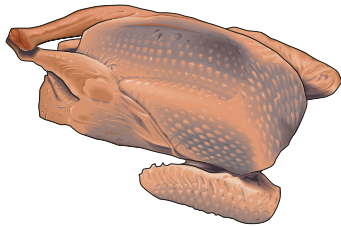

pigeon

Eaten since ancient times, pigeon is broiled, sautéed or roasted, or braised when the bird is mature; it is traditionally served with green peas.

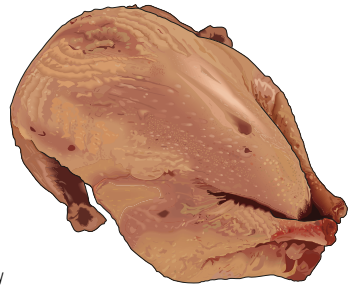

pheasant

Young pheasant are often broiled and served with a moist stuffing; as they age, they become dry and less tender and so are usually made into terrine or pâté.



rabbit

Wild rabbit has a more pronounced flavor than domesticated rabbit, which tastes like chicken; it is often prepared with a mustard sauce.



hare

The dark meat has a stronger flavor than rabbit meat. Young hares can be roasted or sautéed; older ones are marinated, then jugged or made into terrine or pâté.

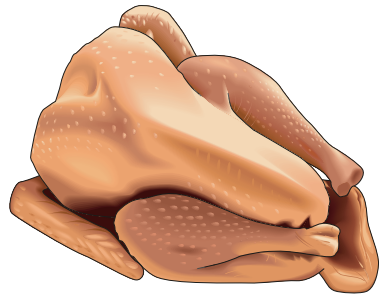

guinea fowl

The same size as a small chicken, it is more flavorful when young and weighs less than 2 lbs; its flesh is slightly gamey.

poultry

Term that refers to barnyard fowl, most of which have been domesticated for centuries and are now mass-produced.

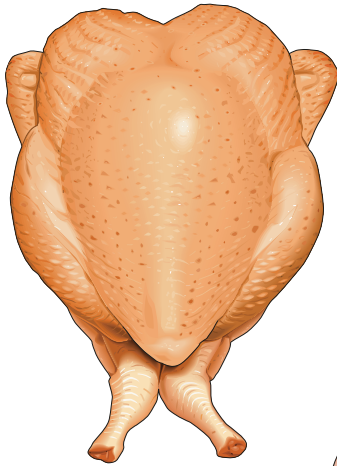
**capon**

Young rooster, castrated and fattened for slaughter; it grows to twice the size of a chicken yet has tender juicy meat.

chicken

The offspring of a hen, from 4 to 12 months old; it is cheap, tasty and can be prepared in numerous ways, thus it is the most popular type of poultry.

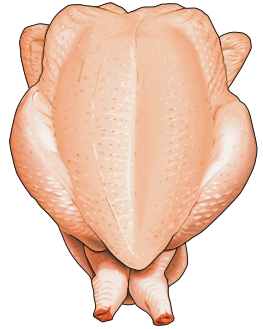
**turkey**

Prepared like chicken although its meat is drier; in North America, turkey with stuffing is the traditional Thanksgiving and Christmas meal.

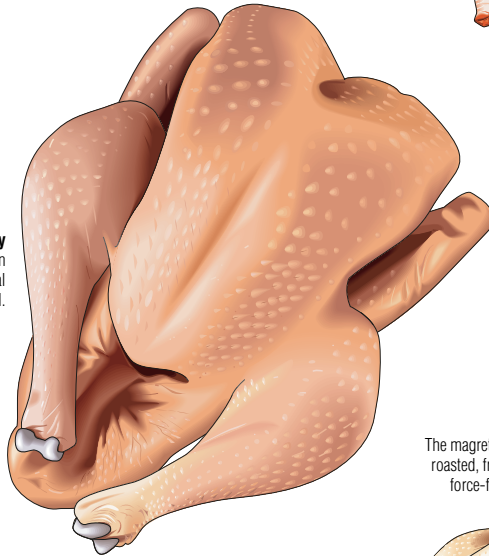
**goose**

Often force-fed to produce foie gras, it is delicious stuffed or served with a fruit sauce; goose stuffed with chestnuts is a classic European dish.

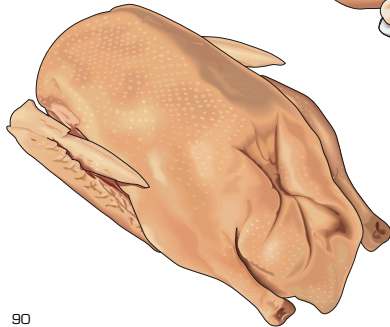
**duck**

The magret, or breast meat, can be roasted, fried or smoked; they are force-fed to produce foie gras.

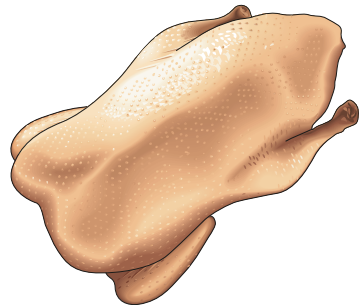

Foodstuff made from the meat (usually pork) or offal of various animals; among the many different varieties, some can be consumed as is, some are cooked.

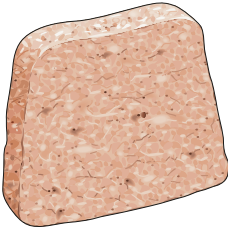
**rillettes**

Often made with pork or goose meat and cooked in fat until the meat disintegrates; they are always served cold.

**foie gras**

Goose or duck liver, abnormally enlarged by force-feeding; considered a gourmet item, it is sold raw or ready to eat.

**prosciutto**

Raw dried ham native to the Parma region of Italy; it is mostly eaten thinly sliced and served with melon or fresh figs.

cooked ham

Salt-cured and cooked pork meat, usually served thinly sliced; it is eaten hot or cold, especially in sandwiches, and on croque-monsieurs and canapés.

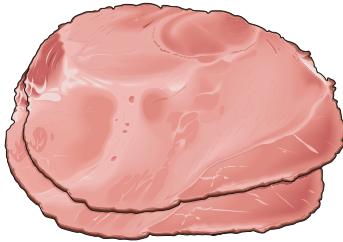
**pancetta**

Rolled Italian bacon, sometimes spiced; it is an essential ingredient in pasta alla carbonara and also flavors sauces, soups and meat dishes.

American bacon

Salted and smoked side pork, cut into thin slices; in North America, it is traditionally served with eggs, for breakfast.

**Canadian bacon**

Piece of salted, usually smoked, meat from the pork loin; it goes well with eggs and in dishes such as quiches and omelets.

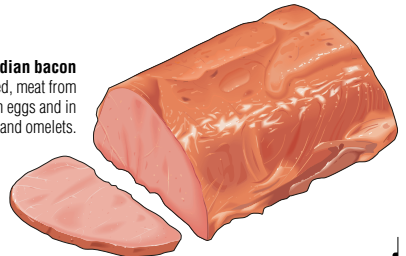



pepperoni

This dry, somewhat spicy Italian sausage is a favorite pizza topping; diced, it is added to certain dishes to give them more flavor.



chorizo

Semidry Spanish sausage seasoned with red chiles, available in several versions that vary in spiciness; it is often added to paella.

kielbasa sausage

Native to Poland, it is made with coarsely ground pork and beef, seasoned with garlic and spices.



mortadella

Fat Italian sausage made with meat and fat and flavored with peppercorns and pistachios.

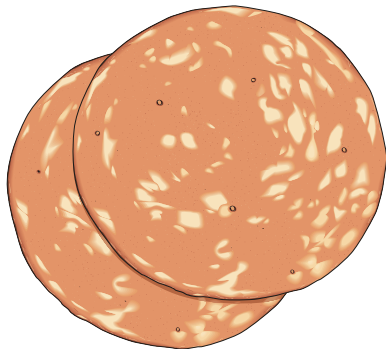

Genoa salami

Dry Italian sausage made with a mixture of pork, veal and fat; the thin slices are often served as an hors d'oeuvre.

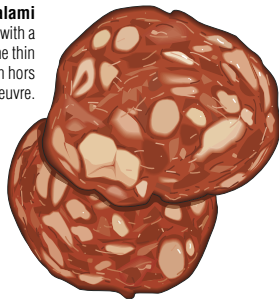

German salami

Made with finely ground beef and pork, it is usually served sliced, as an hors d'oeuvre, but also on pizza and canapés and in sandwiches.

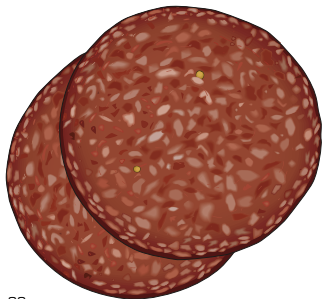

**chipolata sausage**

Raw pork, or pork and beef, sausage characteristically flavored with cloves; it is often grilled or fried.

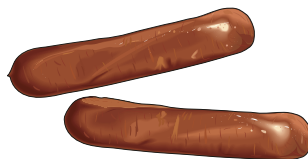
**merguez sausage**

Small, highly spiced sausage made with lamb, beef or mutton; popular in North Africa and Spain, it is usually eaten fried or grilled.

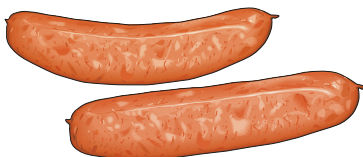
**Toulouse sausage**

Raw sausage, native to France, made with coarsely ground pork and pepper; often added to cassoulet.

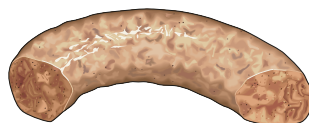
**andouillette**

Cooked sausage made from pig or calf intestines; it can be grilled or fried and served with mustard.

**frankfurter**

Smoked precooked sausage that is native to Germany and made from a pastelike pork mixture; among its many versions is the American hot dog.

**blood sausage**

The main ingredients in blood pudding are blood and suet (from pigs or other animals) packed into a casing; white pudding is made from white meat and milk.

meat

Flesh of slaughter animals, consumed as food; a distinction is usually made between red meat, such as beef and lamb, and white meat, such as veal and pork.

cuts of beef

Bovine carcasses are divided into quarters, then into pieces of meat that are ready to prepare.

**ground beef**

Made from various parts of the steer; when lean and taken from the tenderloin, it is the basis for steak tartare.

**rib roast**

Piece of meat intended for roasting, taken from the animal's rib section; this tender and tasty cut is one of the most popular kinds of roast beef.

**steak**

Strip of meat that can be grilled or sautéed; in general, the most tender steaks, loin, sirloin and rib, come from the central section of the carcass.

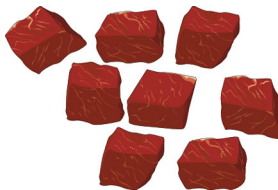
**beef cubes**

Their tenderness varies, depending on the section from which they were cut; they are mainly used to make brochettes or ragouts, such as boeuf bourguignon.

**shank**

Comes from a section of the front or hind leg of a steer; somewhat tough, it is primarily used in stews.

**tenderloin roast**

Taken from the back, along the spine, it is prized for its tenderness and is excellent when grilled; tournedos and châteaubriand come from it.

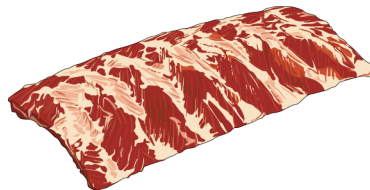
**back ribs**

They comprise sections of rib taken from the back and the attached muscles; they are delicious with a sweet-and-sour sauce.

cuts of veal

Pieces taken from a cow's offspring, slaughtered before it reaches one year; veal is a tender delicate meat that ranges in color from whitish to pink.

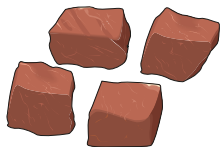
**veal cubes**

Their tenderness varies, depending on the section of the calf they come from; they are used mainly to make brochettes or ragouts.

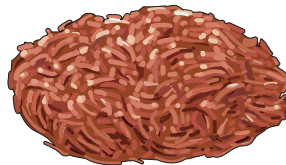
**ground veal**

Made from various parts of the calf, its flavor is less pronounced than that of ground beef.

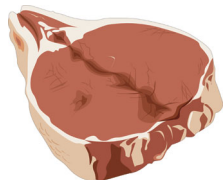
**chop**

Piece composed of a bone from the rib section and the attached muscles, generally eaten grilled.

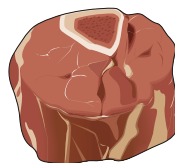
**shank**

Comes from a section of the front or hind leg of a calf; when sliced, it is primarily used to make the Italian dish called osso bucco.

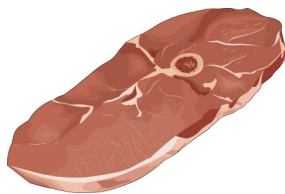
**steak**

Strip of meat that can be grilled or sautéed; in general, the most tender steaks, loin, sirloin and rib, come from the central section of the carcass.

roast
Piece of meat intended for roasting, of variable tenderness; since the meat is lean, it is advisable to bard the roast with fat before cooking it.

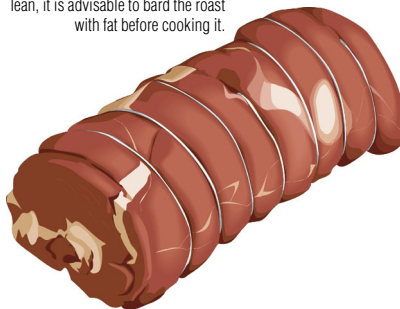

cuts of lamb

Highly prized in the Middle East, lamb comes from an animal less than one year old; milk-fed lamb has a more delicate flavor than regular lamb.

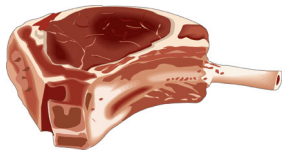
**chop**

Piece composed of a bone from the rib section and the attached muscles, generally eaten grilled.

**ground lamb**

Made from various parts of the lamb, it is used especially to make Greek moussaka.

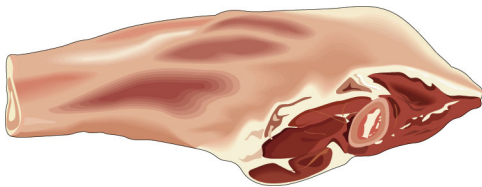
**shank**

Section of the front or hind leg of a lamb.

**lamb cubes**

Their tenderness varies, depending on the section of the lamb they come from; they are used mainly to make brochettes or ragouts.

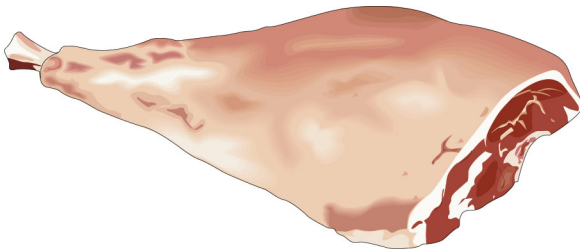
**roast**

Piece of meat intended for roasting; the gigot, taken from the hind section of the carcass, is the best-known cut and is a traditional Easter dish in some countries.

cuts of pork

Pieces taken from a pig carcass, the most tender of which come from the loin (back); the side (belly), leg (butt) and shoulder are the least tender parts.

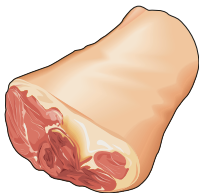
**hock**

Also called "shank end", it comes from the lower section of the pig's front or hind leg; it is used to make the traditional pork hock stew.

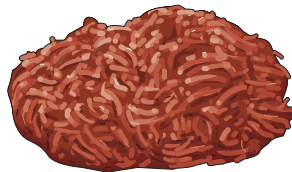
**ground pork**

It is made from various parts of the pig and is very tender; it is used especially to make stuffed vegetables and meatloids.

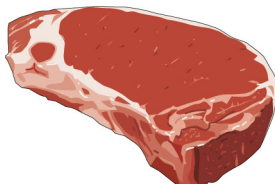
**loin chop**

Piece composed of a bone from the rib section and the attached muscles; some, like the butterfly chop, are sold boned.

**spare ribs**

They comprise sections of rib taken from the back and the attached muscles; North American-style Chinese cooking usually serves them with sweet-and-sour sauce.

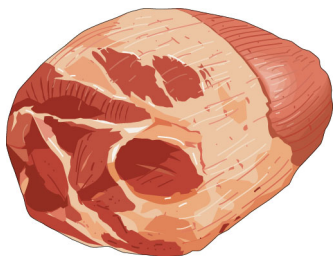
**smoked ham**

Taken from the pig's legs, this cut is preserved by smoking; it is sold as is, boned or sliced and can be prepared in numerous ways.

**roast**

Piece of meat intended for roasting, usually from the loin, leg or shoulder.

mollusks

Usually marine-dwelling, soft-bodied invertebrates; some have shells and are sold live.

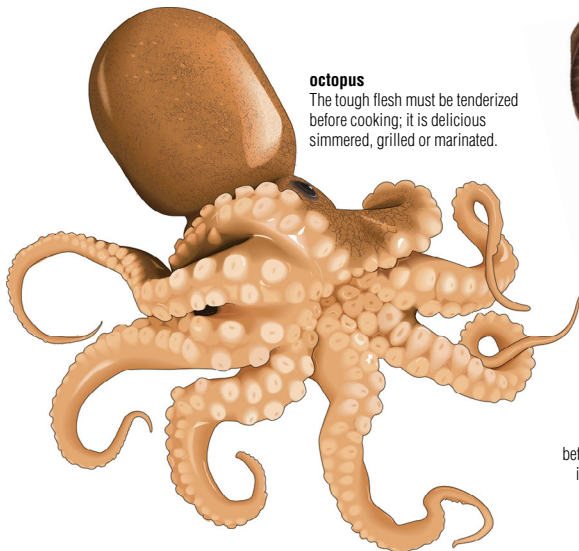
**octopus**

The tough flesh must be tenderized before cooking; it is delicious simmered, grilled or marinated.

**cuttlefish**

The very firm flesh must be pounded before cooking and is delicious stuffed; the ink, or sepia, can also be used to color certain recipes.

squid

The edible parts are the tentacles, the body pouch and the ink; often grilled or fried, the lean flesh can occasionally be rubbery.

**great scallop**

Related to the scallop, the delicately flavored flesh is prized by Europeans; the shells are resistant to heat and are often used as cooking and serving dishes.

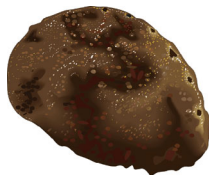
**abalone**

The muscle, also called the "foot", is delicious raw or cooked; it must be pounded before cooking.

**hard-shell clam**

Mollusk with a very hard shell whose flesh can be eaten raw or cooked; they are used to make chowder, a popular New England recipe.

**scallop**

The main edible part is the nut (the muscle that opens and shuts the shells) and sometimes the coral (the orange part); excellent raw or cooked, it can be prepared in numerous ways.

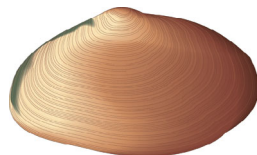
**soft shell clam**

Primarily harvested in the Atlantic, this large soft mollusk of the clam family can replace the latter in recipes.

**snail**

Snails are often sold canned, frozen or ready-cooked; served with garlic butter, they constitute a classic appetizer.

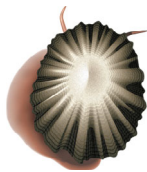
**limpet**

It has a single shell and is eaten raw with lemon juice or vinegar, or grilled, with butter.

**common periwinkle**

Its flesh resembles the snail's, which it can replace in most recipes; whether eaten hot or cold, it is always cooked first.

**clam**

Related to the hard-shell clam, it is as tasty raw (with or without lemon juice) as it is cooked (in soups, or stuffed, like the blue mussel).

**cockle**

Generally designates the European variety, although others exist; it has a firmer texture and a more pronounced flavor than oysters and mussels.

**blue mussel**

Fresh mussels are usually poached in broth or steamed until they open; those that fail to open should be discarded.

**whelk**

Resembles a large periwinkle; the flesh will toughen if it is cooked too long and it is often eaten sprinkled with lemon juice.

**razor clam**

Elongated mollusk of the clam family, with a shell sharp enough to cut skin, hence its name.

**flat oyster**

Less common than the cupped oyster, with a completely flat lower shell; the belon variety is particularly prized.

**cupped Pacific oyster**

Juicy and meaty, with a well-developed lower shell; like all oysters, it is often eaten raw, either plain or with lemon juice.

crustaceans

Aquatic invertebrates having a carapace over their bodies; they are sold live, frozen (raw or cooked) or canned.

**lobster**

To ensure maximum freshness, the lobster should be cooked live, by plunging it into boiling liquid.

**shrimp**

Delicious hot or cold; although many prefer them deveined, the intestine (the dark vein running along the back) is edible.

**crab**

Sometimes sold live and cooked like the lobster, its lean stringy flesh, its liver and the creamy substance under the shell can all be eaten.

**crayfish**

Small freshwater crustacean usually prepared like lobster; only the tail is eaten and its pinkish-white flesh is lean and delicate.

**scampi**

Rarely sold live, it resembles a small lobster but has more delicate flesh; it is often served with garlic butter.

**spiny lobster**

Spiny-shelled crustacean whose flesh is slightly less flavorful than the lobster's; the tail is the only part that is commonly found for sale, either raw or cooked.

Fish with skeletons made of cartilage rather than bones; their flesh usually contains no bones.

skate

Its pinkish or whitish boneless flesh must be cooked until it is no longer viscous or gelatinous; the main edible parts are the wings (pectoral fins).



larger spotted dogfish

Shark of the Mediterranean and Atlantic; it tastes best if cooked when very fresh and served with a flavorful sauce.

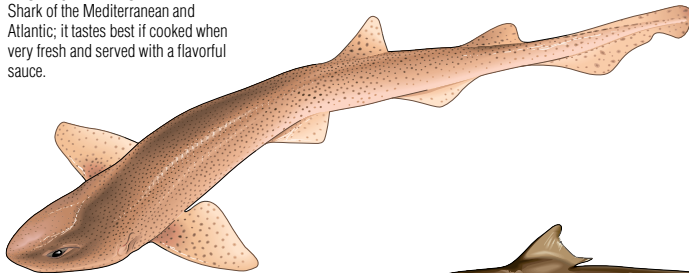

smooth hound

Shark of the Mediterranean, Atlantic and Pacific; its white flesh has a faint smell of ammonia that disappears with cooking.

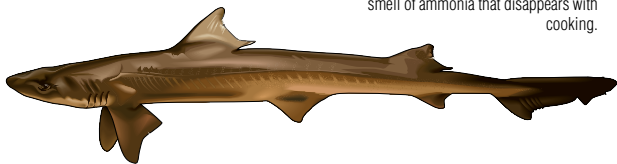

sturgeon

This freshwater or saltwater fish of imposing size is prized for its firm flesh and its eggs, which constitute the true caviar.

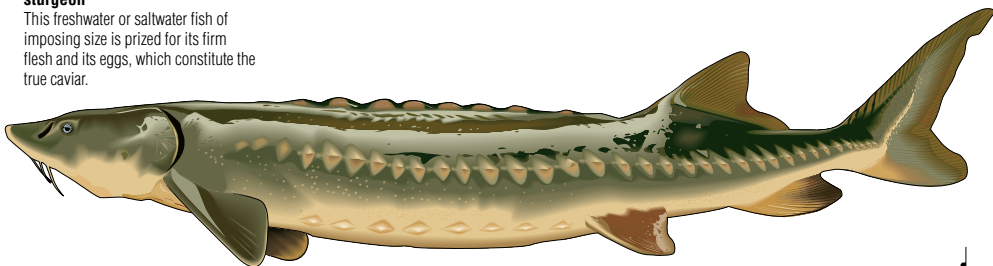

bony fishes

Fish with smooth flat scales and a rigid skeleton; the various species make up the largest group of fish.

**sardine**

Related to the herring, it is often canned (in oil, tomato sauce or white wine) and is eaten with bread, as is or with lemon juice.

**anchovy**

Very popular in Mediterranean countries, this highly perishable fish is often preserved in brine, oil or salt and sold in cans or jars.

**sea bream**

Its delicate lean white flesh can be prepared in many ways although the simplest are the best; it is delicious smoked, in sashimi or in ceviche.

**herring**

One of the world's most harvested species, it is sold fresh as well as canned, marinated, salted and smoked; it can replace mackerel in most recipes.

**goatfish**

In spite of its many bones, it is highly prized, especially in southern France, for its particularly delicate flavor.

**smelt**

The somewhat oily cucumber-scented flesh is the main part eaten, but the head, bones, tail and eggs are also considered edible; it is most often simply gutted and fried.

swordfish

The highly prized flesh becomes easier to digest if it is poached before being prepared; the tail and fins are also edible.

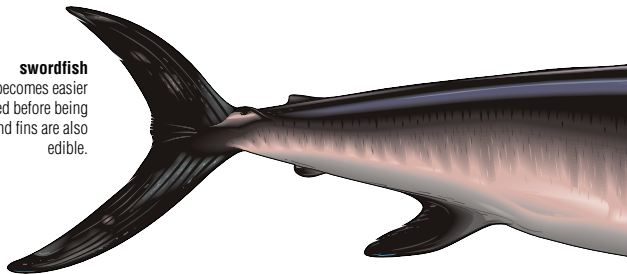



eel
Prized in Europe and Asia for its delicate firm oily flesh; its excess fat is removed when it is skinned.

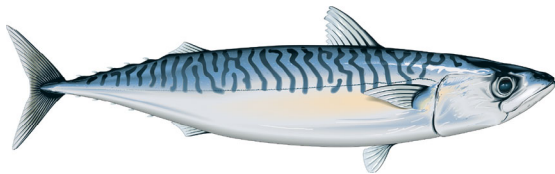

mackerel
Traditionally served with gooseberry chutney, its somewhat oily flesh spoils rapidly if not eaten promptly.

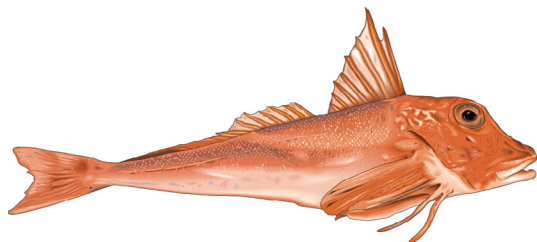

gurnard
Somewhat lean, it is often used in soups such as bouillabaisse and in fish stews; it is also excellent baked, poached, fried or smoked.



lamprey
The flavor of its oily boneless flesh is more delicate than the eel's; lamproie à la bordelaise is a famous French gourmet recipe.

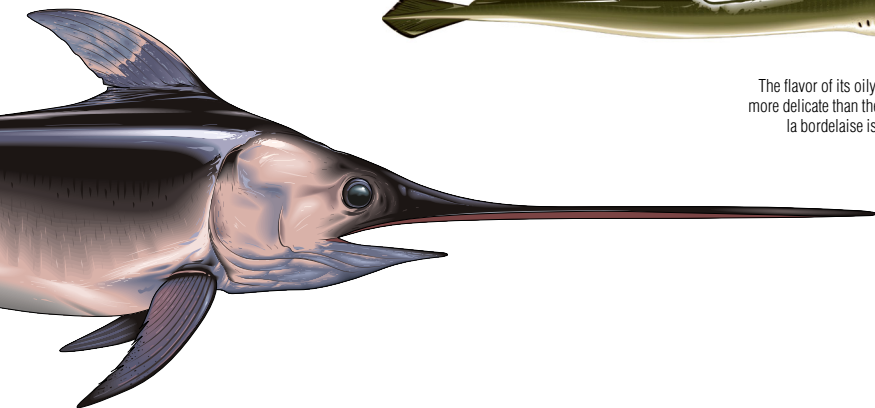

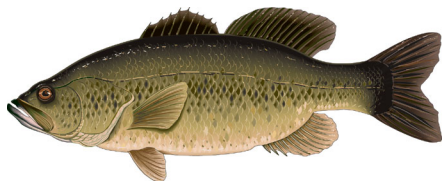

bass

Rarely found for sale, this sport fishing species has lean flaky flesh that is well suited to all cooking methods.



mullet

Excellent hot or cold, it is well suited to all cooking methods; its eggs are used to make *boutargue provençale* and the Greek *taramosalata* (a creamy spread).



pike

The flesh sometimes has a slightly muddy taste that disappears with soaking; because it has many bones, it is often made into *pâtés* or *quenelles*.



carp

Soaking in vinegar water will make the sometimes muddy taste of the wild varieties disappear; it is especially prized for its tongue and lips.



perch

Related to the pike perch, it is often poached, steamed or floured and fried in butter; its bony flesh has a delicate flavor.

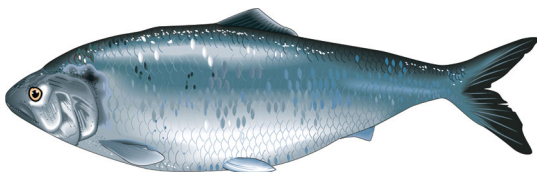

shad

Acidic ingredients such as sorrel and rhubarb are often used to prepare its somewhat oily, tender flesh; the bones of the female are more easily removed.

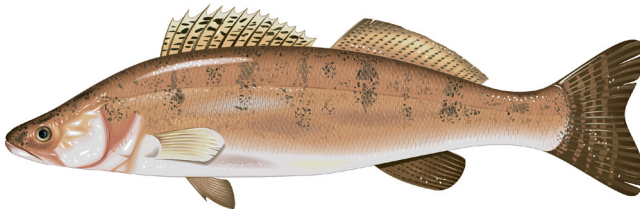
**pike perch**

Freshwater fish with a lean firm delicate flesh that can be cooked in many ways; whole and filleted, it is prepared like perch or pike.

bluefish

Very popular in the U.S., this lean fish is often grilled, braised or poached; it is prepared like mackerel.

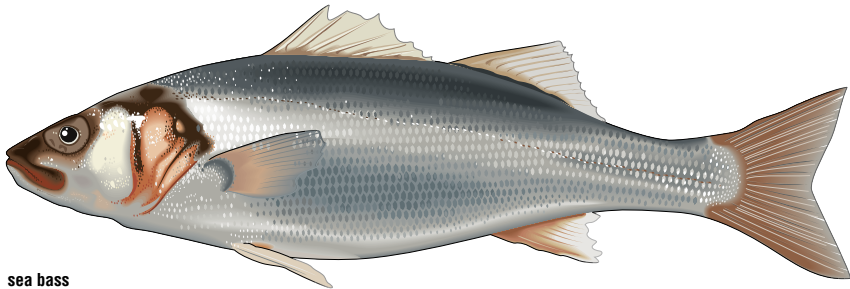
**sea bass**

Its firm lean flesh has few bones and withstands cooking well; it is best cooked simply, to avoid overpowering the delicate taste.

monkfish

Also called "angler fish", only its tail is eaten and the taste is said to be similar to lobster; it is delicious cold, served with a dressing.

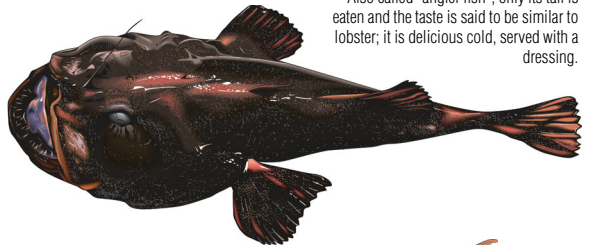
**tuna**

Often canned in oil or water, it is one of the main ingredients in the Italian dish vitello tonnato; it is also used to make salads, sushi and sashimi.

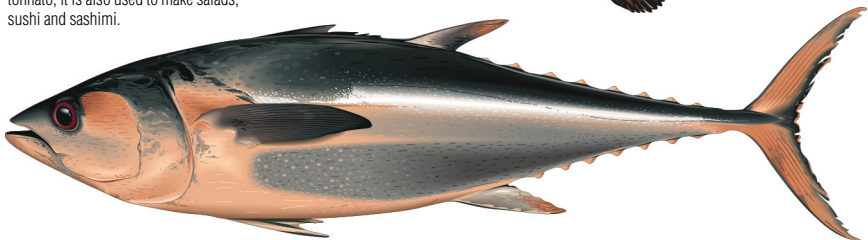

bony fishes

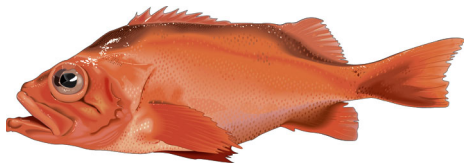
**redfish**

Excellent raw, cooked or smoked; if cooked in broth or grilled, it is best to leave the skin on to prevent its flaky flesh from falling apart.

**trout**

Freshwater fish with medium-oily delicate and fragrant flesh that is delicious smoked; rainbow trout is the species most often raised in captivity.

**whiting**

Its delicate flaky flesh is similar to cod's and is easy to digest; it is often wrapped in tinfoil or cooked in a flavored broth.

haddock

Related to cod but with flesh that is sweeter and more delicate; it is often smoked.

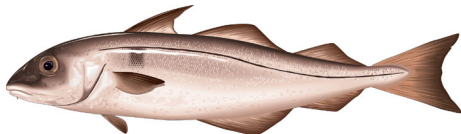
**brook trout**

Native to Canada, it resembles the trout and is greatly prized for its delicate flesh, which is best when simply prepared.

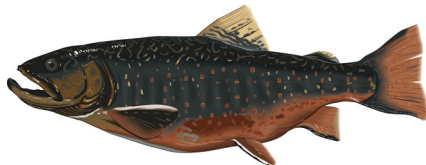
**black pollock**

Especially popular in England, it is also used in Canada to make surimi, a paste from which imitation seafood is made.

**Atlantic cod**

It is often dried or salted and its liver yields an oil that is rich in vitamin D; it is fished extensively off the Canadian and American coasts.

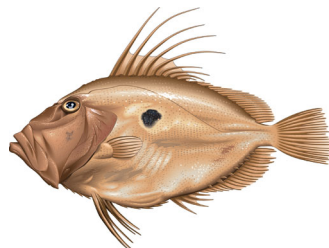
**John dory**

Usually prepared like sole or turbot, its medium-firm flesh contains gelatinous bones that make an excellent fish stock.

Pacific salmon

King salmon (or chinook) has the oiliest flesh and is greatly prized; the leaner and less oily varieties are often canned.

**Atlantic salmon**

The only species of salmon inhabiting the Atlantic; it is prized for its pink, somewhat oily and fragrant flesh and is sold fresh, frozen and smoked.

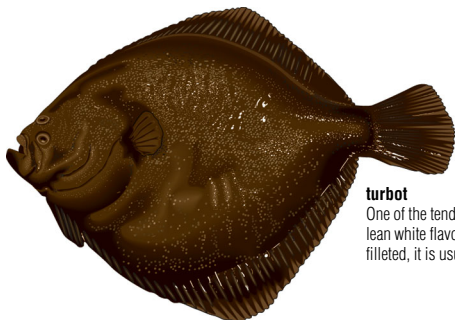
**turbot**

One of the tenderest saltwater fish, with lean white flavorful flesh; sold whole or filleted, it is usually poached or grilled.

**common plaice**

Because it has so many bones, it is often sold filleted and is one of the varieties used in fish-and-chips; it is found primarily off the European coast.

**halibut**

The largest of the flatfish family, it is commonly cooked in wine or served with anchovy butter; its lean flaky flesh has few bones.

**sole**

Often confused with plaice, it is only found in waters off the European coast; the most highly prized variety is the common or Dover sole.

packaging

Anything to do with the packing or wrapping of food, whether to sell, cook, freeze or preserve it.



pouch
A small bag.



freezer bag
Airtight bag used to freeze food.

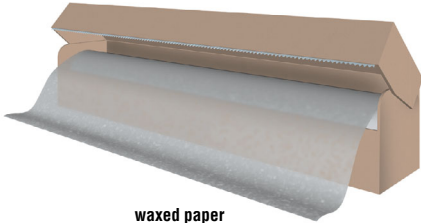

waxed paper
Waterproof paper treated with wax or paraffin that is somewhat heat resistant; it is used mainly to protect work surfaces while cooking.

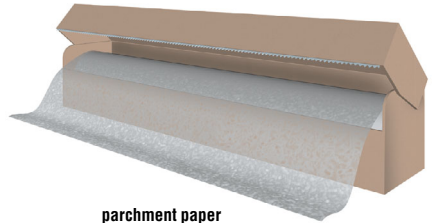

parchment paper
Greaseproof and heat-resistant paper; primarily used in baking and for cooking en papillote.

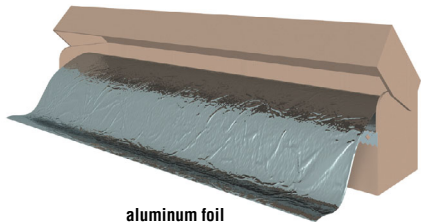

aluminum foil
Very thin sheet of aluminum used to wrap, cook, refrigerate or freeze food.

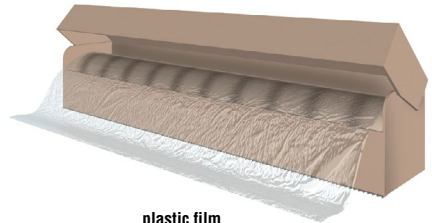

plastic film
Transparent adhesive sheet used to wrap food or cover containers.

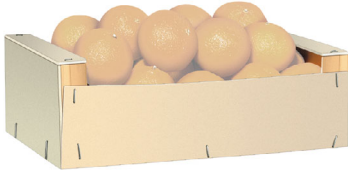
**small crate**

Small wooden or cardboard case usually designed for shipping and handling fruit.

**food tray**

Small molded receptacle, light and rigid, used to sell, freeze or reheat food.

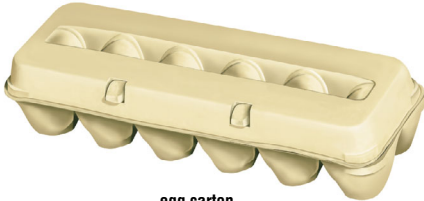
**egg carton**

Rigid receptacle, usually made of cardboard or plastic, composed of six or 12 cavities designed to hold eggs.

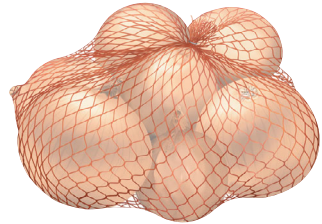
**mesh bag**

Bag made of netting that allows fruit and vegetables to breathe.

**canisters**

Airtight containers designed to contain dry goods.

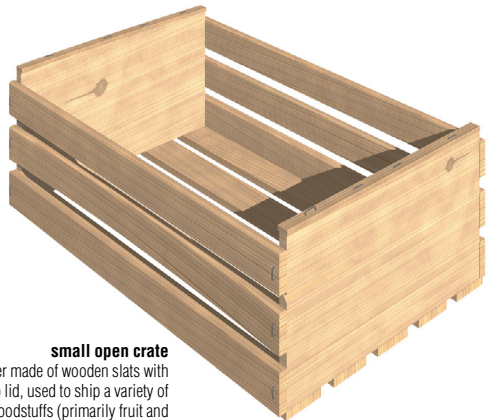
**small open crate**

Container made of wooden slats with no lid, used to ship a variety of foodstuffs (primarily fruit and vegetables).

packaging



tube

Flexible cylinder-shaped packaging with a flattened base containing a paste that is squeezed out by finger pressure.



package

A unit formed of foodstuffs or objects of a similar nature that are packaged together.



multipack

Multiple products packaged together to facilitate shipping and handling.

glass bottle

Narrow-necked, elongated receptacle containing drinks (mineral water, wine, etc.) or liquid foodstuffs such as sauces.



screw cap

Threaded stopper that can be screwed on the top of a bottle.



food can

Airtight metal container that holds cooked food.

cup
Vessel of various sizes used for selling prepared foodstuffs.



heat-sealed film

Sheet that can be sealed by heat, making a container airtight.

pull tab
Small metal strip that can be lifted with a fingernail and fingertip to open a can.

beverage can

Small cylindrical aluminum container filled with products such as beer and soft drinks.





milk/cream cup

Single-serving portion served with coffee.

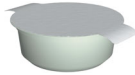

butter cup

Single-serving portions served with bread in restaurants.



cheese box

Small cylindrical container, generally made of wood or cardboard, containing a round of cheese wrapped in paper.



straw

A hollow tube used for sucking up a liquid.

gabletop

Top part of a carton closed by flaps, one end of which can turn into a pouring spout.

drink box

Small single-serving box in which juice can be kept for a long time.

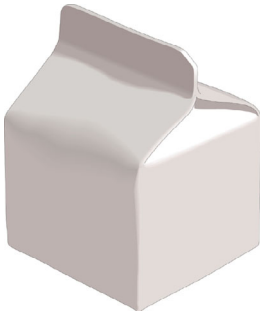

small carton

Small watertight container, usually filled with milk or cream; it comes in pint and half-pint sizes.



brick carton

Container in which milk, juice and other drinks can be kept for a long time.

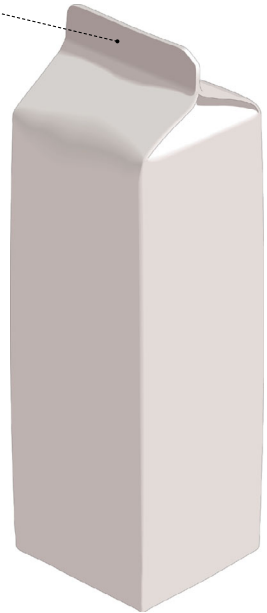

carton

Watertight container for the sale of liquid foodstuffs such as milk and juice; it comes in one- or two-quart sizes.

kitchen

Room where meals are prepared.

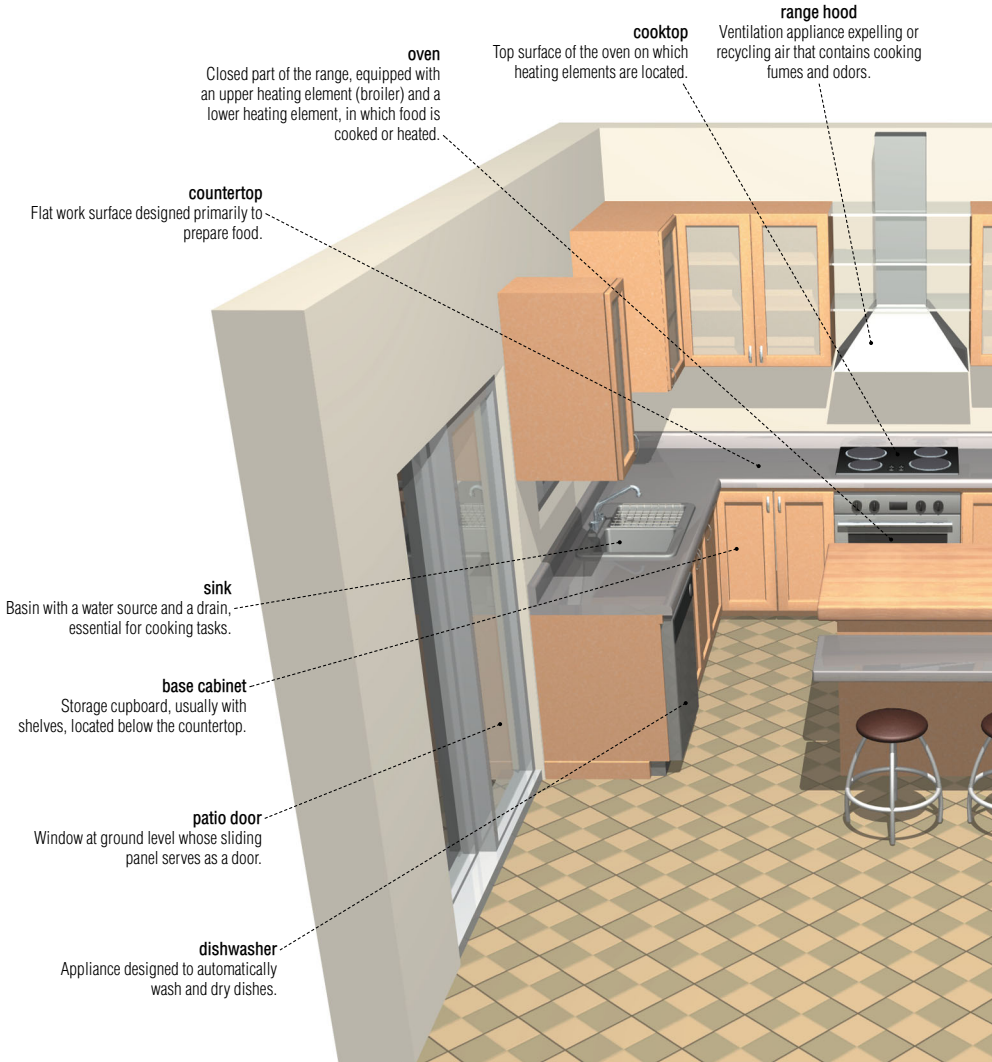

oven

Closed part of the range, equipped with an upper heating element (broiler) and a lower heating element, in which food is cooked or heated.

cooktop

Top surface of the oven on which heating elements are located.

range hood

Ventilation appliance expelling or recycling air that contains cooking fumes and odors.

countertop

Flat work surface designed primarily to prepare food.

sink

Basin with a water source and a drain, essential for cooking tasks.

base cabinet

Storage cupboard, usually with shelves, located below the countertop.

patio door

Window at ground level whose sliding panel serves as a door.

dishwasher

Appliance designed to automatically wash and dry dishes.

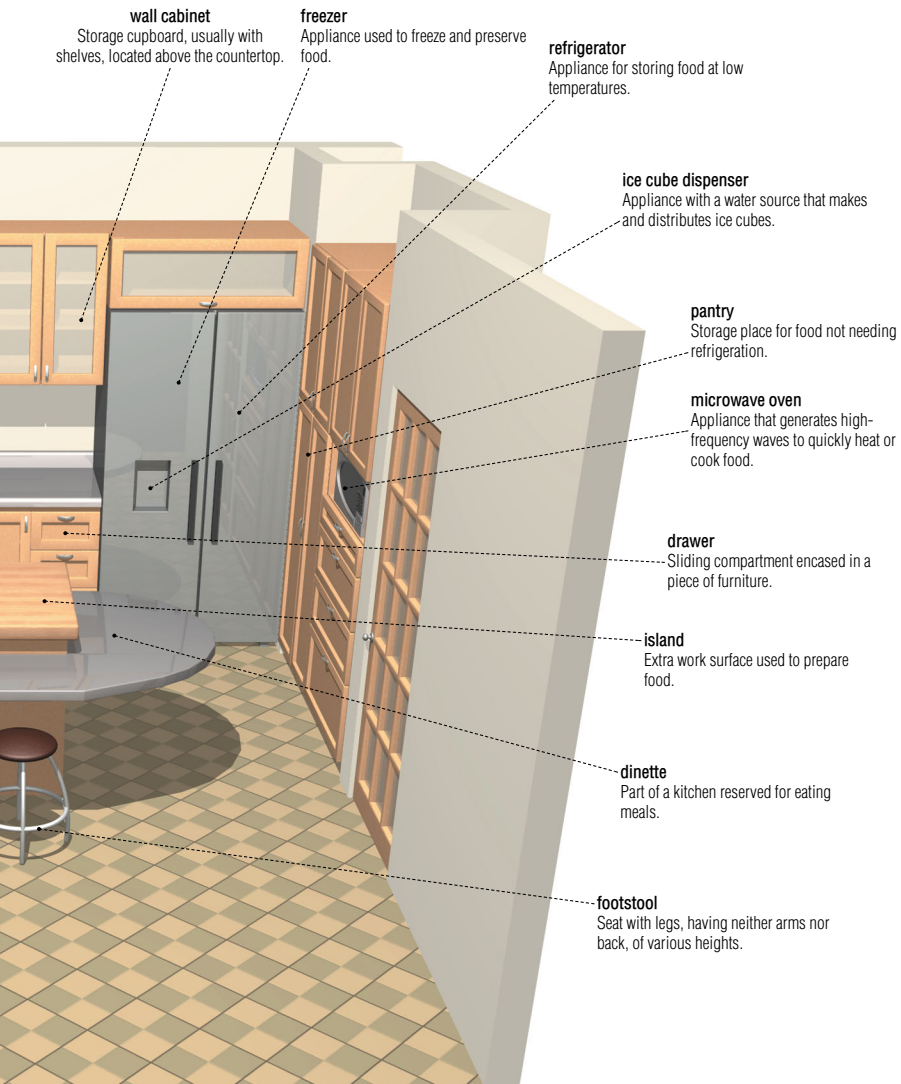

wall cabinet

Storage cupboard, usually with shelves, located above the countertop.

freezer

Appliance used to freeze and preserve food.

refrigerator

Appliance for storing food at low temperatures.

ice cube dispenser

Appliance with a water source that makes and distributes ice cubes.

pantry

Storage place for food not needing refrigeration.

microwave oven

Appliance that generates high-frequency waves to quickly heat or cook food.

drawer

Sliding compartment encased in a piece of furniture.

island

Extra work surface used to prepare food.

dinette

Part of a kitchen reserved for eating meals.

footstool

Seat with legs, having neither arms nor back, of various heights.

glassware

Drinking receptacles; some are used to measure volume for cooking.



liqueur glass

Very small stemmed glass used for drinking liqueurs with a high alcohol content.



port glass

Small rounded stemmed glass used to serve port and dessert wines.



brandy snifter

Short-stemmed glass whose pear shape allows the cognac to warm up, and whose narrow lip concentrates the aroma.



white wine glass

Somewhat narrow stemmed glass usually used for white wines.



Alsace glass

Glass with a long stem, usually green, used to serve Alsatian white wines.



sparkling wine glass

Stemmed glass, wider than it is tall, used to serve champagne and sparkling wines.



bordeaux glass

Tulip-shaped stemmed glass, mainly used for Bordeaux; tapering slightly at the top, it concentrates the aroma.



burgundy glass

Stemmed glass whose wide mouth ensures maximum oxygenation of the wine; it is used mainly for Burgundies.

**cocktail glass**

Conical stemmed glass used to serve certain cocktails; before serving, the rim of the glass can be frosted or decorated with fruit.

**champagne flute**

Tall and very thin stemmed glass used for champagne and sparkling wines; because the air bubbles break more slowly, the wine retains its effervescence longer.

**water goblet**

Large stemmed glass used to serve water at the table; taller and wider than wine glasses.

**highball glass**

Tall narrow straight glass used for serving liquor such as gin, often over ice or sometimes mixed with water, soda, etc.

**old-fashioned glass**

Wide short straight glass with a thick bottom primarily used for serving whiskey.

**beer mug**

Large cylindrical vessel with a handle used to serve beer; it is usually made of thick glass, ceramic or stoneware.

**small decanter**

Small carafe used in restaurants to serve wine.

**decanter**

Glass or crystal carafe with a wide base and a narrow neck used to serve water or wine.

dinnerware

Receptacles of various sizes, shapes and materials used to present food and for eating it.



demitasse
Small cup for serving coffee.



coffee mug
Large cup used to serve café au lait.

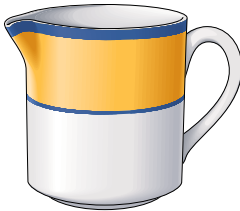

creamer
Small jug used to serve cream at the table.



cup
Cup, larger than the demitasse, used to serve tea.

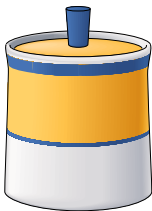

sugar bowl
Small pot used to serve sugar at the table.



teapot
Receptacle used for steeping and serving tea.

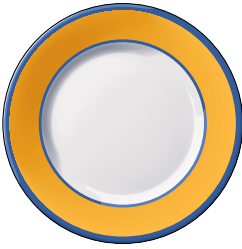

bread and butter plate
Small flat plate used to serve desserts.



soup bowl
Deep round container used to serve individual portions of soup.

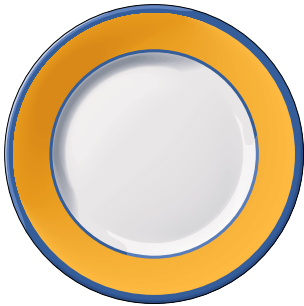

salad plate
Flat plate commonly used to serve salads or appetizers.



rim soup bowl
Shallower round container used to serve individual portions of soup.

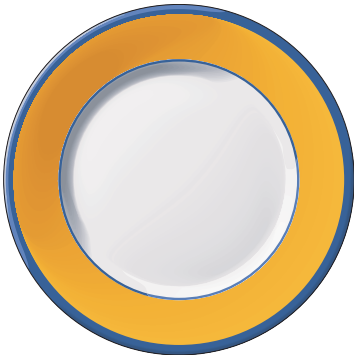

dinner plate
Large piece of flat or shallow dinnerware, usually containing individual portions of solid food.

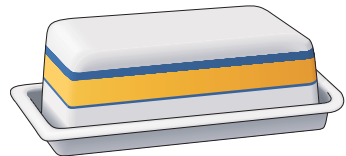

butter dish
Flat covered receptacle from which guests serve themselves butter.

platter

Large oval plate used to present and serve various solid foods, such as cuts of meat, roasts, grilled meat and omelettes.

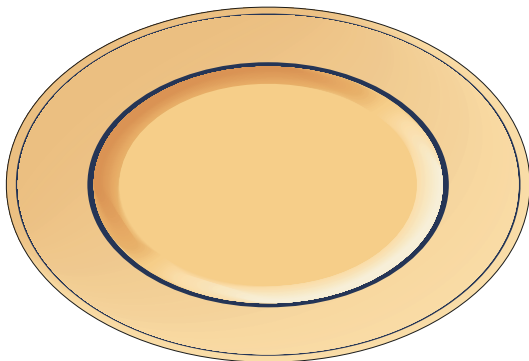

salt shaker

Small receptacle used to serve salt at the table, often paired with the pepper shaker.



pepper shaker

Small receptacle used to serve pepper at the table, often paired with the salt shaker.

fish platter

Large oval plate used to serve a whole cooked fish.

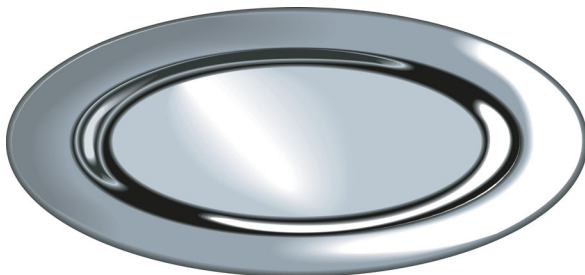

vegetable bowl

Large receptacle used to bring side vegetables to the table.

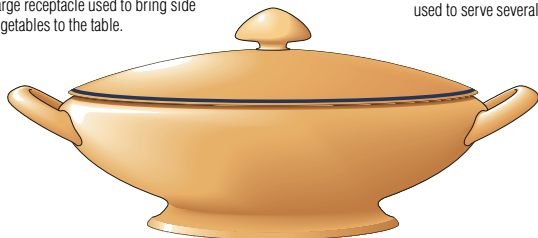

hors d'oeuvre dish

Serving platter divided into sections used to serve several complementary foods.



**water pitcher**

Receptacle with a handle and a spout used mainly to serve juice and water.

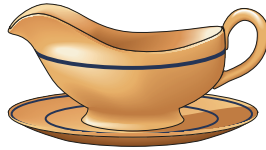
**gravy boat**

Receptacle used to serve sauces at the table.

**ramekin**

Small containers, suitable for oven and table, used to cook and serve individual portions.

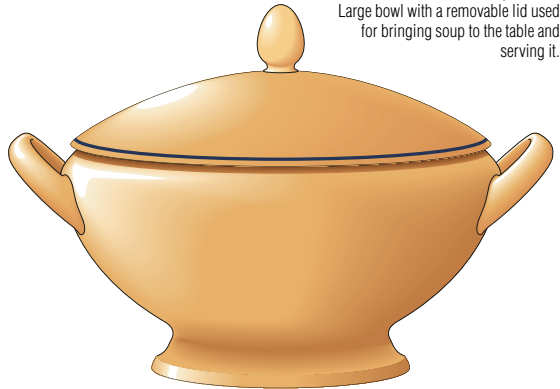
**soup tureen**

Large bowl with a removable lid used for bringing soup to the table and serving it.

salad dish

Small container used to serve individual portions of salad.

**salad bowl**

Container of medium depth used to toss and serve salad.

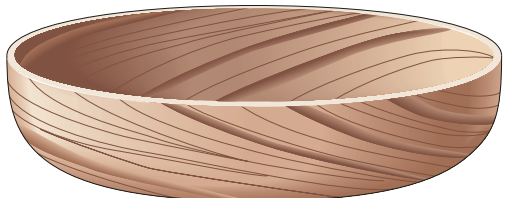

silverware

Utensils used at the table, generally knives, forks and spoons, to which other utensils may be added, depending on the menu.

fork

Utensil with tines used to spear food and carry it to the mouth.

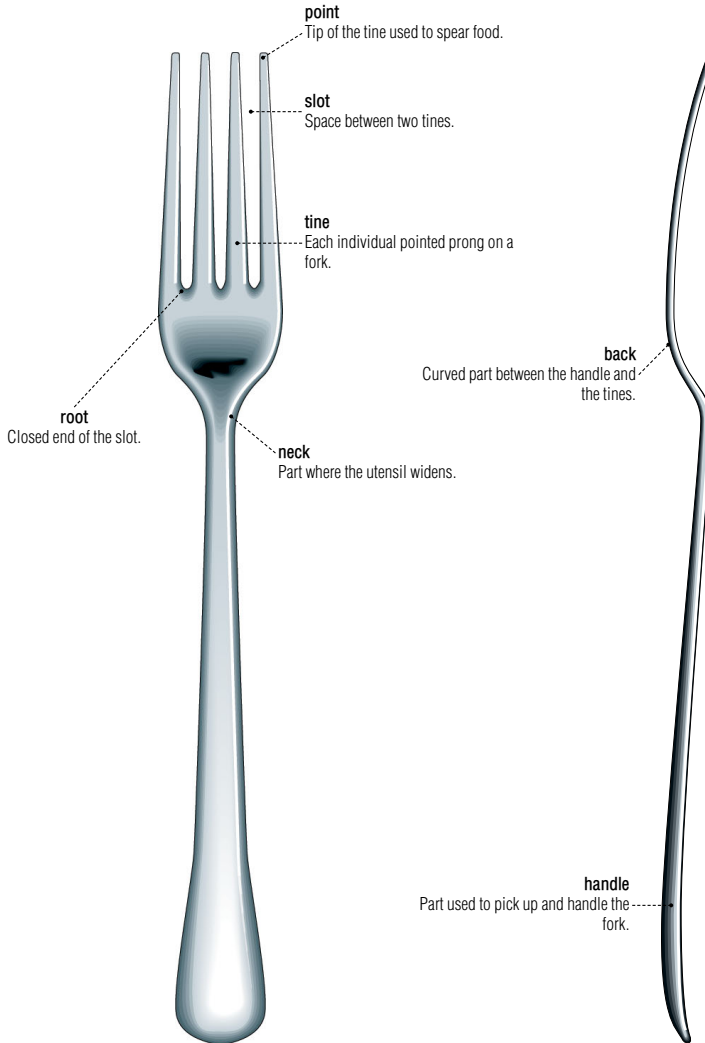

examples of forks

There are many different kinds of forks, each one intended for eating a specific kind of food.

**oyster fork**

Fork used mainly to separate the flesh of a mollusk from its shell.

**dessert fork**

Fork used to cut desserts into bite-sized pieces.

**dinner fork**

Large all-purpose fork that is part of a basic place setting.

**salad fork**

Fork used mainly for eating salad.

**fish fork**

Large fork, usually used for eating fish dishes.

**fondue fork**

Fork used to spear the bread served with a cheese fondue, or the meat served as part of Chinese fondue or fondue bourguignonne.

spoon

Utensil consisting of a handle and a hollow part used to eat liquid or semisolid foods.

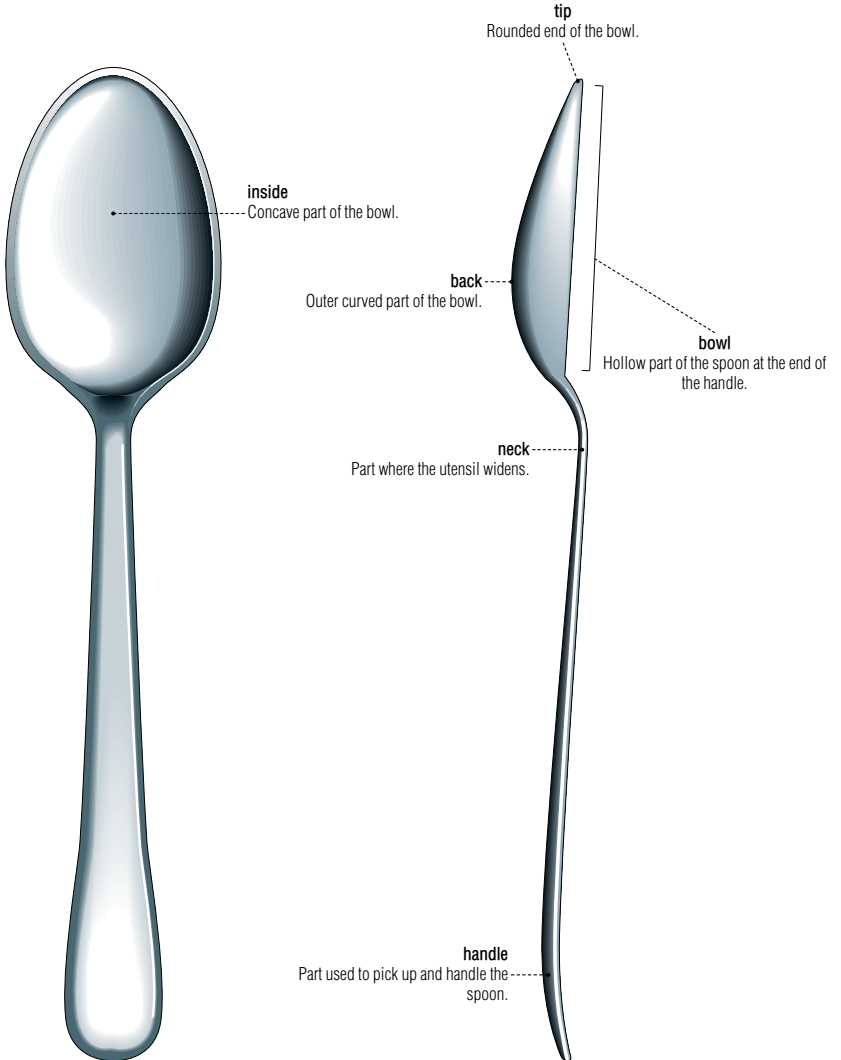

examples of spoons

There are many different kinds of spoons, each with a specific use.

**soup spoon**

Largest spoon, with a capacity of .5 oz.

**teaspoon**

Somewhat larger spoon, with a capacity of 1/6 oz or 1/3 tablespoon.

**coffee spoon**

The smallest utensil in this category, hence sometimes called a small spoon.

**tablespoon**

Spoon used for eating liquid or semiliquid foods; it is part of a basic place setting.

**sundae spoon**

Long-handled spoon used for mixing drinks or eating desserts served in a sundae glass.

**dessert spoon**

Spoon used for eating liquid or semiliquid desserts.

silverware

knife

Piece of silverware consisting of a handle and a sharp blade used to cut food into bite-sized pieces.

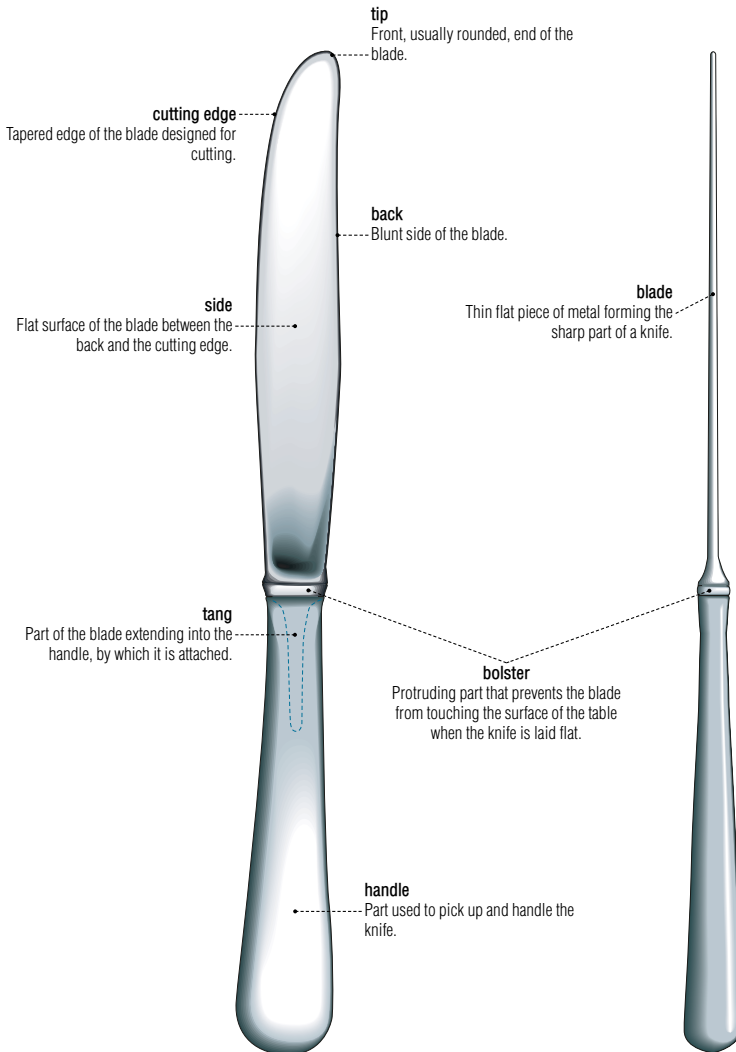

examples of knives

There are many different kinds of knives, each with a specific use.

**fish knife**

Wide-bladed knife used to remove bones from a fish served whole.

dessert knife
Small knife used to cut desserts into bite-sized pieces.

**butter knife**

Blunt knife set out when bread is served and used for buttering it.

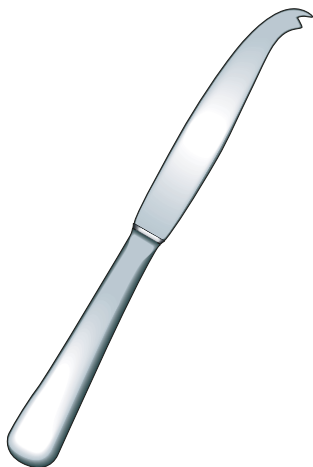
**cheese knife**

Its curved, double-pointed tip makes it easier to spear individual pieces of cheese.

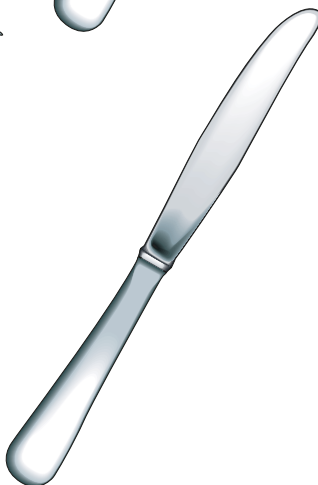
**dinner knife**

Large all-purpose knife that is part of a basic place setting.

**steak knife**

Very sharp knife, often serrated, used to cut firm, often fried, pieces of meat.

kitchen utensils

Accessories or simple mechanical devices used for preparing food.

kitchen knife

Kitchen knives are used to prepare (cut, slice, bone, trim) food.

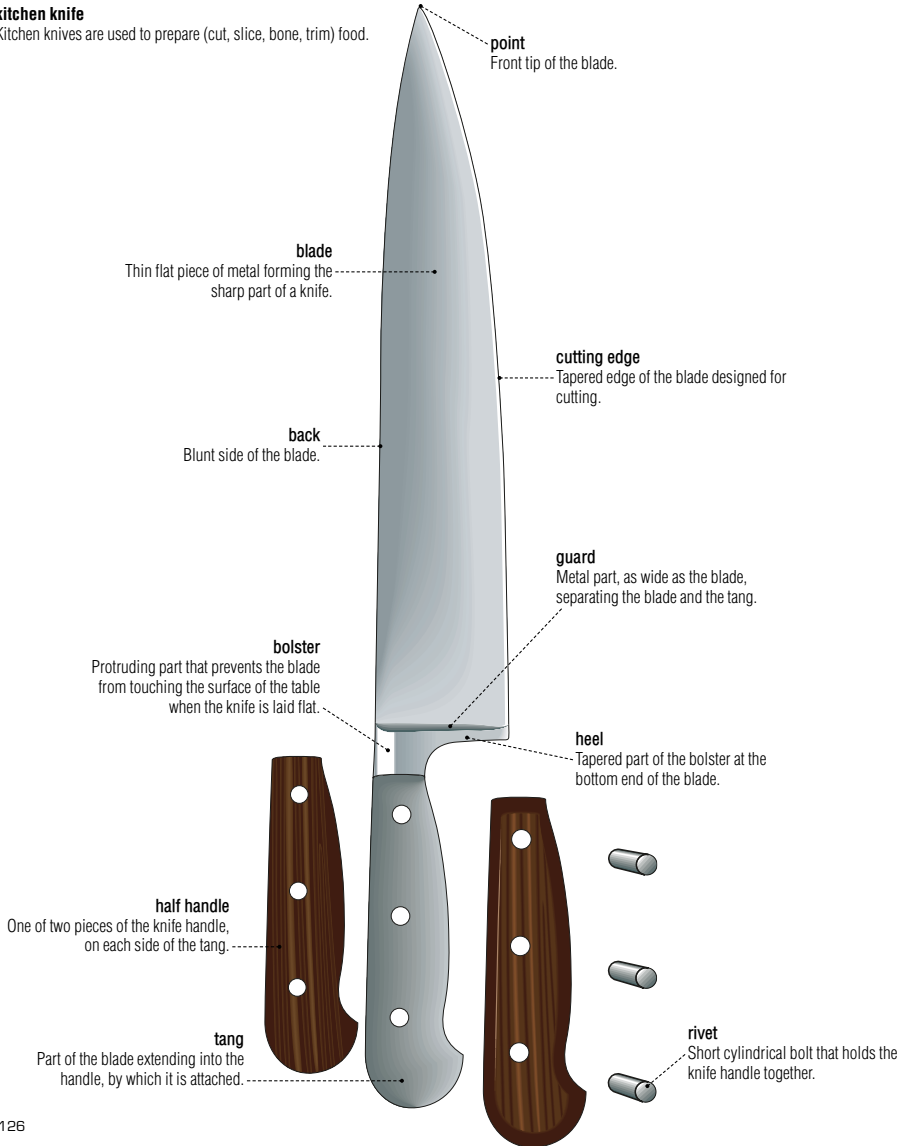

**grapefruit knife**

Knife used to detach citrus fruit pulp.

examples of kitchen knives

The shape and size of kitchen knives vary depending on their use and the type of food for which they are intended.

**boning knife**

Small pointed knife with a tapered blade used to separate the meat from the bones.

**filleting knife**

Knife with a long pointed blade used for separating fish into fillets.

**cleaver**

Knife with a wide rigid blade heavy enough to break bones.

**paring knife**

Miniature version of the cook's knife, it is used to clean, scrape and slice small pieces of food.

**ham knife**

Knife with a ridged blade used to cut whole cooked ham.

**carving knife**

Knife with a narrow blade used to slice pieces of cooked meat into portions.

bread knife
Serrated knife used for cutting fresh bread.

**cook's knife**

Knife with a wide range of uses, from cutting large pieces of meat to chopping fresh herbs.



zester

Knife whose blade curves at the end and has five small cutting holes; it is used to remove thin strips of rind from citrus fruits.



peeler

Its pivoting blade follows the contours of the fruits and vegetables it is used to peel.



carving fork

Fork used to hold a piece of meat in place when it is being cut into portions.

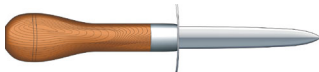

oyster knife

Double-edged knife with a guard to open oyster shells by severing the muscle that holds them closed.



butter curler

Utensil with a serrated hook that creates butter curls when scraped across cold butter.



sharpening steel

Cylindrical steel rod with narrow grooves used for honing a knife edge.

sharpening stone

Abrasive stone used to sharpen knife edges.

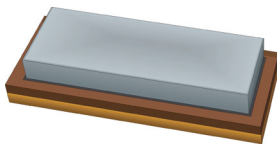

cutting board

Made of plastic or wood and used for cutting up foods.



groove

Furrow where cooking juices collect.

for opening

Instruments that remove lids, caps or corks from containers in order to provide access to their contents.

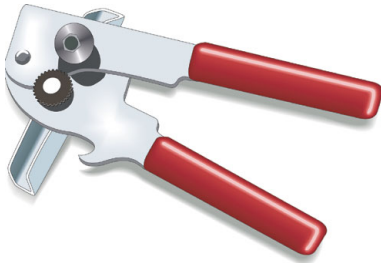
**can opener**

Tool used to open cans by cutting along the inside edge of the lid.

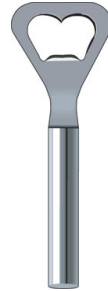
**bottle opener**

Instrument used to remove caps from bottles.

**lever corkscrew**

Instrument with a screw and two wings that rise as the screw penetrates the cork; they then act as levers to open the bottle.

**wine waiter corkscrew**

Instrument with a screw and a lever that open wine bottles by leverage, a blade for cutting the hood around the top, and a bottle opener.

kitchen utensils

for grinding and grating

Instruments that can reduce food to fine particles, shavings, powder, purées, etc.

**nutcracker**

Tongs used to break nutshells and release the kernel inside.

**garlic press**

Utensil used to finely crush garlic cloves.

**nutmeg grater**

Small conical grater used to reduce nutmeg seeds to a powder.

mortar

Hemispheric receptacle made of marble, porcelain or hardwood in which certain foods can be ground with a pestle.

**pestle**

Usually heavy instrument whose short handle extends into a head; it is used mainly to grind seeds, dry ingredients and garlic.

food mill

Instrument used to reduce cooked fruit and vegetables to a purée, the consistency of which depends on the disk used.

**mandoline**

Instrument comprising interchangeable cutting blades inserted in a frame; it slices vegetables in different ways, depending on the blade used.

**citrus juicer**

Instrument used to express juice from citrus fruits, usually lemons or oranges.

**meat grinder**

Instrument with a knife and interchangeable disks used to grind meat; the perforations in the disks determine the size of the grind.

rotary cheese grater

Instrument used to grate cheese by scraping it against the teeth of a rotating drum.

pusher
Bent part of the handle that presses the piece of cheese against the drum.

crank
Angled lever that makes the drum rotate.

drum
Cylindrical part of the utensil that grates the cheese.

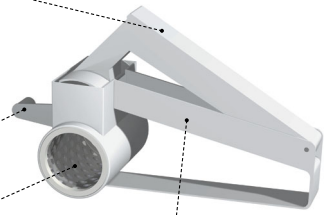

handle
Part enabling the user to hold the grater and exert pressure on the pusher.

**pasta maker**

Instrument that can roll out and cut pasta dough into different shapes with its removable blades.

**grater**

Instrument used to reduce food such as vegetables, cheese and nuts into fine particles or a powder.

kitchen utensils

for measuring

Instruments designed to measure the volume or weight of ingredients, food temperature, and cooking or preparation time.

**kitchen timer**

Device used to measure a period of time; once that time has elapsed, the timer rings.

**measuring spoons**

The bowls on these spoons correspond to an exact quantity of an ingredient, and are used to measure it.

**measuring cup**

Graduated container with a pouring spout used for measuring liquids.

**egg timer**

Device with two glass vials, one of which is filled with sand; the flow of the sand between the vials measures a precise time period.

**measuring cups**

Receptacles used to measure the exact quantity of an ingredient.

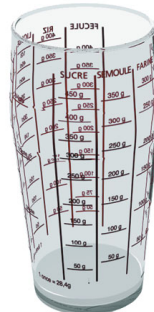
**measuring beaker**

Graduated container used to measure dry and liquid ingredients.



meat thermometer

Thermometer inserted into a roast to check its degree of doneness.



candy thermometer

Thermometer that is placed in hot liquid sugar mixtures to measure their exact temperature.



oven thermometer

Thermometer that is placed inside an oven to check the exact temperature.



instant-read thermometer

Digital thermometer that, when inserted into a roast, instantly indicates the meat's internal temperature.

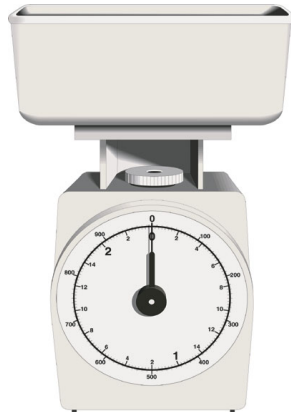

kitchen scale

Instruments used to weigh dry ingredients (e.g., flour, sugar, rice).

kitchen utensils

for straining and draining

Instruments used to filter dry or liquid foods, or to remove the liquid used to wash, blanch, cook or fry certain foods.

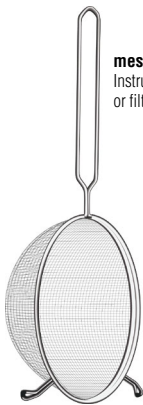
**mesh strainer**

Instrument used to sift dry ingredients or filter liquid ones.

**colander**

Instrument used to drain food.

**funnel**

Cone-shaped instrument ending in a tube used to pour liquid into a narrow-necked container.

**muslin**

Cloth woven into a fine loose mesh and used to strain creamed soups and sauces so they become finer and smoother.

**salad spinner**

Apparatus that uses centrifugal force to remove water from freshly washed lettuce leaves.

**chinois**

Finely meshed cone-shaped strainer used to filter broth and sauces, and to reduce food to a purée.

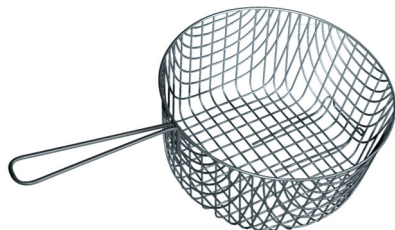
**fry basket**

Metal mesh receptacle designed to hold foods during frying and drain them afterward.

**sieve**

Strainer made of woven nylon, metal or silk strands and attached to a wooden frame; it is used to strain dry and liquid ingredients.

baking utensils

Baking: refers to the production of cakes, cookies and other usually sweet comestibles made from cooked dough, pastry or batter.

**egg beater**

Mechanical device with two whisks activated by a crank handle; it is used to beat liquid and semiliquid ingredients.

**icing syringe**

Fitted with interchangeable nozzles that are filled with icing, it is used to decorate baked goods and molded desserts.

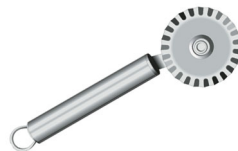
**pastry cutting wheel**

Device used for cutting dough; the indented wheel gives it a fluted edge.

cookie cutters

Hollow metal molds used to cut dough into soft shapes that will be retained after baking.

**sifter**

Device used to sieve flour; it has a spring-loaded handle that moves the flour about and makes it lighter.

**pastry bag and nozzles**

Leakproof bag into which interchangeable nozzles are inserted; it is used to decorate dishes, baked goods and molded desserts, or to make pastries.

**whisk**

Utensil made of several curved and intersecting steel wires used to blend, beat or whip liquid and semiliquid ingredients.

**pastry brush**

Device with silk or nylon bristles at one end, used to coat, brush or glaze pastries, or to grease baking pans.



**baking sheet**

Rectangular pan with low sides, usually made of aluminum, used for baking cookies, cakes and other pastries that do not require molding.

dredger
Container with a perforated lid used for sprinkling food with flour, sugar or grated cheese.

**pastry blender**

Utensil used to blend fatty ingredients with flour.

**rolling pin**

Wooden cylinder that rolls freely between two lateral handles; it is used to roll out pastry.

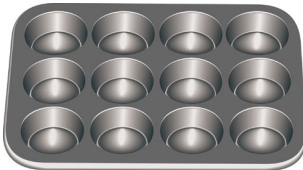
**muffin pan**

Baking pan with indentations used to give muffins their distinctive shape.

**mixing bowls**

Round containers of various sizes used to prepare or mix food and ingredients.

**cake pan**

Relatively deep metal baking pan with enough room to allow the cake to rise.

**soufflé dish**

Deep porcelain dish that prevents the rising soufflé from overflowing as it cooks.

**pie pan**

Metal pan used to make a pie crust and to bake a pie in the oven.

**quiche plate**

Metal baking pan with a scalloped edge that makes the crust of the quiche more attractive.

**removable-bottomed pan**

Metal baking pan whose bottom, and sometimes its side, come apart so the contents can be removed more easily.

**charlotte mold**

Deep metal pan shaped like a pail and used to cook a cream-based sweet dessert surrounded by biscuits.

kitchen utensils

set of utensils

Main kitchen utensils, often matching, stored in a stand.

**spatula**

Long blade of variable width used to turn food over during cooking.

**draining spoon**

Large elongated slightly concave spoon with perforations; it is used to remove small pieces of food from their cooking liquid.

**skimmer**

Large round slightly concave spoon with perforations; it is used to skim broth and sauce, or to remove food from its cooking liquid.

**potato masher**

Utensil used to manually purée cooked fruits and vegetables.

**turner**

Utensil used to handle cooked food without breaking it.

**ladle**

Spoon with a deep bowl and a long handle; it is used to decant liquid or semiliquid food.

miscellaneous utensils

**stoner**

Tonglike device used to remove stones from olives and cherries without damaging the flesh.

**melon baller**

Spoon used to cut small round pieces from the flesh of fruits or vegetables.

**apple corer**

Utensil used to remove the core from apples and pears.

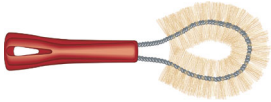
**vegetable brush**

Utensil used to clean certain vegetables, such as potatoes.

**trussing needle**

Tool used to thread pieces of string through poultry or to tie a roast.

**larding needle**

Tool used to insert strips of lard, ham or truffles into cuts of meat.

**tasting spoon**

Wooden spoon consisting of two bowls joined by a shallow groove used to take and taste liquids.

**ice cream scoop**

Spoon used to remove a serving of ice milk or ice cream from a container.



kitchen shears

Multipurpose utensil used for cutting fresh herbs, trimming meat and vegetables.



poultry shears

Utensil used to cut poultry into pieces.



snail tongs

Utensil used to hold snail shells so the snail can be extracted.



tea ball

Hollow sphere that holds dried tea leaves during steeping.



egg slicer

Device that uses taut steel wires to slice a hard-boiled egg.

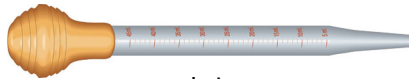

baster

Utensil with a graduated tube and a rubber bulb; it is used to suck up cooking liquid and drizzle it over the meat.

tongs

Utensil used for holding, turning and serving food.



spaghetti tongs

Two-armed utensil with teeth at the end that facilitate serving long strips of pasta.



snail dish

Has several indentations for holding snails when they are served.

Utensils used for cooking food, especially in the oven or on the stove.

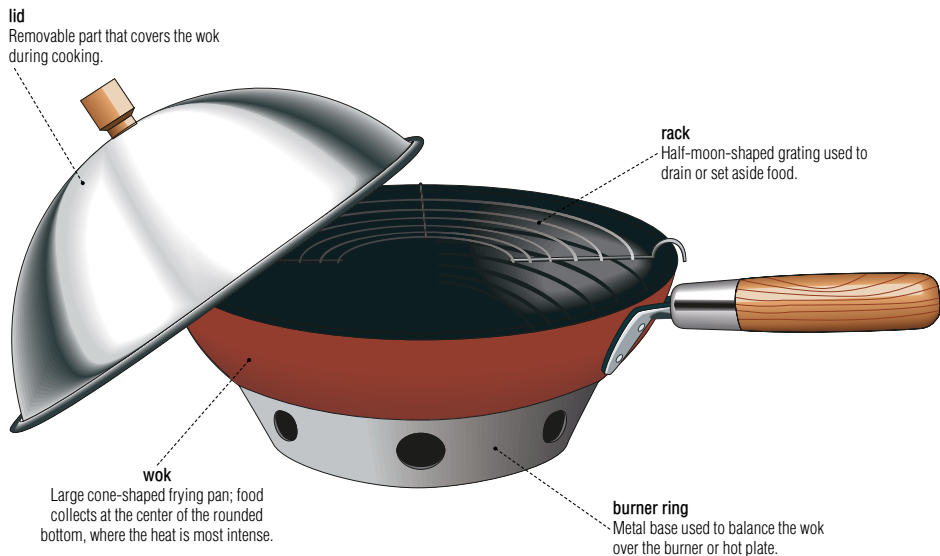
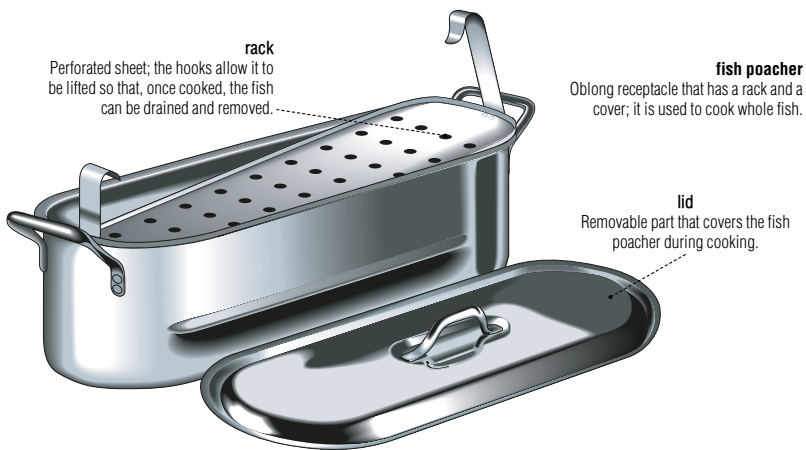

cooking utensils

fondue set

Utensil designed to prepare and serve various kinds of fondue, such as meat, cheese or chocolate.

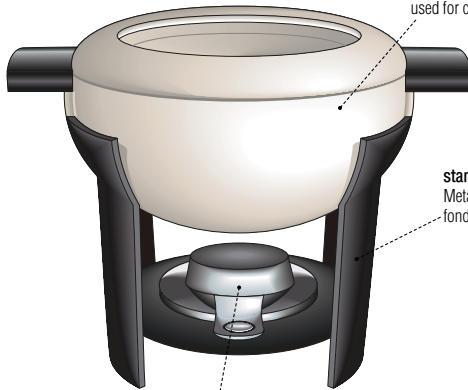
**fondue pot**

Container with one or two side handles used for cooking fondue.

stand

Metal base designed to hold the fondue pot and the burner.

burner

Compartment containing a flammable liquid that keeps the fondue pot warm throughout the meal.

**tajine**

Varnished earthenware dish with a cone-shaped airtight lid used in the Maghreb to cook an eponymous dish.

pressure cooker

Stock pot with a screw-on, airtight lid designed to cook food rapidly using pressurized steam.

**pressure regulator**

Device maintaining the pressure at a constant level.

safety valve

Device that regulates escaping steam when the stock pot is under pressure.

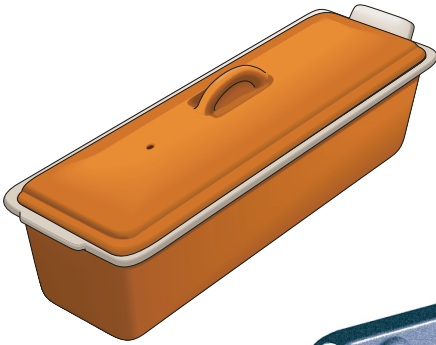
**terrine**

Container with a perforated lid that allows steam to escape; it is designed for cooking recipes with or without jelly.

**dripping pan**

Slightly concave rectangular pan used to roast meat or to catch the meat's cooking juices.

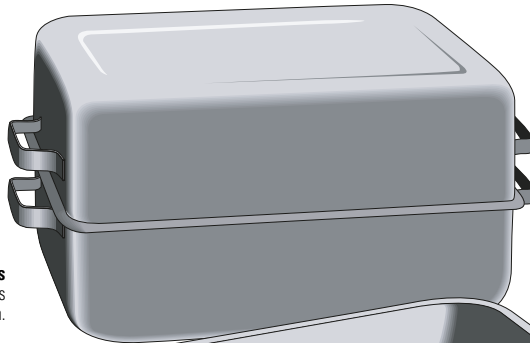
**roasting pans**

Somewhat deep large-capacity utensils used to roast meat in the oven.

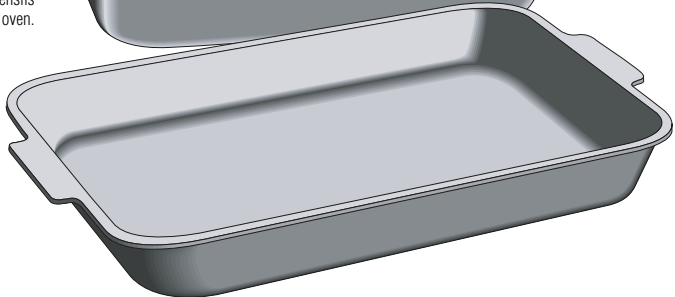

**Dutch oven**

Somewhat deep stock pot used for cooking food in a liquid.

**stock pot**

Container used for cooking large quantities of food in a liquid.

**steamer**

Utensil comprising two saucepans; the steam from the boiling water in the bottom one cooks the food in the top one.

**steamer basket**

Perforated receptacle that is placed in a saucepan above the water level and filled with food to be steam-cooked.

**couscous kettle**

Double container in which steam from the broth in which the food in the bottom part is simmering cooks and flavors the semolina in the top part.

egg poacher
Device used to poach eggs by placing them in indentations in a tray suspended over a hot liquid.



**frying pan**

Utensil used to fry, sauté or brown food.

**sauté pan**

Similar to a frying pan but with a straight edge, used to cook food in fat, over high heat.

**pancake pan**

Round thick-bottomed skillet with a shallow edge that allows a spatula to loosen and flip the pancake.

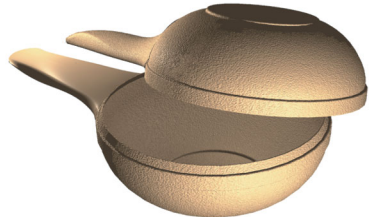
**diable**

Utensil composed of two skillets of porous clay that fit tightly together; it is used for braising food.

**saucepan**

Low-sided receptacle commonly used to heat liquids or cook food in a liquid.

**small saucepan**

Deeper than a frying pan, this utensil is used to simmer or braise dishes.

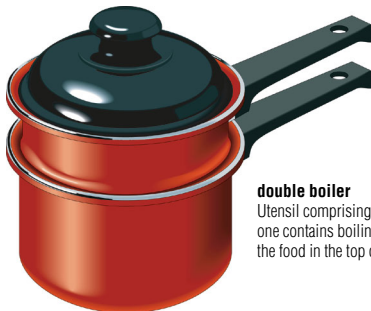
**double boiler**

Utensil comprising two saucepans; the bottom one contains boiling water, which cooks or heats the food in the top one.

domestic appliances

Domestic appliances operating on electricity.

for mixing and blending

Appliances used for stirring, for blending several ingredients together or for changing the appearance of an ingredient.

blender

Electric appliance comprising a motor unit with a container on top, in which raw or cooked food is mixed, crushed or puréed.





domestic appliances

hand mixer

Electric appliance comprising two beaters and a motor unit used to beat or mix liquid or semiliquid food.



beaters

Instruments used to mix, beat or knead liquid or semiliquid foods.

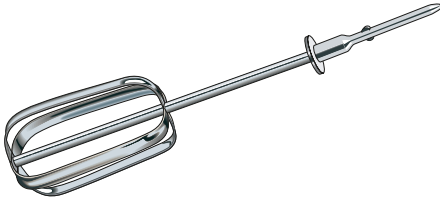
**four blade beater**

All-purpose beater used to mix, beat or whisk various ingredients.

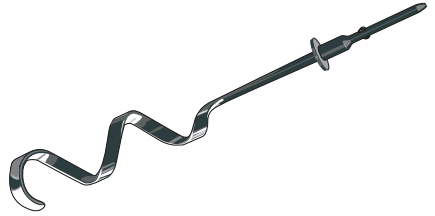
**spiral beater**

Beater used primarily to mix and knead light dough.

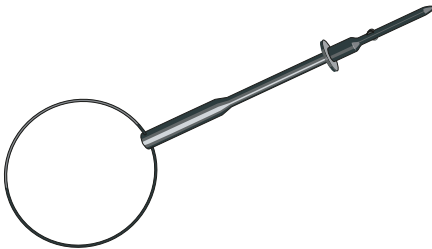
**wire beater**

Beater used to mix, emulsify or beat many different ingredients or to incorporate air into a mixture.

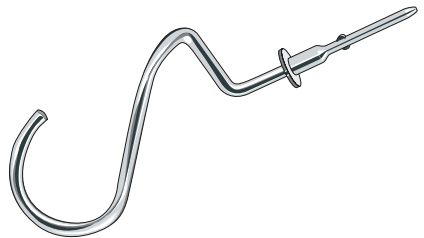
**dough hook**

Beater used to mix and knead dough.

domestic appliances

hand blender

Electric appliance with a handheld motor unit; less powerful than the blender, it is used for mixing liquids and grinding soft foods.

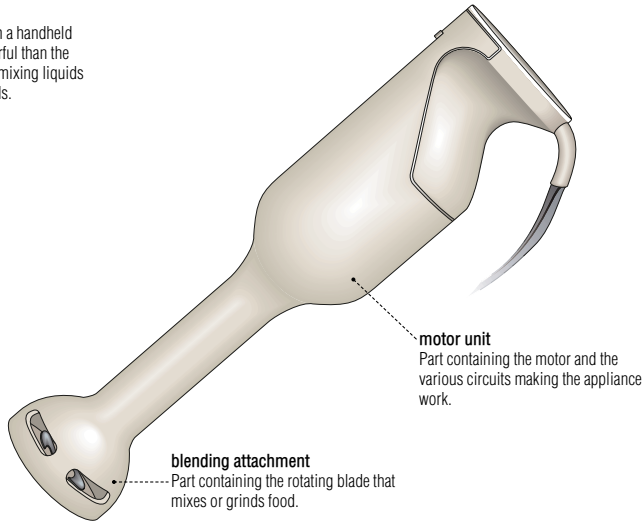
**for juicing**

Device designed to extract juice from fruit, especially citrus fruit, when pressure is exerted upon it.

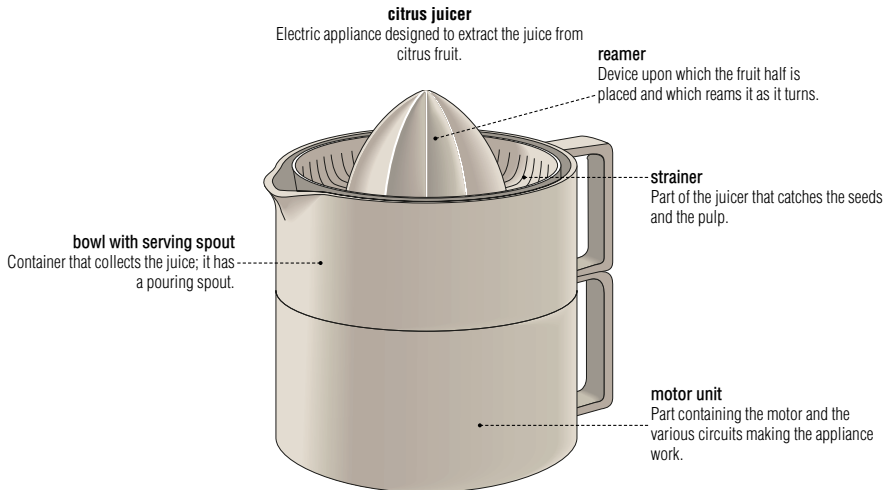

for cutting

Appliances used primarily for separating elements into small parts or portions.

food processor

Electric appliance comprising a motor unit, a blade and a set of disks used for cutting, chopping, slicing, grating, mixing, kneading, etc.

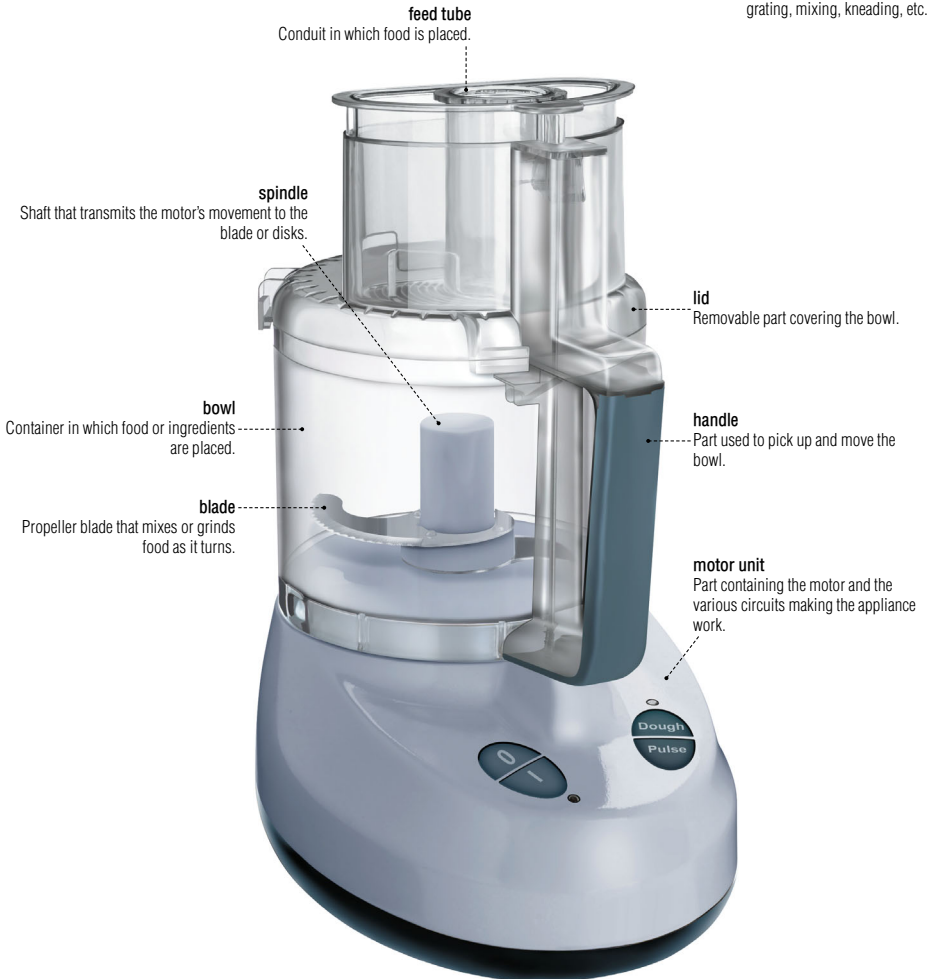

domestic appliances

gas range

Appliance for cooking food, equipped with gas-fed burners and an oven.



electric range

Electric appliance for cooking food, equipped with surface elements or griddles and an oven.



microwave oven

Appliance that generates high-frequency waves to quickly heat or cook food.

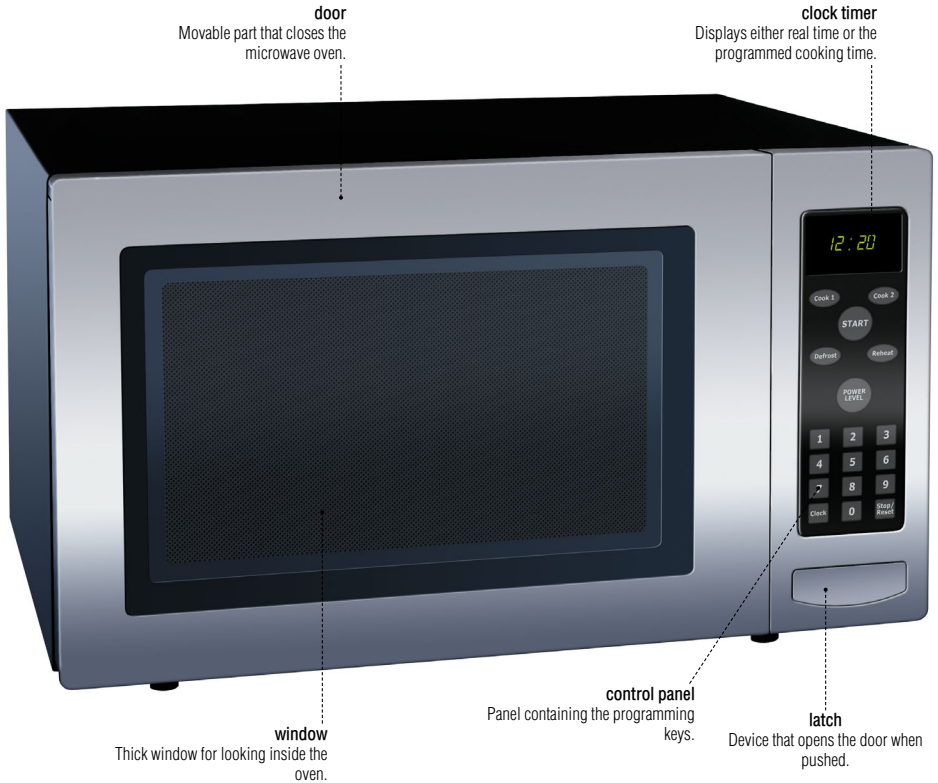

domestic appliances

chest freezer

Large horizontal appliance for conserving food at a very low temperature (0°F).

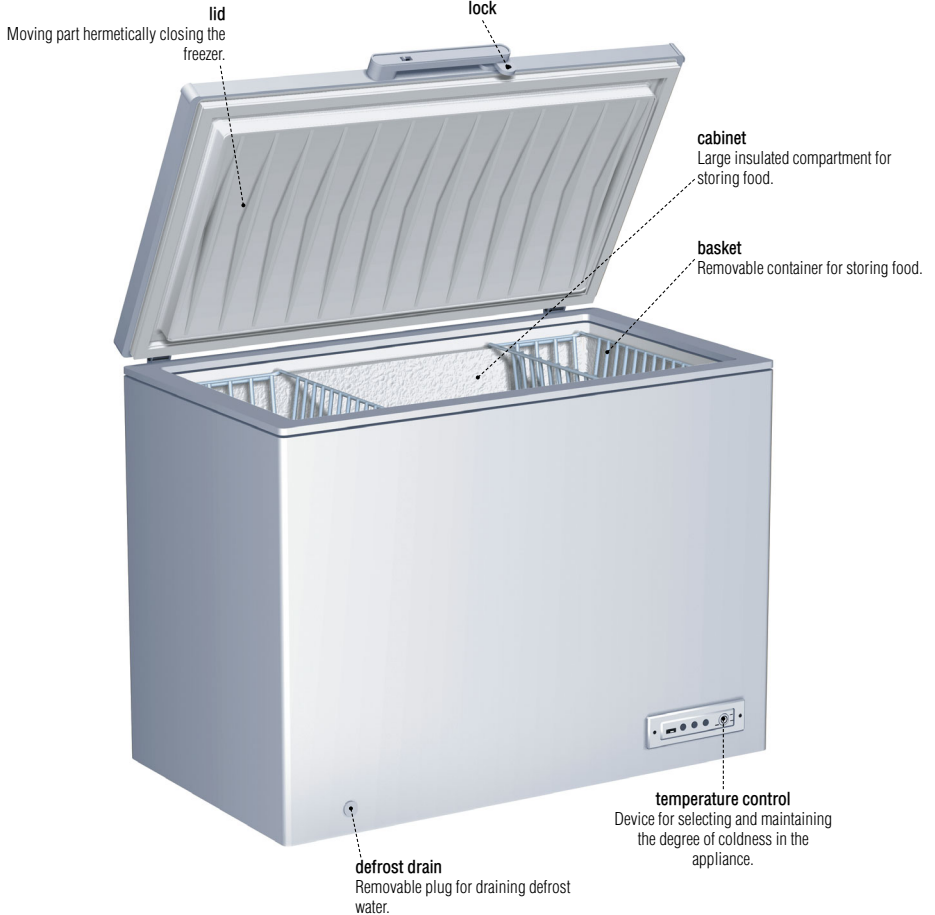

refrigerator

Appliance with two compartments, one for keeping food cold and the other for freezing it.



domestic appliances

for cooking

Appliances that bring raw food into contact with a heat source in order to cook them.

deep fryer

Container with a heating element that raises the temperature of fat high enough to deep-fry food.

basket
Wire mesh container with a detachable handle designed to hold foods during frying and drain them once cooked.

lid
Removable part that covers the deep fryer during cooking.

handle
Device used to raise or lower the basket.

thermostat
Device used to regulate fat temperature.

signal lamp
Light indicating when the desired temperature has been reached.

timer
Device used to monitor cooking time.



bread machine

Electric appliance used to raise and bake bread dough.

window

Thick glass through which the bread dough can be seen inside the mold.

lid

Movable part that closes the bread machine.

control panel

Panel containing the programming keys.

loaf pan

Container for the bread dough, which, once baked, will become bread.



domestic appliances

raclette with grill

Appliance with covered heating elements used to melt cheese or grill meat and side vegetables.

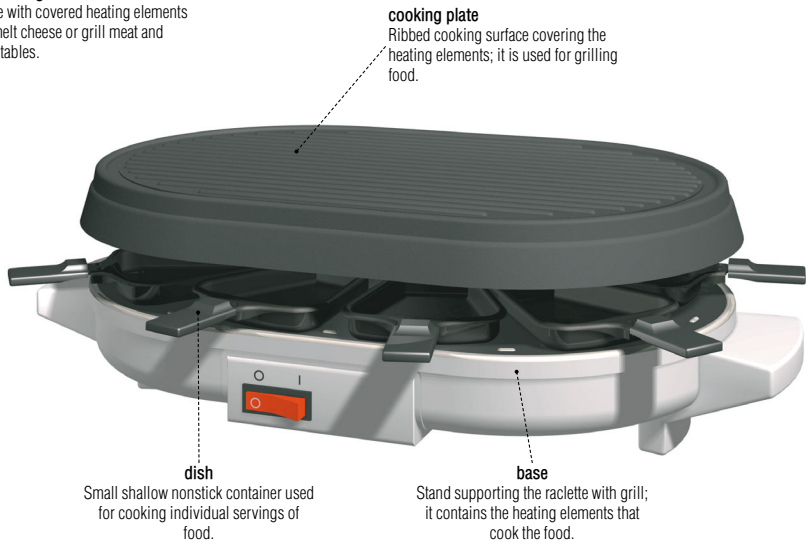
**indoor electric grill**

Electric appliance comprising a metal grill and a heating element used to cook food.

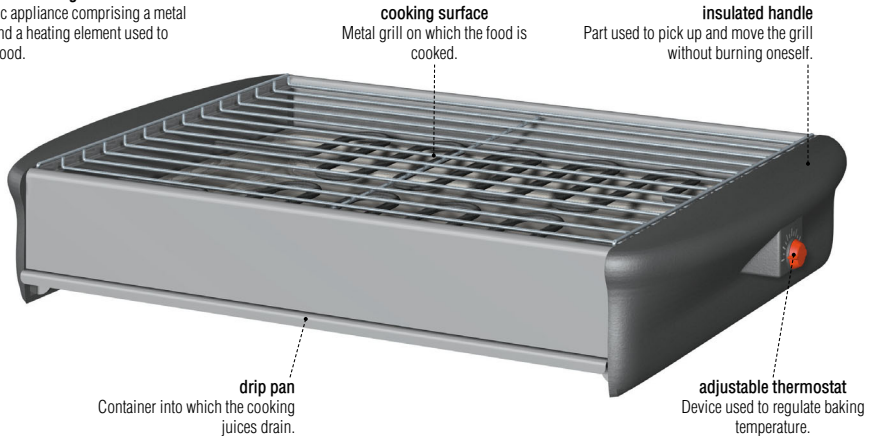

toaster

Appliance with heating elements that toast slices of bread.



griddle

Electric appliance comprising a cooking surface and used for grilling food.

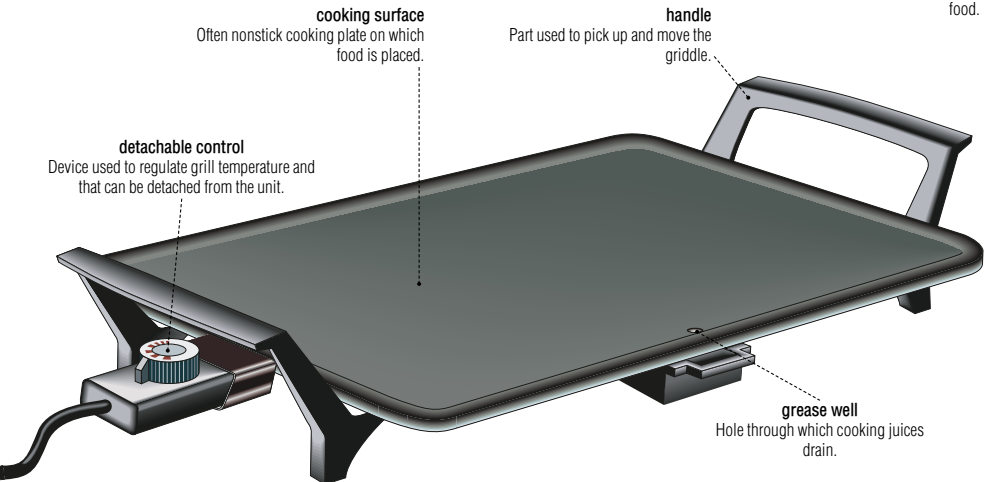

electric steamer

Electric appliance comprising two dishes resting on a water-filled base; it is used to steam food separately.

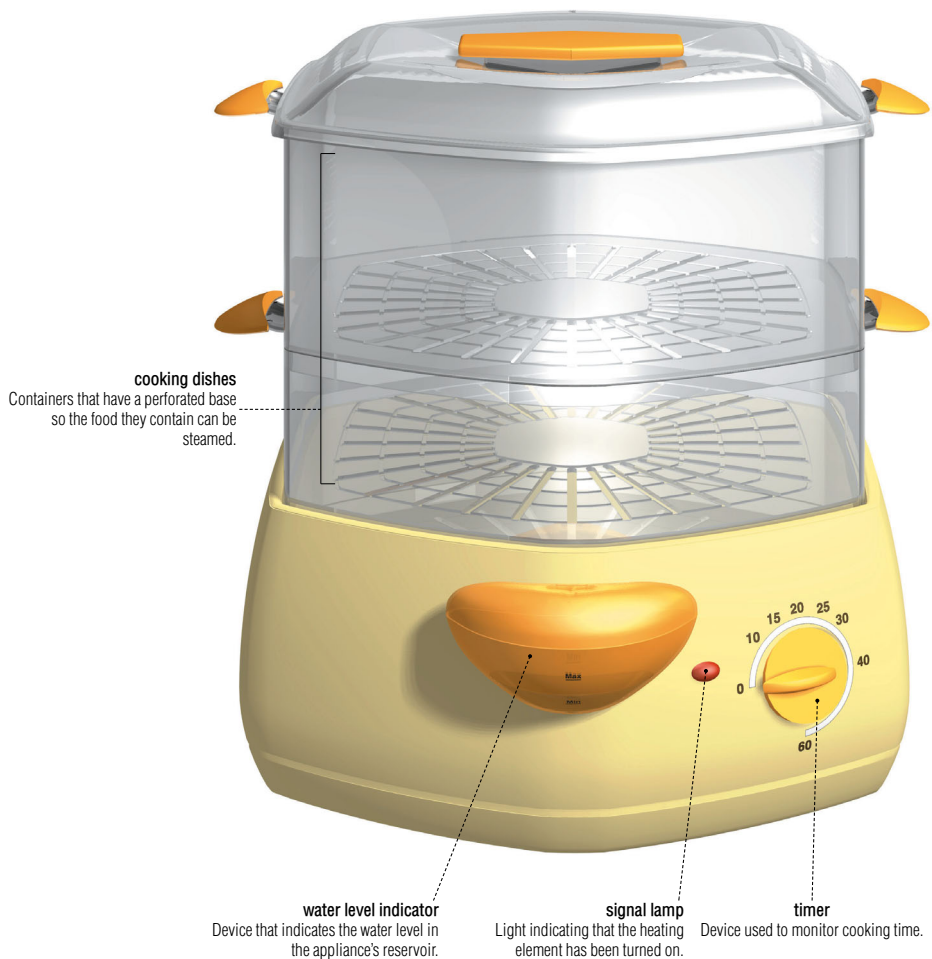

waffle iron

Appliance comprising two indented plates, each one covering a heating element; it is used to cook waffles or grill food.

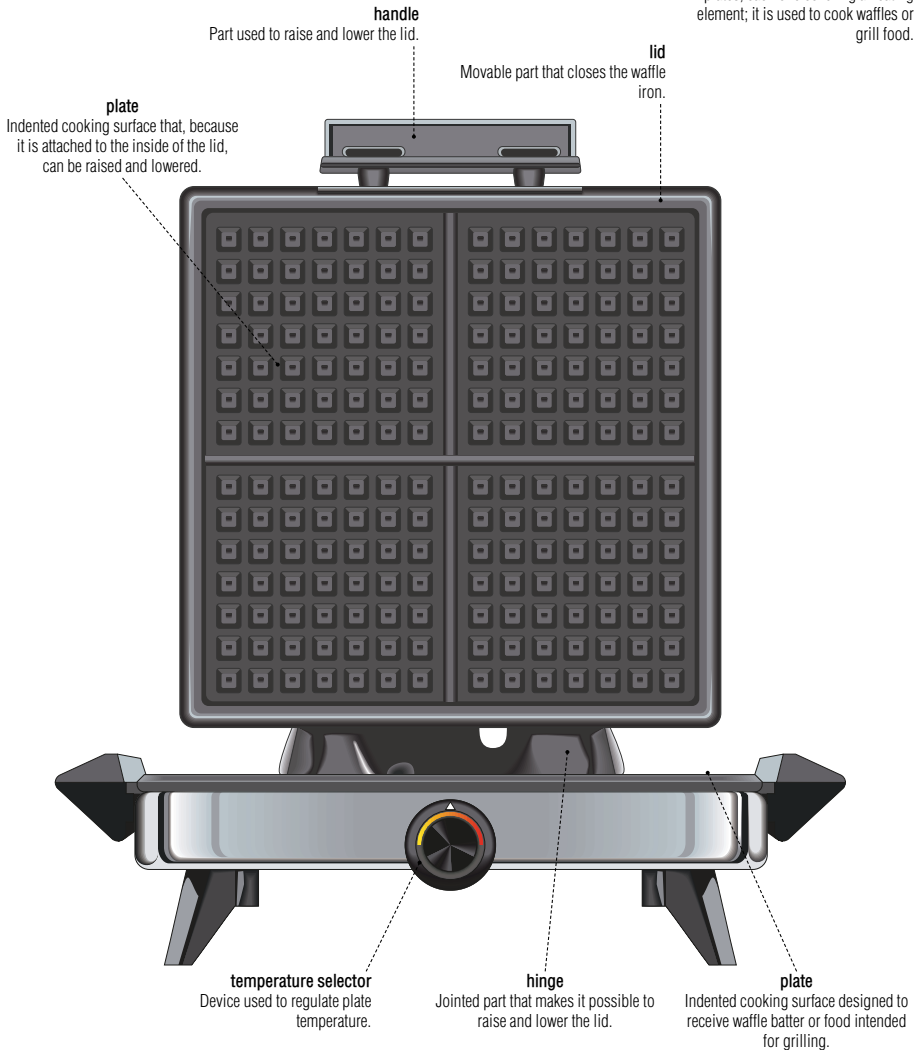

miscellaneous domestic appliances

can opener

Tool used to open cans by cutting along the inside edge of the lid.

pierce lever

Device connected to the blade that the user presses down so it pierces the can lid.

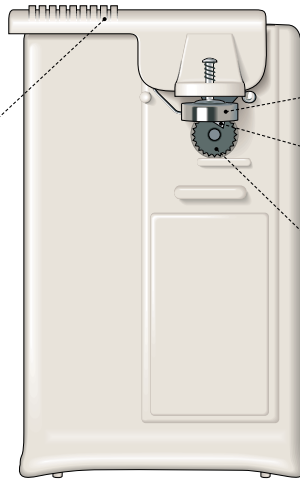
**magnetic lid holder**

Part that holds the lid once it has been removed from the can.

cutting blade

Knife that separates the lid from the can.

drive wheel

Cogwheel that helps rotate the can so the lid can be removed.

kettle

Container with a heating element used to boil water.

spout

Small tapered projection used to pour the boiling liquid.

body

Part of the kettle that holds the water to be boiled.

base

Stand supporting the kettle; it contains the heating element that boils the water.

handle

Part used to pick up and move the kettle.

on-off switch

Button for turning the device on or off.

signal lamp

Light showing that the appliance is on.



juicer

Appliance that uses centrifugal force to extract the juice from vegetables and fruit, except citrus fruits, which must be reamed.

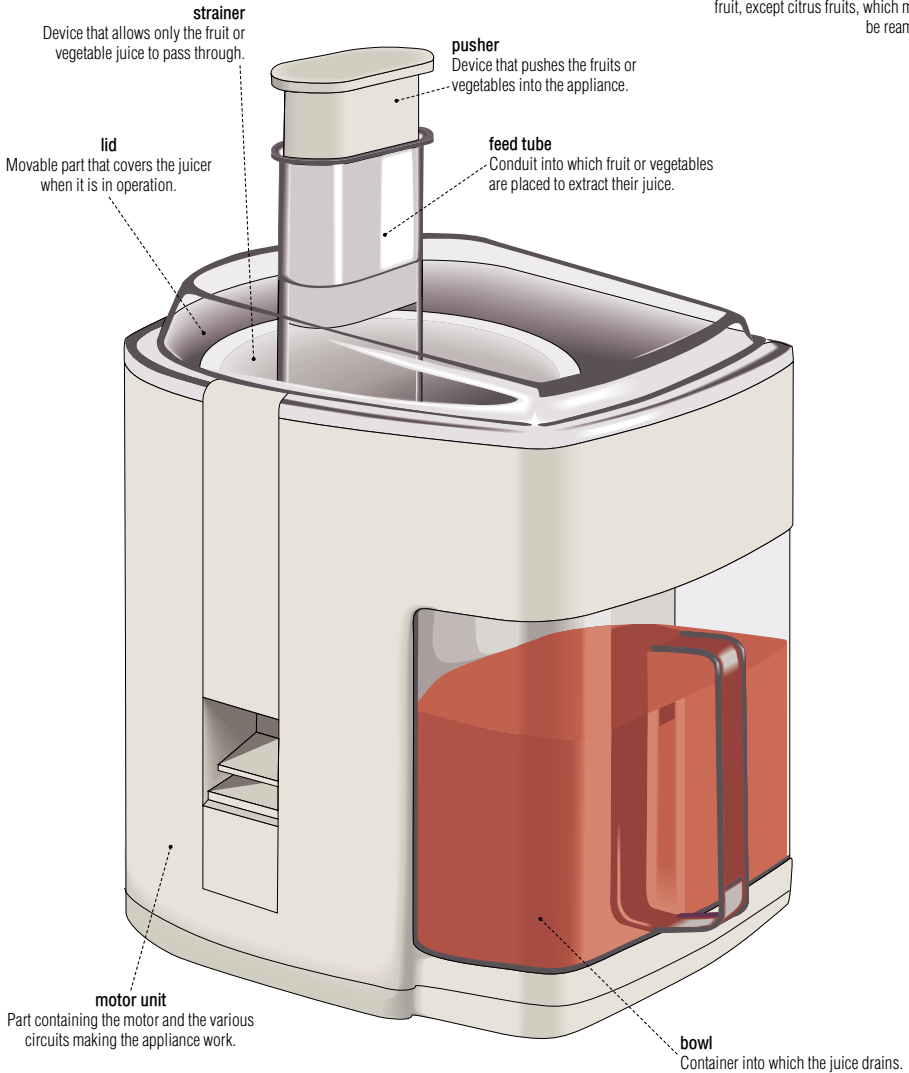

miscellaneous domestic appliances

ice cream freezer

Appliance comprising a freezer bucket in which revolving paddles make sherbet and ice cream.

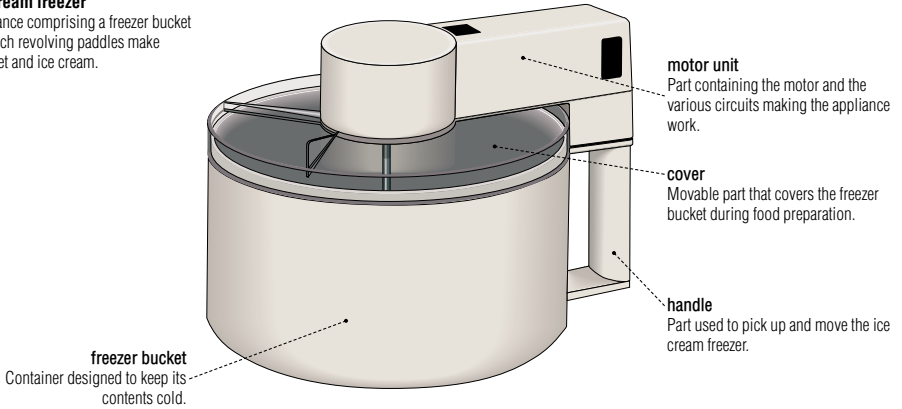

coffee mill

Appliance that uses a rotating blade to finely grind coffee beans or other items, such as spices.

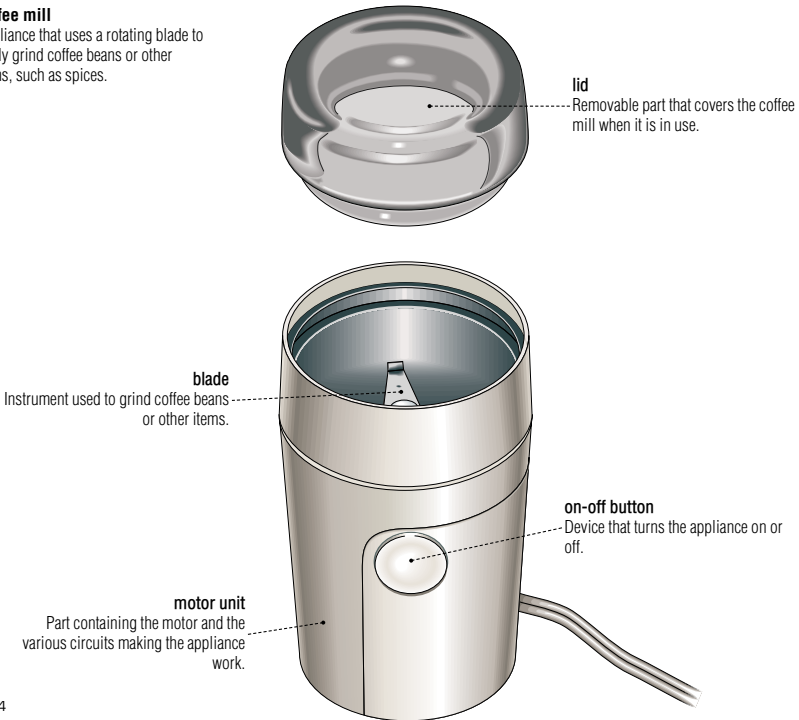

Utensils used to brew coffee; each of the various models produces coffee that has a distinctive flavor.

automatic drip coffee maker

Electric coffee maker that allows hot water to drain into a paper filter containing the ground beans, and coffee to drip into the carafe below.



coffee makers

Neapolitan coffee maker

Coffee maker that is placed on a heat source to boil the water; it is then turned over so the boiling water filters through the ground beans into the serving compartment.

**plunger**

Coffee maker that allows hot water to be poured over ground beans; once the grounds have steeped, the plunger is depressed to push the grounds to the bottom of the carafe.

**espresso coffee maker**

Coffee maker that allows boiling water from the lower compartment to be forced through the ground beans into the upper compartment.



espresso machine

Electric coffee maker that allows hot water to be forced under pressure through the ground beans.



coffee makers

vacuum coffee maker

Coffee maker that brews coffee by causing the water to pass through the ground beans twice.

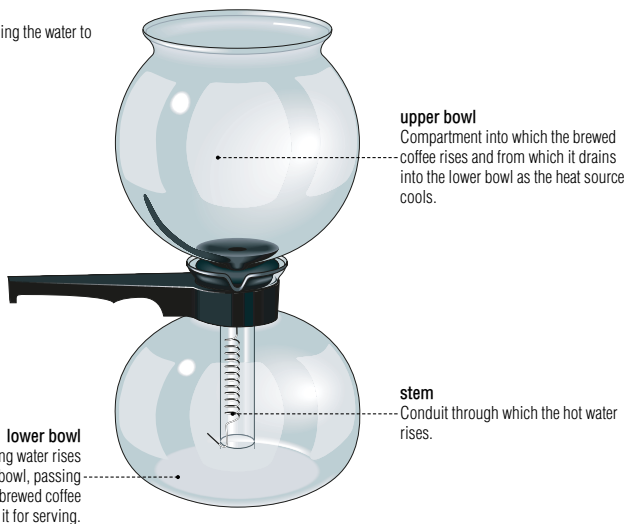
**percolator**

Electric coffee maker that allows the hot water to rise several times through a tube to percolate through ground beans.



ENGLISH INDEX

A

abalone 98
 acorn squash 33
 adjustable thermostat 158
 adzuki bean 39
 agar-agar 18
 aisle 10
 ajowan 56
 alfalfa 36
 alkengi 43
 all-purpose flour 66
 allspice 54
 almond 44
 Alsace glass 114
 aluminum foil 108
 amaranth 65
 American bacon 91
 American corn bread 71
 American mustard 59
 anchovy 102
 andouillette 93
 anise 62
 apple 50
 apple cider vinegar 61
 apple corer 139
 apricot 41
 arame 18
 artichoke 30
 arugula 29
 asafetida 56
 Asian noodles 74
 Asian pear 53
 asparagus 23
 Atlantic cod 106
 Atlantic salmon 107
 automatic drip coffee maker 165
 autumn squash 33
 avocado 31

B

back 120, 122, 124, 126
 back ribs 94
 back waiter 15
 bacon 91
 bagel 68
 baguette 68
 bakery 11
 baking sheet 136
 balsamic vinegar 61
 bamboo shoot 24
 banana 51
 bar 12
 bar counter 12
 bar stool 12
 barley 65
 barmaid 12
 bam 8
 base 158, 162

base cabinet 112
 basil 62
 basket 154, 156, 165
 basmati rice 67
 bass 104
 baster 140
 beaker 132
 bean thread cellophane noodles 74
 beans 36, 39
 beater 147, 148
 beater ejector 147, 148
 beaters 149
 beauty care 11
 beechnut 45
 beef cubes 94
 beef, cuts 94
 beer 10
 beer mug 115
 beet 35
 Belgian endive 29
 bergamot 46
 berries 42
 beverage can 110
 bilberry 42
 bird's eye chile 56
 bitter melon 32
 black bean 40
 black currant 42
 black gram 40
 black mustard 54
 black pepper 54
 black pollock 106
 black radish 34
 black rye bread 68
 black salsify 35
 black tea 77
 black-eyed pea 38
 blackberry 43
 blade 124, 126, 151, 164
 blender 146
 blending attachment 150
 blood sausage 93
 blue mussel 99
 blue-veined cheeses 85
 blueberry 42
 bluefish 105
 body 162
 bolster 124, 126
 boning knife 127
 bony fishes 102
 booth 13
 borage 63
 bordeaux glass 114
 bottle opener 129
 bowl 122, 151, 163
 bowl with serving spout 150
 brains 88
 branch 25

brandy snifter 114
 Brazil nut 45
 bread 68
 bread and butter plate 117
 bread guide 159
 bread knife 127
 bread machine 157
 brick carton 111
 Brie 86
 broad beans 36
 broccoli 30
 broccoli rabe 30
 brook trout 106
 brown rice 67
 brown sugar 79
 Brussels sprouts 27
 buckwheat 65
 buffet 13
 bulb 24
 bulb vegetables 19
 bundle 23
 bunker silo 9
 burdock 35
 burgundy glass 114
 burner 142, 152
 burner control knobs 152
 burner ring 141
 butter 81
 butter compartment 155
 butter cup 111
 butter curler 128
 butter dish 117
 butter knife 125
 butterhead lettuce 26
 buttermilk 82

C

cabbage 27
 cabinet 112, 154
 cajun spice seasoning 57
 cake pan 137
 Camembert 86
 can opener 129, 162
 Canadian bacon 91
 canary melon 49
 candy thermometer 133
 canisters 109
 canned goods 11
 cannelloni 73
 cantaloupe 48
 cap 146
 capon 90
 carafe 165
 carambola 53
 caraway 55
 cardamom 55
 cardoon 25
 carp 104
 carrot 34

cartilaginous fishes 101
 carton 111
 carving fork 128
 carving knife 127
 casaba melon 48
 cashew 44
 cassava 21
 cauliflower 30
 cayenne chile 56
 celeriac 35
 celery 25
 celtnuce 26
 cereal 64
 cereal products 66
 chamomile 76
 champagne flute 115
 chanterelle 17
 chapati bread 69
 chard 23
 charlotte mold 137
 chayote 33
 check 15
 checkouts 11
 cheese box 111
 cheese counter 11
 cheese grater, rotary 131
 cheese knife 125
 cheeses, blue-veined 85
 cheeses, fresh 83
 cheeses, goat's-milk 83
 cheeses, soft 86
 chef 14
 cherimoya 53
 cherry 41
 chervil 63
 chest freezer 154
 chestnut 45
 Chèvre cheese 83
 chick peas 37
 chicken 90
 chile 56
 chili powder 57
 chinois 134
 chipolata sausage 93
 chive 20
 chocolate 78
 chop 95, 96
 chorizo 92
 cinnamon 55
 citron 47
 citrus fruits 46
 citrus juicer 130, 150
 clam 99
 clean dish table 15
 cleaver 127
 clock timer 153
 clove 54
 coarse salt 60
 cockle 99

cocktail glass 115
 cocoa 78
 coconut 45
 coffee 76
 coffee beans 76
 coffee maker 165
 coffee makers 165
 coffee mill 164
 coffee mug 116
 coffee spoon 123
 cola nut 44
 colander 134
 cold storage chamber 10
 collards 27
 common periwinkle 99
 common pllice 107
 conchiglie 72
 condiments 58
 container 146
 control button 146
 control panel 153, 157
 convenience food 11
 cook's knife 127
 cooked ham 91
 cookie cutters 135
 cooking dishes 160
 cooking plate 158
 cooking surface 158, 159
 cooking unit 152
 cooking utensils 141
 cooktop 112, 152
 coriander 63
 corkscrew 129
 corn 65
 corn bread 71
 corn flour 66
 corn oil 80
 corn salad 29
 corn syrup 79
 cottage cheese 83
 Coulommiers 86
 countertop 112
 couscous 66
 couscous kettle 144
 cover 164
 cowshed 9
 crab 100
 cracked bread 70
 cracked rye bread 70
 cranberry 43
 crank 131
 crate 100
 crayfish 109
 cream 81
 cream cheese 83
 cream cup 111
 creamer 116
 crispier 155
 croissant 68

crookneck squash 33
 crosne 21
 Crottin de Chavignol 83
 crushed chiles 56
 crustaceans 100
 cucumber 32
 cultivated mushroom 17
 cumin 55
 cup 110, 116
 cupped Pacific oyster 99
 curled endive 29
 curled kale 27
 currant 42
 currant tomato 31
 curry 55
 customers' cloakroom 13
 customers' toilets 13
 cuts of beef 94
 cuts of lamb 96
 cuts of pork 97
 cuts of veal 95
 cutting blade 146, 162
 cutting board 128
 cutting edge 124, 126
 cuttlefish 98

D

daikon 34
 dairy 9
 dairy compartment 155
 dairy products 10, 81
 dandelion 28
 Danish Blue 85
 Danish rye bread 70
 dark chocolate 78
 date 41
 decanter 115
 deep fryer 14, 156
 defrost drain 154
 delicatessen 10, 91
 delicious lactarius 16
 demitasse 116
 dessert fork 121
 dessert knife 125
 dessert spoon 123
 detachable control 159
 dible 145
 Dijon mustard 59
 dill 62
 dinette 113
 dining room 13
 dinner fork 121
 dinner knife 125
 dinner plate 117
 dinnerware 116
 dirty dish table 15
 dish 158
 dishwasher 15, 112
 ditali 72
 dolichos beans 38
 domestic appliances 146, 162
 door 153
 double boiler 145
 dough hook 149
 draining spoon 138

drawer 113
 dredger 136
 dried chiles 56
 drink box 111
 drinks 10
 drip pan 158
 tray 167
 dripping pan 143
 drive wheel 162
 drum 131
 dry fruits 44
 duck 90
 duck egg 87
 dulse 18
 durian 53
 Dutch oven 144

E

ear loaf 68
 edible boletus 16
 eel 103
 egg beater 135
 egg carton 109
 egg noodles 75
 egg poacher 144
 egg slicer 140
 egg timer 132
 eggplant 32
 eggs 87
 elbows 72
 electric grill, indoor 158
 electric range 14, 152
 electric steamer 160
 Emmenthal 84
 enclosure 9
 English loaf 71
 English mustard 59
 enoki mushroom 16
 escarole 26
 espresso coffee maker 166
 espresso machine 167
 evaporated milk 82
 examples of forks 121
 examples of kitchen knives 127
 examples of knives 125
 examples of spoons 123

F

fallow 8
 farmhouse 8
 farmhouse bread 71
 farmstead 8
 farmyard 8
 fats and oils 80
 feed tube 151, 163
 feijoa 53
 fence 8
 fennel 24
 fengreek 55
 fettucine 73
 fiddlehead fern 23
 fig 52
 filleting knife 127

filter holder 167
 fish fork 121
 fish knife 125
 fish platter 118
 fish poacher 141
 fishes, bony 102
 fishes, cartilaginous 101
 five spice powder 57
 flageolet 40
 flat oyster 99
 flour 66
 fodder corn 9
 foie gras 91
 foil, aluminum 108
 fondue fork 121
 fondue pot 142
 fondue set 142
 food 8
 food and kitchen 8
 food can 110
 food mill 130
 food processor 151
 food tray 109
 footstool 113
 for opening 129
 fork 120
 forks, examples 121
 four blade beater 149
 frankfurter 93
 freezer 12, 113, 154
 freezer bag 108
 freezer bucket 164
 freezer compartment 155
 French bread 68
 fresh cheeses 83
 fresh meat counter 10
 frozen foods 11
 fruit tree 9
 fruit vegetables 31
 fruits 10, 41
 fruits, tropical 51
 fry basket 134
 frying pan 145
 funnel 134
 fusilli 72

G

gabletop 111
 Gai-lohn 30
 game 89
 garam masala 56
 garden cress 29
 garden sorrel 29
 garden, vegetable 8
 garlic 20
 garlic press 130
 gas range 14, 152
 Genoa salami 92
 German mustard 59
 German rye bread 70
 German salami 92
 ghee 81
 gherkin 32
 ginger 57

ginkgo nut 44
 glass bottle 110
 glassware 114
 gnocchi 72
 goat's milk 82
 goat's-milk cheeses 83
 goatfish 102
 gondola 11
 goose 90
 goose egg 87
 gooseberry 42
 Gorgonzola 85
 granulated sugar 79
 grape 43
 grape leaf 28
 grapefruit 47
 grapefruit knife 127
 grate 152
 grater 131
 gravy boat 119
 grease well 159
 great scallop 98
 Greek bread 68
 green bean 39
 green cabbage 27
 green coffee beans 76
 green onion 20
 green peas 37
 green pepper 54
 green russula 16
 green sweet pepper 31
 green tea 77
 greenhouse 9
 griddle 159
 groove 128
 ground beef 94
 ground lamb 96
 ground pepper 57
 ground pork 97
 ground veal 95
 Gruyère 84
 guard 126
 guava 52
 guinea fowl 89
 gurnard 103

H

haddock 106
 half handle 126
 halibut 107
 hallah 70
 ham knife 127
 hand blender 150
 hand mixer 148
 handle 120, 122, 124, 131, 148, 151, 156, 159, 161, 162, 164
 hard-shell clam 98
 hare 89
 harissa 60
 hayloft 8
 hazelnut 45
 head 25
 health and beauty care 11

heart 88
 heat-sealed film 110
 heel 126
 heel rest 148
 hen egg 87
 hen house 8
 herbal teas 76
 herbs 62
 herring 102
 highball glass 115
 hijiki 18
 hinge 161
 hive 9
 hock 97
 hoisin sauce 59
 homogenized milk 82
 honey 79
 honeydew melon 48
 hood 14
 horned melon 51
 hors d'oeuvre dish 118
 horseradish 34
 hot food table 14
 hot pepper 31
 hot plate 14
 household products 10
 hummus 58
 hyssop 63

I

ice cream freezer 164
 ice cream scoop 139
 ice cube dispenser 113
 ice machine 14
 iceberg lettuce 26
 icing syringe 135
 Indian chapati bread 69
 Indian naan bread 69
 indoor electric grill 158
 inflorescent vegetables 30
 insulations 76
 inside 122
 instant-read thermometer 133
 insulated handle 158
 Irish bread 71
 Irish moss 18
 island 113

J

jaboticaba 52
 jackfruit 51
 jalapeño chile 56
 Japanese persimmon 52
 Japanese plum 50
 Jarlsberg 84
 Jerusalem artichoke 22
 Jewish hallah 70
 jicama 21
 John dory 106
 juicer 163
 jubude 52
 juniper berry 54

K

kale 27
 ketchup 60
 kettle 162
 kidney 88
 kielbasa sausage 92
 kitchen 14, 108, 112
 kitchen knife 126
 kitchen knives, examples 127
 kitchen scale 133
 kitchen shears 140
 kitchen timer 132
 kitchen utensils 126
 kiwi 51
 knife 124
 knives, examples 125
 kohlrabi 24
 kombu 18
 kumquat 46

L

lablab bean 38
 ladle 138
 lamb cubes 96
 lamb, cuts 96
 lamprey 103
 lard 80
 larding needle 139
 larger spotted dogfish 101
 lasagna 73
 latch 153
 leaf 23
 leaf lettuce 26
 leaf vegetables 26
 leek 19
 legumes 36
 lemon 46
 lemon balm 63
 lentils 36
 lettuce 26
 lever 159
 lever corkscrew 129
 lid 141, 151, 154, 156, 157, 161, 163, 164, 165
 Lima bean 39
 lime 46
 limpet 99
 linden 76
 liqueur glass 114
 litchi 52
 liver 88
 loaf pan 157
 lobster 100
 lock 154
 loin chop 97
 longan 51
 lovage 63
 lower bowl 168
 lupine 36

M

macadamia nut 44
 machinery shed 8
 mackerel 103
 magnetic lid holder 162
 maitre d'hôtel 13
 malanga 35

malt vinegar 61
 mandarin 46
 mandoline 130
 mango 53
 mango chutney 60
 mangosteen 51
 maple syrup 79
 margarine 80
 marinade spices 57
 marrow 88
 meadow 9
 measuring beaker 132
 measuring cup 132
 measuring cups 132
 measuring spoons 132
 meat 94
 meat grinder 131
 meat keeper 155
 meat thermometer 133
 melon 49
 melon baller 139
 melons 48
 menu 15
 merguez sausage 93
 mesh bag 109
 mesh strainer 134
 microwave oven 113, 153
 milk 82
 milk chocolate 78
 milk cup 111
 millet 65
 mint 62
 mixing bowl 147
 mixing bowls 136
 molasses 79
 mollusks 98
 monkfish 105
 morel 16
 mortadella 92
 mortar 130
 motor unit 146, 150, 151, 163, 164
 mozzarella 83
 muffin pan 136
 mullet 104
 multigrain bread 71
 multipack 110
 mung bean 39
 Munster 86
 mushrooms 16
 muskmelon 48
 muslin 134
 mussel 99
 mustard 59

N

naan bread 69
 Neapolitan coffee maker 166
 neck 120, 122
 nectarine 41
 nettle 28
 noodles 74
 nori 18
 nut 44
 nutcracker 130
 nutmeg 55
 nutmeg grater 130

O

oat flour 66
 oats 64
 octopus 98
 office 12
 Ogen melon 49
 okra 31
 old-fashioned glass 115
 olive 31
 olive oil 80
 on-off button 164
 on-off switch 162, 165, 167
 onion 19
 oolong tea 77
 open crate 109
 opening, utensils 129
 orange 46
 orchard 9
 oregano 62
 ornamental kale 26
 ornamental tree 8
 ostrich egg 87
 oven 14, 112, 152
 oven thermometer 133
 oyster 99
 oyster fork 121
 oyster knife 128
 oyster mushroom 17

P

Pacific salmon 107
 package 110
 packaging 108
 packaging products 10
 pak-choi 28
 pancake pan 145
 pancetta 91
 pantry 113
 papaya 53
 paprika 56
 parboiled rice 67
 parchment paper 108
 paring knife 127
 Parmesan 84
 parsley 63
 parsnip 34
 passion fruit 52
 pasta 72
 pasta maker 131
 pastry bag and nozzles 135
 pastry blender 136
 pastry brush 135
 pastry cutting wheel 135
 patio door 112
 pattypan squash 33
 pe-t'ai 28
 peach 41
 peanut 36
 peanut oil 80
 pear 50
 peas 37
 pecan nut 44
 peeler 128
 penne 73

pepino 53
 pepper shaker 118
 pepperoni 92
 perch 104
 percolator 168
 periwinkle 99
 permanent pasture 8
 pestle 130
 pet food 11
 pheasant 89
 pheasant egg 87
 phyllo dough 69
 pickling onion 19
 pie pan 137
 piezo lever 162
 pigeon 89
 pigsty 9
 pike 104
 pike perch 105
 pine nut 44
 pineapple 51
 pink pepper 54
 pinto bean 39
 pistachio nut 44
 pita bread 69
 plaice 107
 plantain 51
 plastic film 108
 plate 161
 platter 118
 plum 41
 plum sauce 60
 plunger 166
 point 120, 126
 pome fruits 50
 poppy seeds 57
 Pont-l'Évêque 86
 pork, cuts 97
 port glass 114
 pot-and-pan sink 14
 potato 22
 potato masher 138
 pouch 108
 poultry 90
 poultry shears 140
 powdered milk 82
 powdered mustard 59
 powdered sugar 79
 prepared foods 11
 prerinse sink 15
 pressed cheeses 84
 pressure cooker 142
 pressure regulator 142
 prickly pear 53
 prosciutto 91
 pull tab 110
 pumpernickel 70
 pumpkin 33
 purslane 136
 pusher 131, 163

Q

quail 89
 quail egg 87
 quiche plate 137
 quince 50
 quinoa 65

R

rabbit 89
 rack 141
 Raclette 84
 raclette with grill 158
 radicchio 26
 radish 34
 rambutan 52
 ramekin 119
 range hood 112
 ras el hanout 57
 raspberry 43
 ravioli 73
 razor clam 99
 reach-in freezer 10
 reamer 150
 red cabbage 20
 red kidney bean 47
 red onion 19
 red sweet pepper 31
 red whortleberry 42
 redfish 106
 refrigerated display case 13
 refrigerator 12, 113, 155
 refrigerator compartment 155
 refrigerators 12
 removable-bottomed pan 137
 reservoir 165
 restaurant 12
 rib 23
 rib roast 94
 rice 64, 67
 rice noodles 74
 rice papers 75
 rice vermicelli 75
 rice vinegar 61
 ricotta 83
 rigatoni 72
 rilletes 91
 rim soup bowl 117
 rivet 126
 rock 95, 96, 97
 roasted coffee beans 76
 roasting pans 143
 rock candy 79
 rolling pin 136
 romaine lettuce 26
 roman bean 39
 Romano 84
 root 120
 root vegetables 34
 Roquefort 85
 rosemary 63
 rotary cheese grater 131
 rotini 72
 royal agaric 16
 Russian pumpernickel 70
 rutabaga 35
 rye 64
 rye bread 68

S

safety valve 142
 saffron 55
 sage 62
 salad bowl 119
 salad dish 119
 salad fork 121
 salad plate 117
 salad spinner 134
 salami 92
 salmon, Atlantic 107
 salmon, Pacific 107
 salsify 34
 salt 60
 salt shaker 118
 sambal oelek 60
 sapodilla 52
 sardine 102
 saucepan 145
 sausage 93
 sauté pan 145
 savory 63
 savoy cabbage 27
 scallion 20
 scallop 98
 scampi 100
 Scandinavian cracked bread 70
 scarlet runner bean 39
 screw cap 110
 sea bass 105
 sea bream 102
 sea kale 27
 sea lettuce 18
 sea salt 60
 seafood 11
 seaweed 18
 seedless cucumber 32
 self-service meat counter 10
 semolina 66
 service table 13
 sesame oil 80
 set of utensils 138
 shad 104
 shallot 20
 shank 94, 95, 96
 sharpening steel 128
 sharpening stone 128
 sheep shelter 9
 shiitake mushroom 17
 shopping carts 11
 shortening 80
 shrimp 100
 side 124
 sieve 134
 sifter 135
 signal lamp 156, 160, 162, 165, 168

silverware 120
 sink 112
 skate 101
 skimmer 138
 slot 120, 159
 small carton 111
 small crate 109
 small decanter 115
 small open crate 109
 small saucepan 145
 smelt 102
 smoked ham 97
 smooth hound 101
 snail 99
 snail dish 140
 snail tongs 140
 soba noodles 74
 soft cheeses 86
 soft shell clam 98
 sole 107
 somen noodles 74
 soufflé dish 137
 soup bowl 117
 soup spoon 123
 soup tureen 119
 sour cream 81
 soy sauce 59
 soybean sprouts 40
 soybeans 40
 spaghetti 73
 spaghetti squash 33
 spaghetti tongs 140
 spaghettini 73
 sparebites 97
 sparkling wine glass 114
 spatula 138
 spear 23
 speed control 147
 speed selector 148
 spelt wheat 64
 spices 54
 spinach 29
 spinach tagliatelle 73
 spindle 151
 spiny lobster 100
 spiral beater 149
 spirulina 18
 split peas 37
 spoon 122
 spoons, examples 123
 spout 162, 168
 squash 32
 squid 98
 staff cloakroom 12
 stalk 24
 stalk vegetables 23
 stand 142, 147
 station chef 14

steak 94, 95
 steak knife 125
 steam control knob 167
 steam nozzle 167
 steamer 144
 steamer basket 144
 stem 168
 Stilton 85
 stock pot 144
 stone fruits 41
 stoner 139
 store room 12
 straightneck squash 33
 strainer 150, 163
 straw 111
 strawberry 43
 sturgeon 101
 sugar 79
 sugar bowl 116
 sumac 57
 summer squash 32
 sundae spoon 123
 sunflower-seed oil 80
 supermarket 10
 sweet bay 62
 sweet peas 37
 sweet pepper 31
 sweet potato 22
 sweetbreads 88
 Swiss chard 23
 swordfish 102

T

Tabasco® sauce 58
 table mixer 147
 table salt 60
 tablespoon 123
 tagliatelle 73
 tahini 58
 tajine 142
 tamarillo 51
 tamarind paste 58
 tamper 167
 tang 124, 126
 taro 21
 tarragon 62
 tasting spoon 139
 tea 77
 tea bag 77
 tea ball 140
 teapot 116
 teaspoon 123
 temperature control 154, 159
 temperature selector 161
 tenderloin roast 94
 terrine 143
 thermostat 156
 thyme 62

tilt-back head 147
 timer 156, 160
 tine 120
 tip 23, 122, 124
 toaster 159
 tomato 31
 tomato coulis 58
 tomato paste 58
 tongs 140
 tongue 88
 tortellini 72
 tortilla 69
 Toulouse sausage 93
 tower silo 9
 tripe 88
 triticale 65
 tropical fruits 51
 trout 106
 truffle 17
 trussing needle 139
 tube 110
 tuber vegetables 21
 tuna 105
 turbot 107
 turkey 90
 turmeric 55
 turner 138
 turnip 35
 turntable 147

U

udon noodles 74
 unbleached flour 66
 unleavened bread 69
 upper bowl 168
 utensils, kitchen 126
 utensils, set 138

V

vacuum coffee maker 168
 vanilla extract 58
 variety meat 88
 veal cubes 95
 vegetable bowl 118
 vegetable brush 139
 vegetable garden 8
 vegetables 10, 19
 vegetables, bulb 19
 vegetables, fruit 31
 vegetables, inflorescent 30
 vegetables, leaf 26
 vegetables, root 34
 vegetables, stalk 23
 vegetables, tuber 21
 verben 76
 vermicelli 75

W

waffle iron 161
 waiter 14
 wakame 18
 wall cabinet 113
 walnut 45
 warming plate 165
 wasabi 60
 water chestnut 20
 water dispenser 155
 water goblet 115
 water level 165
 water level indicator 160
 water pitcher 119
 water tank 167
 watercress 28
 watermelon 49
 wax bean 39
 wax gourd 32
 window paper 108
 wheat 64
 wheel 99
 whipping cream 81
 whisk 135
 white bread 71
 white cabbage 27
 white chocolate 78
 white mustard 54
 white onion 19
 white pepper 54
 white rice 67
 white wine glass 114
 whitening 106
 whole-wheat flour 66
 wholegrain mustard 59
 wholemeal bread 71
 wild rice 64
 window 153, 157
 wine 10
 wine cellar 12
 wine list 15
 wine steward 13
 wine vinegar 61
 wine waiter corkscrew 129
 wire beater 149
 wok 141
 wok set 141
 won ton skins 75
 wood ear 17
 Worcestershire sauce 58
 work top 14

Y

yam 22
 yard-long bean 38
 yellow onion 19
 yellow sweet pepper 31
 yogurt 81

Z

zester 128
 zucchini 32

FOOD &
KITCHEN



Adapted from the famous *Visual Dictionary*, an international bestseller with more than 8 million copies sold, this new series of thematic and ultracompact books provides readers with a multitude of words and concepts that are encountered in everyday life.

All the subjects are explained with highly realistic illustrations, accompanied by terminology and concise definitions produced by an experienced group of professionals.

The Visual Dictionary of Food and Kitchen gives readers the opportunity to discover foodstuffs from all around the world and to familiarize themselves with tools used to prepare, preserve or eat food.

Convenient and affordable, this book is the perfect tool to expand your knowledge of the fascinating universe of food and kitchen!

