

June 1956 • 35 Cents

Astounding SCIENCE FICTION®



PLUS X

By ERIC FRANK RUSSELL

THE WORLD OF TOMORROW

... Waits for You in the Coming Issues of

ASTOUNDING SCIENCE FICTION

Here, in the magazine you know so well will be ...

- Complete Novelettes
- A wealth of special features
- Full-length serials • Unusual articles
- Choice Short Stories by Outstanding

Science Fiction Authors

For adventures beyond the realm of your immediate horizon, *read*

ASTOUNDING SCIENCE FICTION

Subscribe Now

You can enter a subscription to ASTOUNDING SCIENCE FICTION for 12 issues for only \$3.50

You save 70¢ compared with the newsstand rate of \$4.20 for the same 12 issues

FILL OUT AND MAIL ORDER FORM BELOW

Subscription Department, ASTOUNDING SCIENCE FICTION

304 East 45th Street, New York 17, N. Y.

Enter my subscription to ASTOUNDING SCIENCE FICTION for 12 issues at \$3.50.

I enclose payment in full

Check Money Order Cash New Subscription Renewal

Name _____

Address _____

City _____ Zone _____ State _____

Start my subscription with the _____ issue. ASF-6-56
U. S. and Possessions only

Astounding SCIENCE FICTION

VOLUME LVII • NUMBER 4

June 1956

Novelettes

- Plus X *Eric Frank Russell* 6
The Chosen People *Robert Randall* 73

Short Stories

- The Peasant Girl *Paul Janvier* 54
The Live Coward *Poul Anderson* 109
Sea Change *Thomas N. Scortia* 130

Articles

- Artistic Detail 53
Psionic Machine—Type One *John W. Campbell, Jr.* 97

Readers' Departments

- The Editor's Page 4
The Analytical Library 72
In Times to Come 96
The Reference Library *P. Schuyler Miller* 141
Brass Tacks 151

Editor: JOHN W. CAMPBELL, JR.

Assistant Editor: KAY TARRANT

Advertising Director: ROBERT E. PARK

Advertising Manager: WALTER J. McBRIDE

COVER BY FREAS • SYMBOL: *The Modern Demonology*

Illustrations by *Freas and van Dongen*

The editorial contents have not been published before, are protected by copyright and cannot be reprinted without publisher's permission. All stories in this magazine are fiction. No actual persons are designated by name or character. Any similarity is coincidental.

Astounding SCIENCE FICTION published monthly by Street & Smith Publications, Incorporated at 575 Madison Avenue, New York 22, N. Y. Arthur Z. Gray, President; Ralph R. Whittaker, Jr., Executive Vice-President; Arthur P. Lawler, Vice-President and Secretary; Thomas H. Kaiser, Treasurer. © 1956 by Street & Smith Publications, Inc., in the United States and countries signatory to the Berne Convention and Pan American Convention. Entered as Second-Class matter at the Post Office, New York, N. Y. Subscription \$3.50 for one year and \$6.00 for two years in United States, Possessions and Canada; \$4.75 for one year and \$8.00 for two years in Pan American Union, Philippine Islands and Spain. Elsewhere \$5.00 for one year and \$8.50 for two years. When possible allow four weeks for change of address. Give old address and new address when notifying us. We cannot accept responsibility for unsolicited manuscripts or art work. Any material submitted must include return postage. All subscriptions should be addressed to Subscription Dept., Street & Smith Publications, Incorporated, 304 East 45th Street, New York 17, New York.

\$3.50 per Year in U. S. A.

Printed in  173 the U. S. A.

35 cents per Copy

• NEXT ISSUE ON SALE JUNE 19, 1956 •

THE PROBLEM OF PSIONICS

The reader vote on the question of whether we should run psionics articles was overwhelmingly "yes!" The first articles appear in this issue.

There are a number of problems to be solved, however; first, of course, is the matter of getting articles at all. I will need the help of readers all over the world to do it; there is no channel of communication in existence, now, by which the individual, scattered workers in the field can be found. To hear about the work being done, I'll have to have the help of individual readers, who are scattered as widely as the psionic workers themselves. It'll have to be a matter of "I happen to know a man who's—"

Second, the policy applied to selection of articles must be considered. A number of readers made very sound suggestions on that, and they'll be

considered. The problem, however, is that difficult business of selecting the sound from the unsound—when there are no experts in the field to judge them. There *are* no psionic experts; no one is competent, then, to select.

This problem ties in with another item; many readers suggested that we should start a Journal of Psionics.

No; definitely inappropriate.

To do so at this point in the development would be presumptuous—and would, in fact, cripple the development of the field. It's nice, of course, to have professional status, and have a professional journal, and not be mere amateurs. But a lot of semi-developed could-become-sciences have eagerly leaped into full claimed professional status—which cost them their amateur status, and led to a rigid freezing of half-developed theories as Professional

Orthodoxy. The professional can't experiment freely; he has to be orthodox. If the Professional Orthodoxy got itself frozen while in half-baked, amateurish condition—there's trouble for that could-be-science for years and years to come.

Psionics isn't ready for any kind of a journal; when it first becomes competent to have some sort of magazine, it should be on the order of *CQ*, or *QST*, the *amateur* radio magazines.

The reason is simple: an amateur journal does not profess to be authoritative; it offers mainly "I tried this, and it worked pretty darned good for my purposes." The amateur can describe a piece of equipment he built, and his theory may be as wacky as a phlogiston explanation of combustion—but that's O.K. The amateur's theory can afford to be screwball—if his gadget works. Nobody demands that an amateur be authoritative—simply that he be truthful as to components, structure, and results.

Friends, for years and years to come, psionics is going to be the least authoritative field you ever heard of. Any "authorities" that show up in the field should be firmly muzzled, bound, and heaved out into some place where authorities are possible. There are no experts; there aren't going to be any experts in your lifetime or mine. There aren't going to be any professionals competent to judge good articles. Nobody knows enough, and enough won't be known for *at least two solid centuries*.

Psionics is the field of human achievement beyond science. It took two thousand years to get science licked into a halfway decent shape. If you think a new field, at least as extensive as all of science, can be licked in your lifetime—straighten up and fly right, for Pete's sake! Don't be silly!

We're trying to crack the edge of something inherently enormously broader than all of science; our generation will be lucky to find one per cent of the number of fields within the great area, let alone finding all the things that lie in those fields.

So be it thoroughly understood that the articles we run are going to be exceedingly unauthoritative, untrustworthy, incoherent, and misinterpreted—as judged from the viewpoint of someone a century or so hence, who will know what it was we were striving for. (Take a look at the learned discussions of phlogiston, if you want a good estimate of about how far off the beam we can expect to be.)

The only sane thing we can do is say, mentally, "O.K.—so we're fumbling amateurs, and we don't know what we're talking about. But if it works, if it is useful at all, in any way, it's a worthwhile gimmick. And if it never does a darned thing of any practical value—fine. I've had fun trying!"

Of course, there's the other side. Somebody, somewhere along the line is going to come up with some breadboard contraption that negates grav-

(Continued on page 158)

PLUS X

Naturally, he wanted to escape the Aliens' prison. As it turned out, the Aliens would have been much better off if they'd just give him a few nuclear bombs, a spaceship, and let him go. He'd have done less damage that way...

BY ERIC FRANK RUSSELL

Illustrated by Freas

One thing was certain: he was out of the war. Perhaps for a long time to come or possibly for keeps—dead, maimed or a prisoner. The next few seconds would decide the manner of his exit from the fray.

The little ship made another crazy spin on its longitudinal axis. In the fore observation port the gray-green face of a planet swirled the opposite way. John Leeming's brains seemed to rotate in sympathy, causing momentary confusion. Behind the ship the distorted fire-trail shaped itself into an elongated spiral.

Ground came up fast, mere crinkles expanding into hills and valleys, surface fuzz swelling into massed trees. His straining eyes saw a cluster of rooftops turn upside down then swing right way round.

Choice needs time even if only the minimum required to make selection. When there's no time

there's no choice. Leeming's sole concern was to land the ship any place, anywhere, even slap in the middle of the foe, so long as it hit belly-down with nothing to oppose its forward skidding.

He made it either by sheer good luck or, more likely, happy absence of bad luck. A gentle upward slope magnified toward the nose at precisely the right moment. He maneuvered somehow, heaven alone knew how, dropped the damaged tail, cut power, struck dirt, slid halfway up the slope amid a twin spray of dust, sparks and grinding noises.

For half a minute he sat still and sweated while feeling peculiarly cold. Then he glanced at the atmospheric analyzer. It said the local air had nothing wrong with it.

Clambering through the lock, Leeming bolted to the tail end. He looked at the array of drivers and

found them a mess. Five tubes lacked linings and had warped under resulting heat. Four more were on the point of going cockeyed. He'd come in on the remaining seven and that was a feat verging on the miraculous.

Back home they'd warned him that the vessel might not stand up to the task imposed upon it. "We're giving you a special scout-boat with battleship tubes and improved linings. The ship is light and unarmed but fast and exceptionally long-ranged. Whether it will hold together over such a vast trip is something that can be determined only by actual test. Right now it's the best we can offer. In four or five years' time we may have one fifty times better. But we can't wait four or five years."

"I understand."

"So you'll be taking a risk, a big one. You may never return. All the same, we've got to learn what lies behind the enemy's spatial frontier, how deeply his authority extends, how far his hidden resources go. Somebody's got to stick out his neck to get that information. Somebody's got to wander loose behind the lines."

"I'm willing."

They'd patted his shoulder, given him a heavily escorted send-off that had taken him through the area of battle. Then, on his own, he'd slipped through a hostile frontier, a tiny, unstoppable speck in the immensity of space.

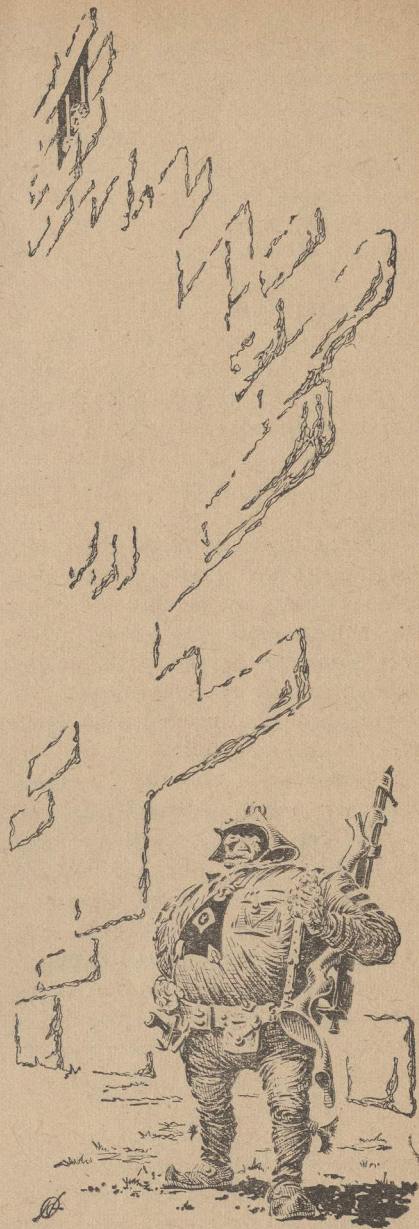

For weeks of which he'd lost count he had beamed data of all kinds, penetrating deeper and deeper into the starfield until the first tube blew a tormented and dessicated lining along the vapor-trail. Even as he turned belatedly for home the second one went. Then a third. After that, it was a matter of getting down in one piece on the nearest inhabitable hunk of plasma.

At the bottom of the slope, a thousand yards away, lay a large village stirred to active life by his overhead thunder and nearby landing. Already its small garrison was charging out, weapons in hand, heading for the ship.

Diving back through the lock, Leeming jerked a lever in the tiny control room, got out fast, raced up the slope, counting to himself as he ran. Down at the bottom the enemy troops paused in their advance, let go hoarse yells but failed to open fire.

"Sixty-nine, seventy!" gasped Leeming, and threw himself flat.

The ship flew apart with a mighty roar that shook the hills. Wind pressed powerfully in all directions. Shrapnel rained from the sky. A seven-pound lump of metal thumped to ground a yard from Leeming's head and he could not recognize it as any part of what once had arched past strange suns and unknown planets.

He stood up, saw that he now had the enemy on both sides. A thin line of armed figures had come over the crest of the slope. They had

weapons pointed his way and were gazing awestruck at the great crater halfway down.

At the bottom the troops from the village picked themselves up, having either thrown themselves flat or been blown flat. None appeared to be injured, none looked delighted either.

Leeming raised his arms in universal token of surrender. He felt bitter as he did it. Good luck followed by bad luck. If only the ship had hit ten miles farther back or ten farther on, he could have taken to the woods and played hard to get for weeks, months or, if necessary, years.

Anyway, this was the end of the trail.

The enemy came up fast. They were two-legged, on the short side, tremendously broad and powerful. Their gait was the typical stumping of squat, heavy men. Close up, they were seen to have scaly skins, horn-covered eyes, no eyelids. The first one to arrive made Leeming think of a sidewinder that somehow had taken on monkeylike shape.

Though obviously made jumpy by his forced landing and the big bang, they did not treat him with open antagonism. Their manner was suspicious and reserved. After a little reflection he guessed the reason for this. They'd seen nobody quite like him before, had no means of determining whether he was friend or foe, and temporarily were reserving judgment.

This was excusable. On Leeming's side of the battle was a federation of eighteen life forms, four of them human and five more very humanlike. Against these was an uneasy, precarious union of at least twenty life forms of which two were also very humanlike. Pending examination, this particular bunch of quasi-reptilians just couldn't tell enemy from ally. Neither did they know whether the ship's spectacular destruction was accidental or a piece of deliberate naughtiness.

Nevertheless they were taking no chances. Half a dozen kept him covered while an officer inspected the crater. The officer came back, favored Leeming with an unwinking stare, voiced an incomprehensible gabble. Leeming spread his hands and shrugged.

Accepting this lack of understanding as something that proved nothing one way or the other, the officer shouted commands at his troops. They formed up, marched to the village with the suspect in their midst.

Arriving, they shoved Leeming into the back room of a rock house with two guards for company, two more outside the door. He sat on a low, hard chair, sighed, stared blankly at the wall for two hours. The guards also sat, watched him as expressionlessly as a pair of snakes, and never said a word.

At the end of that time a trooper brought food and water. The meal tasted strange but proved satisfying. Leeming ate and drank in silence,

studied the wall for another two hours.

He could imagine what was going on while they kept him waiting. The officer would grab the telephone—or whatever they used in lieu thereof—and call the nearest garrison town. The highest ranker there would promptly transfer responsibility to military headquarters. A ten-star panjandrum would pass the query to the main beam station. An operator would then ask the two humanlike allies whether they'd lost track of a scout in this region.

If a signal came back saying, "No," the local toughies would realize that they'd caught a rare bird deep within their spatial empire and menacingly far from the area of conflict. If a thing can be either of two things, and it isn't one of them, it's got to be the other. Therefore if he wasn't a friend he had to be a foe despite his appearance where no foe had ever penetrated before.

When they learned the truth they weren't going to like it. Holding-troops far behind the lines share all the glory and little of the grief. They're happy to let it stay that way. A sudden intrusion of the enemy where he's no right to be is an event disturbing to the even tenor of life and not to be greeted with cries of martial joy. Besides, where one can sneak in a host of armies can follow and it is disconcerting to be taken in force from the rear.

What would they do to him when they identified him as a creature of

the Federation? He was far from sure, never having seen or heard of this especial life form before. One thing was probable: they'd refrain from shooting him out of hand. If sufficiently civilized, they'd imprison him for the duration of the war and that might mean for the rest of his natural life. If uncivilized, they'd bring in an ally able to talk Earth language and proceed to milk the prisoner of every item of information he possessed, by methods ruthless and bloody.

Back toward the dawn of history when conflicts had been Earth-wars there had existed a protective device known as the Geneva Convention. It had organized neutral inspection of prison camps, brought occasional letters from home, provided Red Cross parcels that had kept alive many a captive who otherwise would have died.

There was nothing like that today. A prisoner now had only two forms of protection, those being his own resources and the power of his side to retaliate against the prisoners they'd got. And the latter was a threat more potential than real. There cannot be retaliation without actual knowledge of maltreatment.

Leeming was still brooding over these matters when the guards were changed. Six hours had now dragged by. The one window showed that darkness was falling. He eyed the window furtively, decided that it would be suicidal to take a running jump at it under two guns. It was small and high.

A prisoner's first duty is to escape. That means biding one's time with appalling patience until occurs a chance that may be seized and exploited to the utmost. Or if no opportunity appears, one must be created—by brawn and brains, mostly the latter.

The prospect before him was tough indeed. And before long it was likely to look a deal tougher. The best moment in which to organize a successful getaway had come immediately after landing. If only he'd been able to talk the local language, he might have convinced them that black was white. With smooth, plausible words, unlimited self-assurance and just the right touch of arrogance he might have persuaded them to repair his boat and cheer him on his way, never suspecting that they had been argued into providing aid and comfort for the enemy.

Lack of ability to communicate had balled up that prospect at the start. You can't chivvy a sucker into donating his pants merely by making noises at him. Some other chance must now be watched for and grabbed, swiftly and with both hands—providing they were fools enough to permit a chance.

Which was most unlikely.

He remained in the house four days, eating and drinking at regular intervals, sleeping night-times, cogitating for hours, occasionally glowering at the impassive guards. Mentally he concocted, examined

and rejected a thousand ways of regaining freedom, most of them spectacular, fantastic and impossible.

At one time he went so far as to try to stare the guards into an hypnotic trance, gazing intently at them until his own eyeballs felt locked for keeps. It did not faze them in the least. They had the lizardlike ability to remain motionless and outstare him until kingdom come.

Mid-morning of the fourth day the officer strutted in, yelled, "*Amash! Amash!*" and gestured toward the door. His tone and attitude were both unfriendly. Evidently they'd received a signal defining the prisoner as a Federation space-louse.

Leeming got up from his seat and walked out, two guards ahead, two behind, the officer following. A steel-sheathed car waited in the road. They shoved him into it, locked it. Two guards stood on the rear platform, one joined the driver at front. The journey took thirteen hours which the inmate spent jolting around in complete darkness.

By the time the car halted Leeming had invented one new and exceedingly repulsive word. He used it as the rear doors opened.

"*Amash!*" bawled a guard, unappreciative of alien contributions to the vocabulary of invective.

With poor grace Leeming amashed. He glimpsed great walls rearing against the night and a zone of bright light high up before he was pushed through a metal portal into a large room. Here a reception com-

mittee of six thuglike samples awaited him. One of the six signed a paper presented by the escort. The guards withdrew, the door closed, the six eyed the visitor with lack of amiability.

One of them said something in an authoritative voice, made motions illustrative of undressing.

Leeming used the word.

It did him no good. The six grabbed him, stripped him naked, searched every vestige of his clothing, paying special attention to seams and linings. None showed the slightest interest in his alien physique despite that it stood fully revealed in the raw.

Everything he possessed was put to one side, pen, compass, knife, lighter, lucky piece, the whole lot. Then they shied his clothes back at him. He dressed himself while they pawed through the loot and gabbled together. They seemed slightly baffled and he guessed that they were surprised by his lack of anything resembling a lethal weapon.

Amid the litter was a two-ounce matchbox-sized camera that any ignorant bunch would have regarded with suspicion. It took the searchers a couple of minutes to discover what it was and how it worked. Evidently they weren't too backward.

Satisfied that the captive now owned nothing more dangerous than the somewhat bedraggled clothes in which he stood, they led him through the farther door, up a flight of thick stone stairs, along a stone corridor and into a cell. The door slammed

shut with a sound like the crack of doom.

In the dark of night four small stars winked and glittered through a heavily barred opening high up in one wall. Along the bottom of the gap shone a faint yellow glow from some outside illumination.

He fumbled around in the gloom, found a wooden bench against one wall. It moved when he lugged at it. Dragging it beneath the opening, he stood on it but found himself a couple of feet too low to gain a view. Though heavy, he struggled with it until he got it upended against the wall. Then he clambered up it, had a look between the bars.

Forty feet below lay a bare stone-floored space fifty yards wide and extending to the limited distance he could see in both directions. Beyond that, a smooth-surfaced stone wall rising to his own level. The top of the wall angled at about sixty degrees to form a sharp apex and ten inches above that ran a single line of taut wire, plain, without barbs.

From unseeable sources to the right and left poured powerful beams of light which flooded the entire area between cell and wall, also a similar area beyond the wall. Nothing moved. There was no sign of life. There was only the wall, the flares of light, the overhanging night and the distant stars.

"So I'm in the jug," he said. "That's torn it!"

He jumped to the invisible floor and the slight thrust of his feet made

the bench fall with a resounding crash. Feet raced along the outer passage, light poured through a suddenly opened spyhole in the heavy metal door. An eye appeared in the hole.

"*Sach invigia, faplap!*" shouted the guard.

Leeming used the word again and added six more, older, time-worn but still potent. The spyhole slammed shut. He lay on the bench and tried to sleep.

An hour later he kicked hell out of the door and when the spyhole opened he said, "Faplap yourself!"

After that, he did sleep.

Breakfast consisted of one lukewarm bowl of stewed grain resembling millet, and a mug of water. Both were served with disdain. Soon afterward a thin-lipped specimen arrived accompanied by two guards. With a long series of complicated gestures the newcomer explained that the prisoner was to learn a civilized language and, what was more, would learn it fast, by order. Education would commence forthwith.

In businesslike manner the tutor produced a stack of juvenile picture books and started the imparting process while the guards lounged against the wall and looked bored. Leeming co-operated as one does with the enemy, namely, by misunderstanding everything, mispronouncing everything, overlooking nothing that would prove him a linguistic moron.

The lesson ended at noon and

was celebrated by the arrival of another bowl of gruel containing a hunk of stringy, rubberish substance resembling the hind end of a rat. He ate the gruel, sucked the portion of animal, shoved the bowl aside.

Then he pondered the significance of their decision to teach him how to talk. Firstly, it meant that they'd got nothing resembling Earth's electronic brain-pryers and could extract information only by question-and-answer methods aided by unknown forms of persuasion. Secondly, they wanted to know things and intended to learn them if possible. Thirdly, the slower he was to gain fluency the longer it would be before they put him on the rack, if that was their intention.

His speculations ended when guards opened the door and called him out. Along the passage, down long stairs, into a great yard filled with figures mooching around under a sickly sun.

He halted in surprise. Rigellians! About two thousand of them. These were allies, members of the Federation. He looked them over with mounting excitement, seeking a few more familiar shapes amid the mob. Perhaps an Earthman or two. Or even a few humanlike Centaurians.

But there were none. Only rubberlimbed, pop-eyed Rigellians shuffling around in the aimless manner of those confronted with many wasted years and no perceivable future.

Even as he looked at them he

sensed something peculiar. They could see him just as well as he could see them and, being the only Earthman, he was a legitimate object of attention. He was a friend from another star. They should have been crowding up to him, full of talk, seeking the latest news of the war, asking questions, offering information.

They took no notice of him. He walked slowly and deliberately right across the yard and they got out of his way. A few eyed him furtively, the majority pretended to be unaware of his existence. Nobody offered him a word. They were giving him the conspicuous brush-off.

He trapped a small bunch of them in a corner of the wall and said, "Any of you speak Terran?"

They looked at the sky, the wall, the ground, or at each other, and remained silent.

"Anyone know Centaurian?"

No answer.

"Well, how about Cosmoglotta?"

No answer.

He walked away feeling riled, tried another bunch. No luck. And another bunch. No luck. Within an hour he had questioned five hundred without getting a single response.

Giving up, he sat on a stone step and watched them irefully until a shrill whistle signaled that exercise time was over. The Rigellians formed up in long lines in readiness to march back to their quarters. Leeming's guards gave him a kick in the pants and chivvied him to his cell.

Temporarily he dismissed the problem of unsociable allies. After dark was the time for thinking: he wanted to use remaining hours of light to study the picture books and get well ahead with the local lingo while appearing to lag far behind. Fluency might prove an advantage some day. Too bad he'd never learned Rigellian, for instance.

So he applied himself fully to the task until print and pictures ceased to be visible. He ate his evening portion of mush. After that he lay on the bench, closed his eyes, set his brains to work.

In all his life he'd met no more than a couple of dozen Rigellians. Never once had he visited their systems. What little he knew of them was hearsay evidence. It was said their standard of intelligence was good, they were technologically efficient, they had been consistently friendly toward men of Earth since first contact. Fifty per cent of them spoke Cosmoglotta, maybe one per cent knew the Terran tongue.

Therefore, if the average held up, several hundreds of those met in the yard should have been able to converse with him in one language or another. Why had they remained silent? And why had they been so unanimous about it?

He invented, examined and discarded a dozen theories. It was two hours before he hit upon the obvious solution.

These Rigellians were prisoners, deprived of liberty perhaps for years to come. Some of them must have

seen an Earthman at one time or another. But all of them knew that in the ranks of the foe were two races superficially humanlike. Therefore they suspected him of being a stooge, an ear of the enemy listening for plots.

That in turn meant something else. When a big mob of prisoners become excessively wary of a spy in their midst it's because they have something to hide. Yes, that was it! He slapped his knee in delight. The Rigellians had an escape plot in process of hatching and meanwhile were taking no chances.

How to get in on it?

Next day, at the end of exercise time, a guard administered the usual kick. Leeming upped and punched him clean on the snout. Four guards jumped in and gave the culprit a going over. They did it good and proper, in a way that no onlooking Rigellian could mistake for an act. It was an object lesson and intended as such. The limp body was carried upstairs with its face a mess of blood.

It was a week before Leeming was fit enough to reappear in the yard. His features were still an ugly sight. He strolled through the crowd, ignored as before, chose a spot in the sun and sat.

Soon afterward a prisoner sprawled tiredly on the ground a couple of yards away, watched distant guards and spoke in little more than a whisper.

"How'd you get here?"

Leeming told him.

"How's the war going on?"

"We're pushing them back slowly but surely. But it'll take time—a long time."

"How long do you suppose?"

"I don't know. It's anyone's guess." Leeming eyed him curiously. "What brought this crowd here?"

"We're colonists. We were advance parties, all male, planted on four new planets that were ours by right of discovery. Twelve thousand of us altogether." The Rigellian went silent a moment, looked carefully around. "They descended on us in force. That was two years ago. It was easy. We weren't prepared. We didn't even know a war was on."

"They grabbed the planets?"

"You bet they did. And laughed in our faces."

Leeming nodded understanding. Claim-jumping had been the original cause of the fracas now extending across a sizable slice of a galaxy. On one planet a colony had put up an heroic resistance and died to the last man. The sacrifice had fired a blaze of fury, the Federation had struck back and the war was on.

"Twelve thousand you said. Where are the others?"

"Scattered around in prisons like this one. You picked a choice dump in which to sit out the war. The enemy has made this his chief penal planet. It's far from the fighting front, unlikely ever to be discovered. The local life form isn't much good for space battles but plenty good

enough to hold what others have captured. They're throwing up big jails all over the world. If the war goes on long enough, the planet will get solid with Federation prisoners."

"So your mob has been here most of two years?"

"Yes."

"And done nothing about it?"

"Nothing much," agreed the Rigellian. "Just enough to get forty of us shot for trying."

"Sorry," said Leeming, sincerely.

"Don't let it bother you. I know how you feel. The first few weeks are the worst." He pointed surreptitiously toward a heavily built guard across the yard. "Few days ago that lying swine boasted that there are already two hundred thousand Federation prisoners on this planet. He said that by this time next year there'll be two million. I hope he never lives to see it."

"I'm getting out of here," said Leeming.

"How?"

"I don't know yet. But I'm getting out. I'm not going to just squat and rot." He waited expectantly, hoping for some comment about others feeling the same way he did, maybe some evasive mention of a coming break, a hint that he might be invited to join in.

The Rigellian stood up, murmured, "Well, I wish you luck. You'll need it aplenty!"

He ambled off. A whistle blew and the guards shouted, "*Merse,*

faplaps! Amash!" And that was that.

Over the next four weeks he had frequent conversations with the same Rigellian and about twenty others, picking up odd items of information but finding them peculiarly evasive whenever the subject of freedom came up.

He was having a concealed chat with one of them and asked, "Why does everyone insist on talking to me secretly and in whispers? The guards don't seem to care how much you yap to one another."

"You haven't been cross-examined yet. If in the meantime they notice we've had plenty to say to you, they will try to get out of you everything we've said—with particular reference to ideas on escape."

Leeming pounced on the lovely word. "Escape, that's all there is to live for right now. If anyone's thinking of making a bid, maybe I can help them and they can help me. I'm a competent space pilot and that fact is worth something."

The other cooled off at once. "Nothing doing."

"Why not?"

"We've been behind walls a long time. We've learned at bitter cost that escape attempts fail when too many know what is going on. Some planted spy betrays us. Or some selfish fool messes things up by pushing in at the wrong moment."

"I see."

"Imprisonment creates its own especial conventions," the Rigellian

went on. "And one we've established here is that an escape-plot is the exclusive property of those who thought it up and only they can make the attempt. Nobody else is told. Nobody else knows until the resulting hullabaloo starts going."

"So I'm strictly on my own?"

"Afraid so. You're on your own in any case. We're in dormitories, fifty to a room. You're in a cell all by yourself. You're in no position to help anyone with anything."

"I can darned well help myself," he retorted angrily.

And it was his turn to walk away.

He'd been there just thirteen weeks when the tutor handed him a metaphorical firecracker. Finishing a lesson, the tutor compressed thin lips, looked at him with severity.

"You are pleased to wear the cloak of idiocy. But I am not deceived. You are far more fluent than you pretend. I shall report to the Commandant that you will be ready for examination in seven days' time."

"How's that again?" asked Leeming, putting on a baffled frown.

"You heard what I said and you understood me."

Slam went the door. Came the gruel and a jaundiced lump of something unchewable. Exercise time followed.

"They're going to put me through the mill a week hence."

"Don't let them scare you," advised the Rigellian. "They'd as soon

kill you as spit in the sink. But one thing keeps them in check."

"What's that?"

"The Federation is holding prisoners, too."

"Yes, but what the Federation doesn't know it can't grieve over."

"There'll be more than grief for somebody if eventually the victor finds himself expected to exchange live prisoners for corpses."

"You've got a point there," agreed Leeming. "I could do with nine feet of rope to dangle suggestively in front of the Commandant."

"I could do with a very large bottle of *vitz* and a female to ruffle my hair," sighed the Rigellian.

The whistle again. More intensive study while daylight lasted. Another bowl of ersatz porridge. Darkness

and four small stars peeping through the barred slot high up.

He lay on the bench and produced thoughts like bubbles from a fountain. No place, positively no place is absolutely impregnable. Given brawn and brains and enough time there's always a way in or out. Escapees shot down as they bolted had chosen the wrong time and wrong place, or the right time and wrong place, or the right place at the wrong time. Or they'd neglected brawn in favor of brains, a common fault of the impatient. Or they'd neglected brains in favor of brawn, a fault of the reckless.

With eyes closed he carefully reviewed the situation. He was in a cell with rock walls of granite hardness at least four feet thick. The

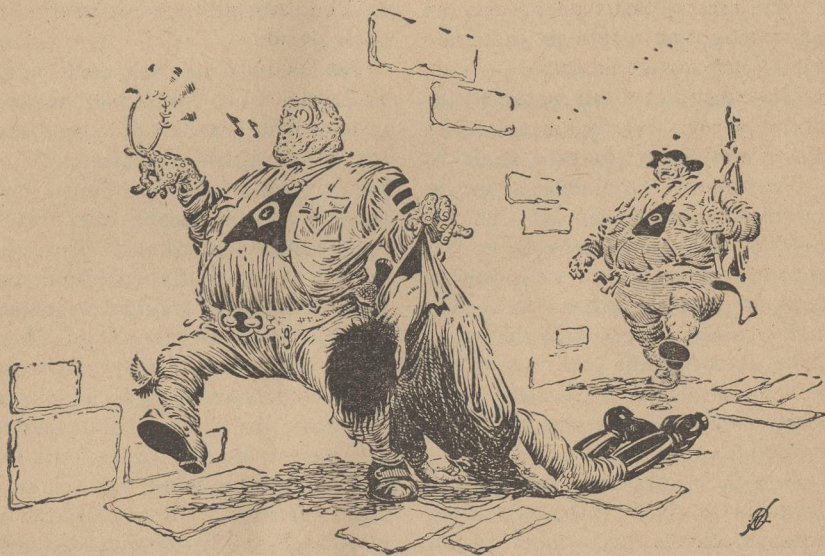

only openings were a narrow gap blocked by five thick steel bars, also an armor-plated door in constant view of patrolling guards.

On his person he had no hacksaw, no lock pick, no implement of any sort, nothing but the clothes in which he lay. If he pulled the bench to pieces, and somehow succeeded in doing it unheard, he'd acquire several large lumps of wood, a dozen six-inch nails and a couple of steel bolts. None of that junk would serve to open the door or cut the window bars before morning. And there was no other material available.

Outside was a brilliantly illuminated gap fifty yards wide that must be crossed to gain freedom. Then a smooth stone wall, forty feet high, devoid of handholds. Atop the wall an apex much too sharp to give grip to the feet while stepping over an alarm wire that would set the sirens going if touched or cut.

The wall completely encircled the entire prison. It was octagonal in shape and topped at each angle by a watchtower containing guards, machine guns, floodlights. To get out, the wall would have to be surmounted right under the noses of itchy-fingered watchers, in bright light, without touching the wire. That wouldn't be the end of it either; outside the wall was another illuminated fifty-yard area also to be crossed.

Yes, the whole set-up had the professional touch of those who knew what to do to keep them in for

keeps. Escape over the wall was well-nigh impossible though not completely so. If somebody got out of his cell or dormitory armed with a fifty-foot rope and grapnel, and if he had a confederate who could break into the prison's power room and switch off everything at exactly the right moment, he might make it. Over the dead, unresponsive alarm wire in total darkness.

In a solitary cell there is no fifty-foot rope, no grapnel, nothing capable of being adapted as either. There is no desperate and trustworthy confederate.

If he considered once the most remote possibilities and took stock of the minimum resources needed, he considered them a hundred times. By two o'clock in the morning he'd been beating his brains sufficiently hard to make them come up with anything, including ideas that were slightly mad.

For example: he could pull a plastic button from his jacket, swallow it and hope the result would get him a transfer to the hospital. True, the hospital was within the prison's confines but it might offer better opportunity for escape. Then he thought a second time, decided that a plastic blockage would not guarantee his removal elsewhere. There was a chance that they might be content to force a powerful purgative down his neck and thus add to his present discomforts.

As dawn broke he arrived at a final conclusion. Thirty, forty or fifty Rigellians, working in a patient,

determined group, might tunnel under the watched areas and the wall and get away. But he had one resource and one only. That was guile. There was nothing else he could employ.

He groaned to himself and complained, "So I'll have to use both my heads."

A couple of minutes later he sat up startled, gazed at the brightening sky and exclaimed, "Yes, sure, that's it! *Both* heads!"

By exercise time Leeming had decided that it would be helpful to have a gadget. A crucifix or a crystal ball provides psychological advantages. His gadget could be of any shape, size or design, made of any material, so long as it was obviously a contraption. Moreover, its potency would be greater if not made from items obtainable within his cell, such as parts of his clothing or pieces of the bench. Preferably it should be constructed of stuff from somewhere else.

He doubted whether the Rigelians could help. Six hours per day they slaved in the prison's workshops, a fate that he would share after he'd been questioned and his aptitudes defined. The Rigelians made military pants and jackets, harness and boots, a small range of engineering and electrical components. They detested producing for the enemy but their choice was a simple one: work or starve.

According to what he'd been told they had remote chance of smug-

gling out of the workshops anything really useful such as a knife, chisel, hammer or hacksaw blade. At the end of each work period the slaves were paraded and none allowed to break ranks until every machine had been checked, every loose tool accounted for and locked away.

The first fifteen minutes of the midday break he spent searching the yard for any loose item that might be turned to advantage. He wandered around with his gaze on the ground like a worried kid seeking a lost coin. The only things he found were a couple of pieces of wood four inches square by one inch thick. He slipped them into his pocket without having the vaguest notion of what he was going to do with them.

After that, he squatted by the wall, had a whispered chat with a couple of Rigelians. His mind wasn't on the conversation and the pair moved away when a patrolling guard came near. Later, another Rigelian mooched up.

"Earthman, you still going to get out of here?"

"You bet I am."

The Rigelian chuckled, scratched an ear, an action that his race used to express polite skepticism. "I think we've a better chance than you."

"Why?" Leeming shot him a sharp glance.

"There are more of us," evaded the other, as though realizing that he'd been on the point of saying too much. "What can one do on one's own?"

"Scoot like blazes first chance," said Leeming.

His eyes suddenly noticed the ring on the other's ear-scratching finger and became fascinated by it. He'd seen the modest ornament before, and dozens like it. A number of Rigellians were wearing similar objects. So were some of the guards. The rings were neat affairs consisting of four or five turns of thin wire with the ends shaped and soldered to form the owner's initials.

"Where'd you dig up the jewelry?" he asked.

"Eh?"

"The ring."

"Oh, that." The Rigellian lowered his hand, eyed the ring with satisfaction. "Make them ourselves in the workshops. It breaks the monotony."

"Mean to say the guards don't stop you?"

"They don't interfere. There's no harm in it. Anyway, we've made quite a number for the guards themselves. We've made them some automatic lighters as well. Could have turned out a few hundred for ourselves except that we've no use for them." He paused reflectively. "We think the guards have been selling rings and lighters outside. At least, we hope so."

"Why?"

"Maybe they'll build up a nice trade. Then, when they are comfortably settled in it, we'll cut supplies and demand a rake-off in the form of extra rations and a few unofficial privileges."

"That's smart of you," said Leem-

ing. "It would help all concerned to have a salesman traveling around the planet. Put me down for that job."

The Rigellian gave a faint smile, went on, "Hand-made junk doesn't matter. But let the guards find that one small screwdriver is missing and there's hell to pay. Everyone is stripped naked on the spot and the culprit suffers."

"They wouldn't miss a small coil of that wire, would they?"

"I doubt it. They don't bother to check the stuff. What can anyone do with a piece of wire?"

"Heaven knows," admitted Leeming. "But I want some."

"You'll never pick a lock with it in a million moons," warned the other. "It's too thin and too soft."

"I want enough to make a set of Zulu bangles," Leeming told him. "I sort of fancy myself in Zulu bangles."

"You can steal some wire yourself in the near future. After you've been questioned they'll send you to the workshops."

"I want it before then. I want it just as soon as I can get it."

Going silent, the Rigellian thought it over, finally said, "If you've a plan in your mind, keep it to yourself. Don't give a hint of it to anyone. Let anything slip and somebody will try to beat you to it."

"Thanks for the advice, friend," said Leeming. "How about a bit of wire?"

"See you this time tomorrow."

The Rigellian left him, wandered into the crowd.

The wire proved to be a small pocket-sized coil of tinned copper. When unrolled in the darkness of the cell it measured his own length, namely, six feet.

Leeming doubled it, waggled it to and fro until it broke, hid one half under the bottom of the bench. Then he spent more than an hour worrying a loose nail out of the bench's end.

Finding one of the pieces of wood, he approximated its center, stamped the nail into it with his boot. Footsteps approached, he shoved the stuff out of sight, lay down just before the spyhole opened. The light flashed on, an eye looked in, somebody grunted. The light cut off, the spyhole shut.

Leeming resumed his task, twisting the nail one way and the other, pressing it with his boot from time to time, persevering until he had drilled a neat hole two-thirds the way through the wood.

Next, he took his half-length of wire, broke it into two unequal parts, shaped the shorter piece to form a loop with two legs three or four inches long. He tried to make the circle as nearly perfect as possible. The longer piece of wire he wound tightly around the loop so that it formed a close-fitting coil with legs matching those of the loop.

Climbing the bench to the window, he examined his handiwork in the glow from outside floodlights,

made a few minor adjustments and felt satisfied. After that, he used the nail to make on the edge of the bench two small nicks representing the exact diameter of the loop. He counted the number of turns the coil made around the loop. There were twenty-seven.

It was important to have these details because it was highly likely that he'd have to make a second gadget. If so, he must make it precisely the same. Once they noticed it, that very similarity might get the enemy bothered. When a plotter makes two things practically identical it's hard to resist the notion that he's up to something definite.

To complete his preparations, he chivvied the nail back into the place where it belonged. Sometime he'd need it again. He then forced the four legs of the coiled loop into the hole that he'd drilled, thus making the small piece of wood function as a stand. He now had a gadget, a doodad, a means to an end. He was the original inventor and sole owner of the Leeming Something-or-Other.

Certain chemical reactions take place only in the presence of a catalyst, like marriages legalized by the presence of a justice of the peace. Some equations can be solved only by the inclusion of an unknown quantity called X. If you haven't enough on the ball, you've got to add what's needed. If you require outside help that doesn't exist, you've got to invent it.

Whenever Man was unable to master his environment with his bare

hands, thought Leeming, the said environment got bullied or coerced into submission by Man plus X. That had been so from the beginning of time—Man plus a tool or a weapon.

But X did not have to be anything—concrete or solid, it did not have to be lethal or even visible. It could be a dream, an idea, an illusion, a bloody big thundering lie, just *anything*.

There was only one true test—whether it worked.

If it did, it was efficient.

Now to see.

There was no sense in using Ter-ran except perhaps as an incantation when one was necessary. Nobody here understood it; to them it was just an alien gabble. Besides, his delaying tactic of pretending to be slow to learn was no longer effective. They now knew he could speak the local lingo almost as well as they could themselves.

Holding the loop assembly in his left hand, he went to the door, applied his ear to the closed spyhole, listened for the sound of patrolling feet. It was twenty minutes before he heard the approaching squeak of military boots.

"Are you there?" he called, not too loudly but enough to be heard. "Are you there?"

Backing off, he lay on his belly on the floor and stood the loop six inches in front of his face.

"Are you there?"

The spyhole clicked open, the

light came on, a sour eye looked through.

Completely ignoring the watcher, and behaving with the air of one totally absorbed in his task, Leeming spoke through the coiled loop.

"Are you there?"

"What are you doing?" demanded the guard.

Leeming recognized the voice, decided that for once luck must be turning his way. This character, a chump named Marsin, knew enough to point a gun and fire it or, if unable to do so, yell for help. In all other matters he was not of the elite. In fact Marsin would have to think twice to pass muster as a half-wit.

"What are you doing there?" demanded Marsin, more loudly.

"Calling," said Leeming, apparently just waking up to the other's existence.

"Who are you calling?"

"Mind your own business," ordered Leeming, giving a nice display of impatience. He turned the loop another two degrees. "Are you there?"

"It is forbidden," insisted Marsin.

Leeming let go the loud sigh of one compelled to bear fools gladly. "What is forbidden?"

"To call."

"Don't be so flaming ignorant!" Leeming reproved. "My kind is *always* allowed to call. Where'd we be if we couldn't, eh?"

That got Marsin badly tangled. He knew nothing about Earthmen or what peculiar privileges they con-

sidered essential to life. Neither could he give a guess as to where they'd be without them.

Moreover, he dared not bust into the cell and put a stop to whatever was going on. An armed guard was prohibited from entering a cell by himself and that rule had been strict ever since a Rigellian had bopped one, snatched his gun and killed six while trying to make a break.

If he wanted to interfere, he'd have to go see the sergeant of the guard and demand that something be done to stop aliens making noises through loops. The sergeant was an unlovely character with a tendency to advertise personal histories all over the landscape. It was four o'clock in the morning, a time when the sergeant's liver malfunctioned most audibly. And lastly, he, Marsin, had proved himself a misbegotten faplap far too often.

"You will cease calling and go to sleep," said Marsin, with a touch of desperation, "or in the morning I shall report this matter to the officer of the day."

"Go ride a camel," Leeming invited. He turned the loop in the manner of one making careful adjustment. "Are you there?"

"I have warned you," Marsin persisted, his only visible eye popping at the loop.

"Fibble off!" roared Leeming.

Marsin shut the spyhole and fibbled off.

Leeming overslept as was inevitable after being up most of the

night. His awakening was rude. The door opened with a crash, three guards plunged in followed by an officer.

Without ceremony the prisoner was jerked off the bench, stripped and shoved into the corridor stark naked. The guards hunted thoroughly through the clothing while the officer minced around them watching.

Finding nothing in the clothes they started searching the cell. Right off one of them found the loop assembly and gave it to the officer who held it gingerly as though it were a bouquet suspected of being a bomb.

Another guard found the second piece of wood with his boot, kicked it aside and ignored it. They tapped the floor and the walls, seeking hollow sounds. They dragged the bench from the wall and looked over the other side of it. Then they were about to turn the bench upside-down when Leeming decided that now was the time to take a walk. He started along the corridor, a picture of nonchalant nudity.

The officer let go an outraged howl and pointed. The guards erupted from the cell, bawled orders to halt. A fourth guard appeared at the bend of the corridor, aimed his gun and scowled. Leeming turned and ambled back.

He stopped as he reached the officer who was now outside the cell and fuming with temper. Striking a modest pose, he said, "Look, September Morn."

It meant nothing to the other who held the loop under his nose and yelled, "What is this thing?"

"My property," said Leeming with naked dignity.

"You are not supposed to possess it. As a prisoner of war you are not allowed to have anything."

"Who says so?"

"I say so!" declared the officer, somewhat violently.

"Who're you?" inquired Leeming.

"By the Sword of Lamissim," swore the other, "I'll show you who I am! Guards, take him inside and—"

"You're not the boss," put in Leeming, impressively cocksure. "The Commandant is the boss here. I say so and he says so. If you want to dispute it, let's go ask him."

The guards hesitated, assumed expressions of chronic uncertainty. The officer was taken aback.

"Are you asserting that the Commandant has given permission for you to have this object?"

"I'm telling you he hasn't refused permission. Also that it isn't for you to give it or refuse it."

"I shall consult the Commandant about this," the officer decided, deflated and a little unsure of himself. He turned to the guards. "Put the prisoner back in the cell and give him his breakfast as usual."

"How about returning my property?" Leeming prompted.

"Not until I have seen the Commandant."

They hustled him into the cell. He

got dressed. Breakfast came, the inevitable bowl of slop. He cursed the guards for not making it bacon and eggs. That was deliberate. A display of self-assurance and some aggressiveness was necessary to push the game along.

The tutor did not appear so he spent the morning furbishing his fluency with the aid of the books. At midday they let him into the yard and there was no evidence of an especial watch being kept upon him while there.

The Rigellian whispered, "I got the opportunity to swipe another coil. So I took it in case you wanted more." He slipped it across, saw it vanish into a pocket. "That's all I intend to take. Don't ask me again."

"What's up? Is it getting risky? Are they suspicious of you?"

"Everything is all right so far." He glanced warily around. "If some of the other prisoners get to know I'm taking it, they'll start grabbing it, too. They'll steal it in the hope of discovering what I'm going to use it for, so that they can use it for the same purpose. Everybody's always on the lookout for an advantage, real or imaginary, which he can share. This prison life brings out the worst as well as the best."

"I see."

"A couple of small coils will never be missed," the other went on. "But once the rush starts the stuff will evaporate in wholesale quantities. That's when all hell will break

loose. I daren't chance starting anything like that."

"Meaning you fellows can't risk a detailed search just now?" suggested Leeming pointedly.

The Rigellian shied like a frightened horse. "I didn't say that."

"I can put two and two together same as anyone else." Leeming favored him with a reassuring wink. "I can also keep my trap shut."

He explored the yard seeking more pieces of wood but failed to find any. Oh, well, no matter. At a pinch he could do without. Come to that, he'd darned well have to do without.

The afternoon was given over to further studies. When light became too poor for that, and first faint flickers of starlight showed through the barred opening in the wall, he kicked the door until the sound of it thundered all over the block.

Feet came running and the spyhole opened. It was Marsin again.

"So it's you," greeted Leeming. He let go a snort. "You had to blab, of course. You had to curry favor by telling the officer." He drew himself up to full height. "Well, I am sorry for you. I'd fifty times rather be me than you."

"Sorry for me?" Marsin registered confusion. "Why?"

"You are going to suffer. Not yet, of course. It is necessary for you to undergo the normal period of horrid anticipation. But eventually you are going to suffer."

"It was my duty," explained Marsin, semiapologetically.

"That fact will be considered in mitigation," Leeming assured, "and your agonies will be modified in due proportion."

"I don't understand," said Marsin, developing a node of worry somewhere within the solid bone.

"You will—some dire day. So also will those four stinking faplaps who beat me up. You can inform them from me that their quota of pain is being arranged."

"I am not supposed to talk to you," said Marsin, dimly perceiving that the longer he stood there the bigger the fix he got into. He made to close the spyhole.

"All right. But I want something."

"What is it?"

"I want my bopamagilvie—that thing the officer took away."

"You cannot have it until the Commandant gives permission. He is absent today and will not return before tomorrow morning."

"That's no use. I want it now." He gave an airy wave of his hand. "Never mind. Forget it. I will summon another one."

"It is forbidden," reminded Marsin, very feebly.

"Ha-ha!" said Leeming, venting a hearty laugh.

Waiting for darkness to grow complete, he got the wire from under the bench and manufactured a second whatzit to all intents and purposes identical with the first one.

Twice he was interrupted but not caught.

That job finished, he upended the bench and climbed it. Taking the new coil of wire from his pocket, he tied one end tightly around the bottom of the middle bar, hung the coil outside the window gap.

With spit and dust he camouflaged the bright tin surface of the one visible strand, made sure it could not be seen at farther than nose-tip distance. He got down, replaced the bench. The window gap was so high that all of its ledge and the bottom three inches of its bar

could not be viewed from below.

Going to the door, he listened and at the right time called, "Are you there?"

When the light came on and the spyhole was in use he got an instinctive feeling that there was a bunch of them clustered outside, also that the eye in the hole was not Marsin's.

Ignoring everything, he rotated the loop slowly and carefully, meanwhile calling, "Are you there?"

After traversing about forty degrees he paused, gave his voice a tone of intense satisfaction, said, "So

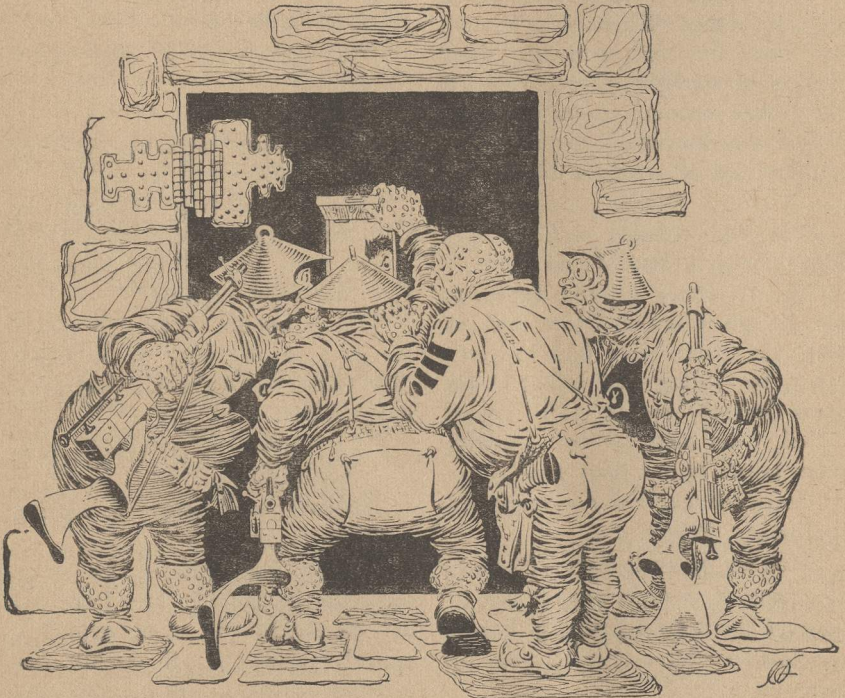

you are there at last! Why the devil don't you keep within easy reach so's we can talk without me having to summon you with a loop?"

He went silent, put on the expression of one who listens intently. The eye in the hole widened, got shoved away, was replaced by another.

"Well," said Leeming, settling himself down for a cozy gossip, "I'll point them out to you first chance I get and leave you to deal with them as you think fit. Let's switch to our own language—there are too many big ears around for my liking." He took a long, deep breath, rattled off at top pace and without pause, "Out sprang the web and opened wide the mirror cracked from side to side the curse has come upon me cried the Lady of—"

Out sprang the door and opened wide and two guards almost fell headlong into the cell in their eagerness to make a quick snatch. Two more posed outside with the officer between them. Marsin mooned fearfully in the background.

A guard grabbed up the loop assembly, yelled, "I've got it!" and rushed out. His companion followed. Both seemed hysterical with excitement.

There was a ten seconds' pause before the door shut. Leeming exploited the fact. He stood up, pointed at the group by making horizontal stabbing motions with his two middle fingers. Giving 'em the Devil's Horns they'd called it

when he was a kid. The classic gesture of donating the evil eye.

"Those," he declaimed dramatically, addressing what wasn't there, "are the scaly-skinned bums who've asked for trouble. See that they get plenty."

The whole bunch of them managed to look alarmed before the door cut them from sight with a vicious slam. He listened at the spy-hole, heard them go away muttering steadily between themselves.

Within ten minutes he had broken a length off the coil hanging from the window bars, restored the spit and dust disguise of the holding strand. Half an hour later he had another bopamagilvie. Practice was making him an expert in the swift and accurate manufacture of these things.

Lacking wood for a stand, he used the loose nail to bore a hole in the dirt between the big stone slabs composing the floor of his cell. He rammed the legs of the loop into the hole, twisted the contraption this way and that to make ceremonial rotation easy.

When the right moment arrived he lay on his belly and commenced reciting through the loop the third paragraph of Rule 27, subsection B, of Space Regulations. He chose it because it was a gem of bureaucratic phraseology, a single sentence one thousand words long meaning something known only to God.

"Where refueling must be carried out as an emergency measure at a station not officially listed as a home

station or definable for special purposes as a home station under Section A (5) amendment A (5) B the said station shall be treated as if it were definable as a home station under Section A (5) amendment A (5) B providing that the emergency falls within the authorized list of technical necessities as given in Section J (29-33) with addenda subsequent thereto as applicable to home stations where such are—”

The spyhole flipped open and shut. Somebody scooted away. A minute afterward the corridor shook to what sounded like a cavalry charge. The spyhole again opened and shut. The door crashed inward.

This time they reduced him to his bare pelt, searched his clothes, raked the cell from end to end. Their manner was that of those singularly lacking in brotherly love. They turned the bench upside-down, knocked it, tapped it, kicked it, did everything but run a large magnifying glass over it.

Watching this operation, Leeming encouraged them by giving a sinister snigger. Was a time when he could not have produced a sinister snigger even to win a fifty-credit bet. But he could do it now. The ways in which a man can rise to the occasion are without limit.

Giving him a look of sudden death and total destruction, a guard went out, brought back a ladder, mounted it, surveyed the window gap. It was a perfunctory glance, his mind being mostly concerned with the solidity of the bars. He grasped

each bar with both hands, shook vigorously. Satisfied, he got down, took the ladder away.

They departed. Leeming dressed himself, listened at the spyhole. Just a very faint hiss of breath and occasional rustle of clothes nearby. He sat on the bench and waited. In short time the lights flashed and the spyhole opened. He stabbed two fingers toward the inlooking eye.

The hole closed. Feet moved away stamping much too loudly. He waited. After half an hour of complete silence the eye offered itself again and for its pains received another two-fingered hex. Five minutes later it had another bestowed upon it. If it was the same eye all the time, it was a glutton for punishment.

This game continued for three hours before the eye had had enough. Then he made another loop, gabbled through it in a loud voice and precipitated another raid. They did not strip him or search the cell this time. They contented themselves with confiscating the gadget. And they showed signs of being more than somewhat fed up.

There was just enough wire left for one more. He decided to keep that against a future need and get some sleep. Inadequate food and not enough slumber were combining to make inroads on his reserves.

He flopped on the bench and closed red-rimmed eyes. In due time he started snoring fit to saw through the bars. That caused a panic in the passage, brought the crowd along in yet another rush.

Waking up, he damned them to perdition. He lay down again. He was plain bone-tuckered—but so were they.

He slept solidly until midday without a break except for the usual lousy breakfast. Soon after awakening came the usual lousy dinner. At exercise time they kept him locked in. He hammered on the door, demanded to know why he wasn't being allowed to walk in the yard. They took no notice.

So he sat on the bench and thought things over. Perhaps this denial of his only freedom was a form of retaliation for making them hop around like fleas in the middle of the night. Or perhaps the Rigelian was under suspicion and they'd decided to prevent contact.

Anyway, he'd got the enemy worried. He was bollixing them about, single-handed, far behind the lines. That was something. The fact that a combatant is a prisoner doesn't mean he's out of the battle. Even behind thick wire and high walls he can still harass the foe, absorbing his time and energy, undermining his morale, pinning down at least a few of his forces.

The next step, he decided, was to widen the hex. He must do it as comprehensively as possible. The more he spread it and the more ambiguous the terms in which he expressed it, the more plausibly he could grab the credit for any and every misfortune that was certain to occur sooner or later.

It was the technique of the gypsy's warning. People tend to attach specific meanings to ambiguities when circumstances arise and suggest a given meaning. People don't have to be especially credulous, either. It is sufficient for them to be made expectant, with a tendency to wonder—after the event.

"In the near future a dark, tall man will cross your path."

After which any male above average height, and not a blond, fits the picture. And any time from five minutes to a full year is accepted as the near future.

"Mamma, when the insurance man called he really smiled at me. *D'you remember what the gypsy said?*"

Leeming grinned to himself as his brain assembled facts and theories and analyzed the possibilities. Somewhere not so far away a bunch of Rigelians—or several bunches for all he knew—were deep in the earth and burrowing slowly, without tools. A few pitiful handfuls at a time. Progress at the rate of a couple of pathetic inches per night. Dirt taken out in mere pocket-loads and sprinkled through the yard. A constant, never-ending risk of discovery, entrapment and perhaps some insane shooting. A year-long project that could be terminated by a shout and the chatter of guns.

But to get out of clink you don't have to escape. If sufficiently patient, determined, glib and cunning you can talk the foe into opening the

doors and pushing you out. You can use the wits that God gave you.

By law of probability various things must happen in jail and out, and not all of them pleasing to the enemy. Some officer must get the galloping gripes right under his body-belt, or a guard must fall down a watchtower ladder and break a leg, somebody must lose a wad of money or his pants or his senses. Farther afield a bridge must collapse, or a train get derailed, or a spaceship crash at take-off, or there'd be an explosion in a munitions factory, or a military leader would drop dead.

He'd be playing a trump card if he could establish his claim to be the author of all misery. The essential thing was to stake it in such a way that they could not effectively combat it, neither could they exact retribution in a torture chamber.

The ideal strategy was to convince them of his malevolence in a manner that would equally convince them of their own impotence. If he succeeded, they'd come to the logical conclusion—that the only way to get rid of trouble was to get rid of Leeming, alive and in one piece.

It was a jumbo problem that would have appalled him way back home. But by now he'd had three months in which to incubate a solution—and the brain becomes stimulated by grim necessity. A good thing he had an idea in mind; he had a mere ten minutes before the time came to apply it.

The door opened, a trio of guards

glowered at him and one of them rasped, "The Commandant wishes to see you at once. *Amash!*"

The Commandant squatted behind a desk with a lower-ranking officer on either side. He was a heavily built specimen. His horn-covered lidless eyes gave him a dead-pan look as he studied the prisoner.

Leeming calmly sat himself in a handy chair and the officer on the right immediately bawled, "Federation garbage! You will stand in the presence of the Commandant."

"Let him sit," contradicted the Commandant.

A concession at the start, thought Leeming. He eyed the pile of papers on the desk. Ten to one the Commandant had read a complete report of his misdeeds and decided to reserve judgment until he'd got to the bottom of whatever was going on.

That attitude was natural enough. The Federation knew nothing of this local life form. By the same token the inquisitors knew nothing of several Federation forms, those of Earth in particular. From their viewpoint they were about to cope with an unknown quantity.

Man, how right they were! A quantity doubled by plus X.

"I am given to understand that you now speak our language," began the Commandant.

"No use denying it," Leeming confessed.

"Very well. You will first give some information concerning yourself." He positioned an official form

on his desk, held a pen in readiness.

"Name of planet of origin?"

"Earth."

The other wrote it phonetically in his own script, continued, "Name of race?"

"Terran."

"Name of species?"

"*Homo nosipaca*," said Leeming, keeping his face straight.

The Commandant wrote it down, looked doubtful, asked, "What does that mean?"

"Space-traversing Man," Leeming informed.

"Hm-m-m!" The other was impressed despite himself, inquired, "Your personal name?"

"John Leeming."

"John Leeming," repeated the Commandant, putting it down on the form.

"And Eustace Phenackertiban," added Leeming, airily.

That got written too, though the Commandant had some difficulty in finding hooks and curlicues to express Phenackertiban. Twice he asked Leeming to repeat it and that worthy obliged.

Studying the result, which resembled a Chinese recipe for rotten egg gumbo, the Commandant said, "It is your custom to have two names?"

"Most certainly," Leeming assured. "We can't avoid it seeing that there are two of us."

The listener twitched the eyebrows he lacked and showed mild surprise. "You mean that you are always conceived and born in pairs? Two identical males or females every time?"

"No, not at all." Leeming adopted the air of one about to state the obvious. "Whenever one of us is born he immediately acquires a Eustace."

"A Eustace?"

"Yes."

The Commandant frowned, picked his teeth, glanced at the other officers. They assumed the blank expressions of fellows who've come along merely to keep company.

"What," asked the Commandant at long last, "is a Eustace?"

Registering surprise at such ignorance, Leeming said, "An invisibility that is part of one's self."

Understanding dawned on the Commandant's scaly face. "Ah, you mean a soul? You give your soul a separate name?"

"Nothing of the sort," Leeming denied. "I have a soul and Eustace has a soul of his own." Then, as an afterthought, "At least, I hope we have."

The Commandant lay back and stared at him. There was quite a long silence.

Finally, he admitted, "I do not understand."

"In that case," announced Leeming, irritatingly triumphant, "it's evident that you have no alien equivalent of Eustaces yourselves. You're all on your own. Just single-lifers. That's your hard luck."

Slamming a hand on the desk, the Commandant gave his voice a bit more military whoof and demanded,

"Exactly what is a Eustace? Explain to me as clearly as possible."

"I'm in poor position to refuse the information," Leeming conceded with hypocritical reluctance. "Not that it matters much. Even if you gain perfect understanding there is nothing you can do."

"We'll see about that," the Commandant promised. "Tell me all about these Eustaces."

"Every Earthling lives a double-life from birth to death," said Leeming. "He exists in association with an entity which always calls himself Eustace something-or-other. Mine happens to be Eustace Phenackertiban."

"You can see this entity?"

"No, never at any time. You cannot see him, smell him or feel him."

"Then how do you know that this is not a racial delusion?"

"Firstly, because every man can hear his own Eustace. I can hold long conversations with mine, providing that he happens to be within reach, and I can hear him speaking clearly and logically within the depths of my mind."

"You cannot hear him with the ears?"

"No, only with the mind." Leeming took a deep breath and went on. "Secondly, he has the power to do certain things after which there is visible evidence that such things have been done." His attention shifted to the absorbed officer on the left. "For example, if Eustace had a grudge against this officer and advised me of his intention to make

him fall downstairs, and if before long the officer fell downstairs and broke his neck—"

"It could be mere coincidence," the Commandant suggested.

"It could," Leeming agreed, "but there can be far too many coincidences. When a Eustace says he's going to do twenty or fifty things in succession and all of them happen, he's either doing them as promised or he is a most astounding prophet. Eustaces don't claim to be prophets. I don't believe in them either. Nobody, visible or invisible, can read the future with such detailed accuracy."

"That is true enough," admitted the Commandant.

"Do you accept the fact that you have a father and mother?"

"Of course."

"You don't consider it strange or abnormal?"

"Certainly not. It is inconceivable that one should be born without parents."

"Similarly we accept the fact that we have Eustaces and we cannot conceive being without them."

The Commandant thought it over, said to the right-hand officer, "This smacks of mutual parasitism. It would be interesting to learn what benefit they derive from each other."

Leeming chipped in with, "I can't tell you what my Eustace gets out of me. I can't tell you because I don't know."

"You expect me to believe that?" asked the Commandant, making like nobody's fool. He showed his teeth.

"On your own evidence you can talk with him. *Why have you never asked him?*"

"We got tired of asking long, long ago. The subject has been dropped and the situation accepted."

"Why?"

"The answer was always the same. Eustaces readily admit that we are essential to their existence but cannot explain how because there's no way of making us understand."

"That could be a self-preservative evasion," the Commandant offered. "They won't tell you because they don't *want* you to know."

"Well, what do you suggest we do about it?"

Evading that one, the Commandant went on, "What benefit do *you* get out of the association? What good is your Eustace to you?"

"He provides company, comfort, information, advice and—"

"And what?"

Bending forward, hands on knees, Leeming practically spat it at him. "If necessary, vengeance!"

That shook them. The Commandant rocked back. The under-officers registered disciplined apprehension. It's a hell of a war when one can be chopped down by a ghost.

Pulling himself together, the Commandant forced a grim smile into his face. "You're a prisoner. You've been here a good many days. Your Eustace doesn't *seem* to have done much about it."

"That's what you *think*. He's been doing plenty. And he'll do plenty

more, in his own time, in his own way."

"Such as what?"

"Wait and see," Leeming advised, formidably confident.

That did not fill them with delight, either.

"Nobody can imprison more than half a Terran," he went on. "The tangible half. The other half cannot be pinned down by any method whatsoever. It is beyond control. It wanders loose collecting information of military value, indulging a little sabotage, doing just as it pleases. You've created that situation and you're stuck with it."

"Not if we kill you," said the Commandant, in nasty tones.

Leeming gave a hearty laugh. "That would make matters fifty times worse."

"In what way?"

"The life span of a Eustace is longer than that of a Terran. When a man dies his Eustace takes five to ten years to disappear. We have an ancient song to the effect that old Eustaces never die, they only fade away. Our world holds thousands of lonely, disconnected Eustaces gradually fading."

"What of it?"

"Kill me and you'll isolate my Eustace on a hostile world with no man or other Eustace for company. His days are numbered and he knows it. He has nothing to lose, he is no longer restricted by considerations of my safety. He can eliminate me from his plans because I've gone for keeps." He eyed the listeners as he

finished. "He'll run amok, indulging an orgy of destruction. Remember, you're an alien life form to him. He has no feelings and no compunctions with regard to you."

The Commandant reflected in silence. It was difficult to believe all this. But before space-conquest it had been even more difficult to believe things now accepted as commonplace. He could not dismiss it as nonsense. The stupid believe things because they are credulous. The intelligent do not blindly accept but, when aware of their own ignorance, neither do they reject. Right now the Commandant was acutely aware of general ignorance concerning this life form known as Terran.

"All this is not impossible," he said after a while, "but it appears to me somewhat improbable. There are twenty-seven life forms in alliance with us. I do not know of one that exists in natural copartnership with another form."

"The Lathians do," Leeming told him, nonchalantly mentioning the leaders of the foe, the chief source of the opposition.

"You mean they have Eustaces, too?" The Commandant looked startled.

"No. Each Lathian is unconsciously controlled by a thing that calls itself Willy something-or-other. They don't know it and we wouldn't know it except that our Eustaces told us."

"And how did they learn it?"

"As you know, the biggest battles

so far have been fought in the Lathian sector. Both sides have taken prisoners. Our Eustaces told us that each Lathian prisoner had a controlling Willy but was unaware of it." He grinned, added, "And a Eustace doesn't think much of a Willy. Apparently a Willy is a lower form of associated life."

The Commandant frowned, said, "This is something definite, something we should be able to check. But how're we going to do it if Lathian allies themselves are ignorant of the real state of affairs?"

"Easy as pie," Leeming offered. "They're holding a bunch of Terran prisoners. Get someone to ask those prisoners whether the Lathians have got the Willies."

"We'll do just that," approved the Commandant, in the manner of one about to call a bluff. He turned to the right-hand officer. "Bamashim, go beam a signal to our chief liaison officer at Lathian H.Q., and get him to question those prisoners."

"You can check further still," Leeming interjected, "just to make doubly sure. To us, anyone who shares his life with an invisible being is known as a Nut. Ask the prisoners whether the Lathians are all Nuts."

"Take note of that and have it asked as well," the Commandant ordered the officer. He returned attention to Leeming. "Since you could not anticipate your forced landing and capture, and since you've been closely confined, there is no possi-

bility of collusion between you and Terran prisoners far away.”

“That’s right,” Leeming agreed.

“Therefore I shall weigh your evidence in the light of what replies come to my signal.” He stared hard at the other. “If those replies fail to confirm your statements, I will know that you are a liar in some respects and probably a liar in all respects. Here, we have special and very effective methods of dealing with liars.”

“That’s to be expected. But if the replies do confirm me, you’ll know I’ve told the truth, won’t you?”

“No,” snapped the Commandant.

It was Leeming’s turn to be shocked. “Why not?”

Thinning his lips, the Commandant said, “Because I know full well that there cannot have been direct communication between you and the other Terran prisoners. However, that means nothing. There may have

been collusion between your Eustace and their Eustaces.”

Then he bent sidewise, jerked open a drawer, placed a loop assembly on the desk. Then another and another. A bunch of them.

“Well,” he invited, “what have you to say to that?”

Leeming beat his brains around fast. He could see what the other meant. He could talk to his Eustace. His Eustace could talk to other Eustaces. The other Eustaces could talk to their imprisoned partners.

Get yourself out of that!

They were waiting for him, watching his face, counting the seconds needed to produce an answer. The longer he took to find one the weaker it would be. The quicker he came up with something good the more plausible its effect.

He was inwardly frantic by the



time he saw an opening and grabbed at it.

"You're wrong on two counts."

"State them."

"Firstly, one Eustace cannot communicate unaided with another over a distance so enormous. His mind won't reach that far. To do it he has to use a Terran who, in his turn, must have radio equipment available."

"We've only your word for it," the Commandant pointed out. "If a Eustace can communicate without limit, it would be your policy to try to conceal the fact."

"I can do no more than give you my word regardless of whether or not you credit it."

"I do not credit it—yet. Proceed to your second count. It had better be convincing."

"It is," Leeming assured. "On this one we don't have my word for it. We have yours."

"Nonsense!" exclaimed the Commandant. "I have made no statements concerning Eustaces."

"On the contrary, you have said that there could be collusion between them."

"What of it?"

"There can be collusion only if Eustaces genuinely exist, in which case my evidence is true. But if my evidence is false, then Eustaces do not exist and there cannot possibly be a conspiracy between nonexistent things."

The Commandant sat perfectly still while his face took on a faint shade of purple. He looked and felt

like the trapper trapped. Left-hand officer wore the expression of one struggling hard to suppress a disrespectful snicker.

"If," continued Leeming, piling it on for good measure, "you don't believe in Eustaces then you cannot logically believe in conspiracy between them. Contrariwise, if you believe in the possibility of collusion then you've got to believe in Eustaces. That is, of course, if you're in bright green britches and your right mind."

"Guard!" roared the Commandant. He pointed an angry finger. "Take him back to the cell." They were hustling the prisoner through the door when he changed tactics and bawled, "Halt!" He snatched up a loop assembly, gesticulated with it at Leeming. "Where did you get the material to manufacture this?"

"Eustace brought it for me. Who else?"

"Get out of my sight!"

"*Merse, faplap!*" urged the guards, prodding with their guns. "*Amash! Amash!*"

He spent the rest of that day and all the next one sitting or lying on the bench reviewing what had happened, planning his next moves and, in lighter moments, admiring his own ability as a whacking great liar.

Now and again he wondered how his efforts to dig himself free with his tongue compared with Rigellian attempts to do it with bare hands. Who was making the most progress

and—of the greatest importance—who, once out, would stay out? One thing was certain: his method was less tiring to the body though more exhausting to the nerves.

Another advantage was that for the time being he had sidetracked their intention of squeezing him for military information. Or had he? Possibly from their viewpoint his revelations concerning the dual nature of Terrans were infinitely more important than details of armaments, which data might be false anyway. Nevertheless he had dodged what otherwise might have been a rough and painful interrogation.

Next time the spyhole opened he got down on his knees and said in very loud tones, "Thank you, Eustace! Oh, thank you!" and left the jumpy Marsin to wonder who had arrived at the crossroads in time for some of Eustace's dirty work.

Near midnight, just before sleep came on, it occurred to him that there was no point in doing things by halves. Why rest content to smile knowingly whenever the enemy suffered a petty misfortune?

He could extend it farther than that. No form of life was secure from the vagaries of chance. Good fortune came along as well as bad. There was no reason why Eustace should not get credit for both, no reason why he, Leeming, should not take to himself the implied power to reward as well as to punish.

That wasn't the limit, either. Bad luck and good luck are positive phases. He could cross the neutral

zone and confiscate the negative phases. Through Eustace he could assign to himself not only the credit for things done, good or bad, but also for things *not* done. He could exploit not only the things that happened but also those that did not happen.

The itch to make a start right now was irresistible. Rolling off the bench, he belted the door from top to bottom. The guard had just been changed, for the eye that peered in was that of Kolum, a character who had bestowed a kick in the ribs not so long ago. Kolum was a cut above Marsin, being able to count upon all twelve fingers if given time to concentrate.

"So it's you," said Leeming, showing vast relief. "I begged him to lay off you, to leave you alone at least a little while. He is impetuous and much too drastic. I can see you are more intelligent than the others and, therefore, able to change for the better. Nobody with brains is beyond hope."

"Huh?" said Kolum, half scared, half flattered.

"So he's left you alone," Leeming pointed out. "He's done nothing to you—yet." He increased the gratification. "I do hope I can continue to control him. Only the stupidly brutal deserve slow death."

"That is true," agreed Kolum, eagerly. "But what—?"

"Now," continued Leeming with firmness, "it is up to you to prove that my confidence is justified. All

I want you to do is give a message to the Commandant."

"I dare not disturb him at this hour. It is impossible. The sergeant of the guard will not permit it. He will—"

"It is to be given to him personally when he awakes first thing in the morning."

"That is different," said Kolum, sweating slightly. "But if the Commandant disapproves of the message he will punish you and not me."

"Write," ordered Leeming.

Kolum leaned his gun against the opposite wall, dug pencil and paper out of a pocket.

"To the Most Exalted Lousy Screw," began Leeming.

"What does 'lousy screw' mean?" asked Kolum, struggling with the two Terran words.

"It's a title. It means 'your highness.' Boy, how high he is!" Leeming pinched his nose while the other pored over the paper. He continued to dictate. "The food is very poor and insufficient. I have lost much weight and my ribs are beginning to show. My Eustace does not like it. I cannot be held responsible for his actions. Therefore I beg Your Most Exalted Lousy Screwship to give serious consideration to this matter."

"There are many words," complained Kolum, martyred, "and I shall have to rewrite them more readably when I go off duty."

"I know. And I appreciate the trouble you're taking on my behalf." Leeming gave him a look of fra-

ternal fondness. "That's why I feel sure that you'll live long enough to do it."

"I must live longer than that," insisted Kolum, bugging his eyes. "I have the right to live, haven't I?"

"That's exactly my own argument," said Leeming, in the manner of one who has striven all night to establish the irrefutable but cannot yet guarantee success.

He returned to the bench. The light went off, the spyhole shut. Four stars peeped through the window slot—and they were not unattainable.

In the morning breakfast came half an hour late but consisted of one full bowl of lukewarm pap, two thick slices of brown bread heavily smeared with grease, and a large cup of stuff vaguely resembling paralyzed coffee. He ate the lot with mounting triumph.

No interview that day or the next. No summons for a week. Evidently His Lousy Screwship was still awaiting a reply from the Lathian sector and didn't feel inclined to make another move before he got it. However, meals remained more substantial, a fact that Leeming viewed as positive evidence that someone was insuring himself against disaster.

Then one morning the Rigellians acted up. From the cell they could be heard but not seen. Every day at an hour after dawn the tramp of their two thousand pairs of feet sounded somewhere out of sight and

died away toward the workshops.

This morning they came out singing, their voices holding a touch of defiance. Something about Asta Zangasta's a dirty old man, got fleas on his chest and sores on his pan. Guards yelled at them. Singing rose higher, the defiance increased. Leeming got below the window, listened intently, wondered who the blazes was this much-abused Asta Zangasta. Probably the local life form's largest cheese, the big boss of this world.

The bawling of two thousand voices rose crescendo. Guards shouted frenziedly and were drowned out. A warning shot was fired. Guards in the watchtowers edged their guns around.

Next came the sound of blows, shots, scuffling sounds, yells of fury. A bunch of twenty guards raced flat-footed past Leeming's window, heading for the fracas. The uproar continued for twenty minutes, died away. Resulting silence could almost be felt.

Exercise time, Leeming had the yard to himself. Not a soul there. He mooched around gloomily, found Marsin on yard patrol.

"What's happened?"

"They misbehaved. They are being kept in the workshops to make up loss of production. It is their own fault. They started work late to slow down output. We didn't even have time to count them."

Leeming grinned in his face. "And some guards were hurt. Not severely. Just enough to give them

a taste of what's to come. Think it over."

"Eh?"

"But *you* were not hurt. Think that over, too!"

He ambled off, leaving Marsin bewildered. Then a thought struck him. "*We had not time even to count them.*" He returned, said, "Tomorrow some of you will wish you'd never been born."

"You are threatening us?"

"No—I'm making a promise. Tell your officer. Tell the Commandant. It will help you escape the consequences."

"I will tell them," said Marsin, relieved and grateful.

His guess was dead on the beam. The Rigellians were too shrewd to invite thick ears and black eyes without good reason. It took the foe a full day to arrive at the same conclusion.

One hour after dawn the Rigellians were marched out dormitory by dormitory, in batches of fifty instead of the usual steady stream. They were counted in fifties, the easy way. This simple arithmetic got thrown out of kilter when one dormitory gave up only twelve prisoners, all of them sick, weak, wounded or otherwise handicapped.

Infuriated guards rushed indoors to drag out the nonattending thirty-eight. They weren't there. The door was firm and solid, the window bars intact. It took considerable galumphing around to detect a hollow spot in the floor, and under that a deep

shaft from which ran a tunnel. The said tunnel was empty.

Sirens wailed, guards pounded all over the shop, officers shouted, the entire place began to resemble a madhouse. The Rigellians got it good and hard for spoiling the previous morning's count and thus giving the escapees an extra day's lead. Boots and gun butts were freely used, bodies dragged aside unconscious.

The surviving top-ranker of the offending dormitory, a lieutenant with a bad limp, was put against a wall and shot. Leeming could see nothing but heard the hoarse commands of, "Present . . . aim . . . fire!" and the following volley.

He prowled round and round his cell, clenching and unclenching his fists, swearing mightily to himself. The spyhole opened but hastily shut before he could spit right in somebody's eye.

The upset continued as inflamed guards searched all dormitories one by one, tested doors, bars, floors and walls. Officers screamed threats at groups of Rigellians who were slow to respond to orders.

At twilight outside forces brought in seven tired, bedraggled escapees caught on the run. "Present . . . aim . . . fire!" Leeming battered his door but the spyhole remained shut and none answered. Two hours later he'd made another coiled loop with the last of his wire. He spent half the night talking into it, menacingly, at the top of his voice. Nobody took the slightest notice.

A feeling of deep frustration had

come over him by noon next day. He estimated that the Rigellian escape must have taken at least a year to prepare. Result: eight dead, thirty-one still loose but planet-bound and probably fated to ultimate recapture, most of two thousand getting it rough in consequence, his own efforts balled up. He did not resent the break, not one little bit. Good luck to them. But if only it had occurred a couple of months earlier or later.

Immediately after dinner four guards came for him. "The Commandant wants you at once." Their manner was surly, somewhat on edge. One wore a narrow bandage around his scaly pate, another had a badly swollen eye.

Just about the worst moment to choose, thought Leeming, gloomily. The Commandant would be in the mood to go up like a rocket. You cannot reason with a person who is in a purple rage. Emotion comes uppermost, words are disregarded, arguments are dismissed. He was going to have a tough job on his hands.

As before, the Commandant sat behind his desk but there were no accompanying officers. At his side posed an elderly civilian. The latter studied the prisoner curiously as he entered and took a seat.

"This is Pallam," introduced the Commandant, displaying unexpected amiability that dumfounded the hearer. "He has been sent along by no less a person than Zangasta himself."

"A mental specialist?" guessed Leeming, frowning at the oldster.

"Nothing like that," assured Pallam quietly. "I am particularly interested in all aspects of symbiosis."

Leeming's back hairs stirred. He didn't like the idea of being cross-examined by an expert. They had unmilitary minds and a pernicious habit of digging up contradictions in a story.

"Pallam wishes to ask you a few questions," informed the Commandant. "But those will come later." He leaned back, put on a self-satisfied expression. "For a start, let me say that I am indebted to you for the information you gave me last time you were here."

"You mean it has proved useful to you?" inquired Leeming, hardly believing his ears.

"Very much so. The guards responsible for Dormitory Fourteen are to be drafted to the battle areas where they will be stationed at space-ports liable to attack. That is their punishment for gross neglect of duty." He gazed thoughtfully at the other, went on, "The big escape would have made that my fate also had not Zangasta considered it a minor matter when compared with what I have discovered through you."

"But when I asked, you saw to it that I had better food. Surely you expected some reward?"

"Eh?" The Commandant registered surprise followed by slow understanding. "I did not think of that."

"So much the better," said Leeming, with hearty approval. "A good deed is doubly good when done with no ulterior motive. Eustace will take note of that."

"You mean," put in Pallam, "that his code of ethics is identical with your own?"

Why did that fellow have to put his spoke in? Be careful now!

"Similar in some respects but not identical."

"What is the most outstanding difference?"

"Well," said Leeming, playing for time, "it's hard to decide." He rubbed his brow while his mind whizzed dizzily. "I'd say in the matter of vengeance."

"Define the difference," invited Pallam, sniffing along the trail like a bloodhound.

"From my viewpoint," said Leeming, carefully, "he is unnecessarily sadistic."

There, that gave the needed coverage for any widespread claims it might be desirable to make later.

"In what way?" Pallam persisted.

"My instinct is to take prompt action, get things over and done with. His tendency is to prolong the agony."

"Explain further," pressed Pallam, making a thorough nuisance of himself.

"If you and I were deadly enemies, and I had a gun, I would shoot you and kill you. But if Eustace had you marked for death he'd make it slower, more gradual."

"Describe his method."

"First, he'd make you know that you were marked. Then he'd do nothing until at last you got the notion that nothing ever would be done. Then he'd remind you with a minor blow. When resulting alarm had worn off he'd strike a harder one. And so on and so on, with increasing intensity spread if necessary over months and years. That would continue until your doom became plain and too much to bear any longer." He thought again, added, "No Eustace has ever killed anyone. If anyone dies because of him, it is by his own hand."

"He drives a victim to suicide?"

"Yes."

"And there is no way of avoiding such a fate?"

"Yes there is," Leeming contradicted. "At any time the victim can gain freedom from fear by redressing the wrong he has done to that Eustace's partner."

"Such redress immediately terminates the vendetta?" pursued Pallam.

"That's right."

"Whether or not you approve personally?"

"Yes. If my grievance ceases to be real and becomes only imaginary, my Eustace refuses to recognize it or do anything about it."

"So what it boils down to," said Pallam, pointedly, "is that his method provides motive and opportunity for repentance while yours does not?"

"I suppose so."

"Which means that he has a more balanced sense of justice?"

"He can be darned ruthless," said Leeming, momentarily unable to think of anything less feeble.

"That is beside the point." Pallam lapsed into meditative silence, then remarked to the Commandant, "It seems that the association is not between equals. The invisible component is also the superior one."

Cunning old hog, Leeming thought to himself. But if he was trying to tempt the prisoner into a heated denial he was going to be disappointed.

So he sat and said nothing but carefully wore the look of one whose status has been accurately weighed in the balance and found wanting. Come to that, there's no shame in being defined as inferior to one's own mind.

Pallam took on an expression of sharpness as he continued, "I assume that when your Eustace takes upon himself the responsibility for wreaking vengeance he does so because circumstances prevent punishment being administered either by yourself or the community?"

"That's pretty well correct," admitted Leeming, warily.

"In other words, he functions only when both you and the law are impotent?"

"He takes over when need arises," informed Leeming, striving to give the point some ambiguity.

"That is substantially what I said," declared Pallam, a little coldly. He bent forward, watched the

other keen-eyed and managed to make his attitude intimidating. "Now let us suppose your Eustace finds excellent reason to punish another Terran. *What does the victim's Eustace do about it?*"

Leeming's mouth opened and the words, "Not much," popped out of their own accord. For a mad moment he felt that Eustace had actually arrived and joined the party.

"Why not?"

"I have told you before and I am telling you again that no Eustace will concern himself for one moment with an imaginary grievance. A guilty Terran has no genuine cause for complaint. He brought vengeance on himself and the cure lies in his own hands. If he doesn't enjoy suffering, he need only get busy and undo whatever wrong he has done."

"Will his Eustace urge him or influence him to take action necessary to avoid punishment?"

"Never having been a victim myself," said Leeming, fairly oozing virtue, "I am unable to tell you. I suppose it would be near the truth to say that Terrans behave because association with Eustaces makes them behave. They've little choice about the matter."

"All that is acceptable," conceded Pallam, "because it is consistent—as far as it goes."

"What d'you mean?"

"Let's take it to the bitter end. I do not see any rational reason why any victim's Eustace should allow

his partner to be driven to suicide. It is contrary to the basic law of survival."

"Nobody commits suicide until after he's gone off his rocker."

"What of it?"

"An insane person is of no avail to any Eustace. To a Eustace, he's already dead, no longer worth defending or protecting. Eustaces associate only with the sane."

Pouncing on that, Pallam exclaimed, "So the benefit they derive is rooted somewhere in Terran minds, it is a mental sustenance?"

"I don't know."

"Does your Eustace ever make you feel tired, exhausted, perhaps a little stupified?"

"Yes," said Leeming. And how, brother! Right now he could choke Eustace to death.

"I would much like to continue this for months," Pallam observed to the Commandant. "It is an absorbing subject. There are no records of symbiotic association in anything higher than plants and six species of the lower *elames*. To find it among sentient forms, and one of them intangible, is remarkable, truly remarkable!"

The Commandant looked awed.

"Give him your report," urged Pallam.

"Our liaison officer, Colonel Sho-muth, has replied from the Lathian sector," the Commandant told Leeming. "He is fluent in Cosmoglotta and, therefore, was able to question many Terran prisoners. We sent him

a little more information and the result is significant."

"What else did you expect?" asked Leeming.

Ignoring that, the Commandant went on, "He said that most of the prisoners refused to make comment or admit anything. That is understandable. Nothing could shake their belief that they were being tempted to surrender information of military value. So they remained silent." He glanced at his listener. "But some talked."

"There are always a few willing to blab," remarked Leeming, looking resigned.

"Certain officers talked, including Cruiser Captain Tompass... Tompus—"

"Thomas?"

"Yes, that's the word." Turning round in his chair the Commandant pressed a wall switch. "This is the beamed interview, unscrambled and recorded on tape."

A crackling hiss poured out of a perforated grid in the wall. It grew louder, died down to a background wash. Voices came out of the grid.

Shomuth: "Captain Thomas, I have been ordered to check certain information already in our possession. You have nothing to lose by giving answers, nothing to gain by refusing them. There are no Lathians present, only the two of us. You may speak freely and what you say will be treated in confidence."

Thomas: "What d'you want to know?"

Shomuth: "Whether our Lathian allies really are Nuts."

Thomas, after a pause: "You want the blunt truth?"

Shomuth: "We do."

Thomas: "All right, they are nuts."

Shomuth: "And they have the Willies?"

Thomas: "Where did you dig up this information?"

Shomuth: "That's our business. Please answer the question."

Thomas, belligerently: "Not only have they got the willies but they'll have a darned sight more of them before we're through."

Shomuth, puzzled: "How can that be? We have learned that each Lathian is unconsciously controlled by a Willy. Therefore the total number of Willies is limited. It cannot be increased except by birth of more Lathians."

Thomas, quickly: "You got me wrong. What I meant was that as Lathian casualties mount up the number of loose Willies will increase. There will be lots more of them in proportion to the number of Lathian survivors."

Shomuth: "Yes, I see what you mean. And it will create a psychic problem." Pause. "Now, Captain Thomas, have you any reason to suppose that many unattached Willies might be able to seize control of another and different life form? Such as my own species, for example?"

Thomas, with enough menace to



deserve a space medal: "I wouldn't be surprised."

Shomuth: "You don't know for sure?"

Thomas: "No."

Shomuth: "It is true, is it not, that you are aware of the real Lathian nature only because you have been informed of it by your Eustace?"

Thomas, startled: "My *what?*"

Shomuth: "Your *Eustace*. Why should that surprise you?"

Thomas, recovering swiftly enough to earn a bar to the medal: "I thought you said Useless. Ha-ha! Silly of me. Yes, my Eustace, You're dead right there."

Shomuth, in lower tones: "There are four hundred twenty Terran prisoners here. That means four

hundred twenty Eustaces wandering loose on this planet. Correct?"

Thomas: "I am unable to deny it."

Shomuth: "The Lathian heavy cruiser *Veder* crashed on landing and was a total loss. The Lathians attributed it to an error of judgment on the part of the crew. But that was just three days after you prisoners were brought here. Was it a mere coincidence?"

Thomas, oh, good, but good: "Work it out for yourself."

Shomuth: "All right. Here's something else. The biggest fuel dump in this part of the galaxy is located sixty miles south of here. A week ago it blew up to total destruction. The loss was very severe and will handicap our allied fleets for some time to come. Technicians

theorize that a static spark caused one tank to explode and that set off the rest. We can always trust technicians to come up with a plausible explanation."

Thomas: "Well, what's wrong with it?"

Shomuth: "That dump has been there more than four years. There's been no static sparks during that time."

Thomas: "What are you getting at?"

Shomuth, pointedly: "You have admitted yourself that there are four hundred and twenty Eustaces free to do as they like."

Thomas, in tones of stern patriotism: "I am admitting nothing. I refuse to answer any more questions."

Shomuth: "Has your Eustace prompted you to say that?"

Silence.

Reversing the switch, the Commandant said, "There you are. Eight other Terran officers gave more or less the same evidence. Zangasta himself has listened to the records and is deeply concerned about the situation."

"Tell him he needn't bother nursing his pate," Leeming airily suggested. "It's all a lot of bunk, a put-up job. There was collusion between my Eustace and theirs."

Turning a faint purple, the Commandant retorted, "As you emphasized at our last meeting, there cannot be collusion without Eus-

taces. So it makes no difference either way."

"I'm glad you can see it at last."

"Let it pass," chipped in Pallam, impatiently. "It is of no consequence. The confirmatory evidence is adequate no matter how we look at it."

Thus prompted, the Commandant continued, "I have been doing some investigating myself. Eight of my guards earned your enmity by assaulting you. Of these, four are now in hospital badly injured, two more are to be drafted to the fighting front."

"The other two," said Leeming, "gained forgiveness. Nothing has happened to them."

"No. Nothing has happened."

"I cannot give the same guarantee with respect to the firing squad, the officer in charge of it, or the higher-up who issued the order that helpless prisoners be shot. It all depends on how my Eustace feels about it."

"Why should he care?" put in Pallam. "They were only Rigelians."

"They were allies. And allies are friends. I feel bad about the needless slaughtering of them. Eustace is sensitive to my emotions."

"But not necessarily obedient to them?"

"No."

"In fact," pressed Pallam, "if there is any question of one serving the other, it is *you* who obeys *him*?"

"Most times, anyway."

"Well, it confirms what you've already told us." He ventured a thin

smile. "The chief difference between Terrans and Lathians is that you know you're controlled whereas the Lathians are ignorant of it."

"We are not controlled consciously or unconsciously," Leeming insisted. "We exist in mutual partnership, same as you do with your wife. It's mastery by neither party."

"I wouldn't know, never having been mated," said Pallam. He transferred his attention to one side. "Carry on, Commandant."

"You may as well be told that this has been set aside as a penal planet," informed the Commandant. "We are already holding a large number of prisoners, mostly Rigellians."

"What of it?" Leeming prompted.

"There are more to come. Two thousand Centaurians and six hundred Thetans are due to arrive and fill a new jail next week. Our allied forces will transfer more Federation life forms as soon as ships are available." He eyed the other speculatively. "It's only a matter of time before they start dumping Terrans upon us as well."

"Is it bothering you?"

"Zangasta has decided not to accept Terrans."

"That's up to him," said Leeming, blandly indifferent.

"Zangasta has a clever mind," the Commandant opined. "He is of the firm opinion that to assemble a formidable army of prisoners all on one planet, and then put some thousands of Terrans among them, is to create a potentially dangerous situation. He foresees trouble on a

vaster scale than we could handle. Indeed, we might lose this world, strategically placed in the rear, and become subject to the violent attacks of our own allies."

"That's the angle he puts out for publication. He's got a private one too."

"Eh?"

Looking grim, Leeming continued, "Zangasta himself first gave orders that escaped prisoners were to be shot immediately after recapture. He must have done, otherwise nobody would dare shoot them. Now he's jumpy because of one Eustace. He thinks a few thousand Eustaces will be a greater menace to him. But he's wrong."

"Why is he wrong?" inquired the Commandant.

"Because it isn't only the repentant who have no cause to fear. The dead haven't either. He'd better countermand that order if he wants to keep on living."

"I shall inform him of your remarks. However, such cancellation of orders may not be necessary. As I have told you, he is clever. He has devised a subtle strategy that will put all your evidence to the final, conclusive test and at the same time may solve his problems."

Feeling vague alarm, Leeming asked, "Am I permitted to know what he intends to do?"

"He has given instructions that you be told. And he has started doing it." The Commandant waited for the sake of extra effect. "He has

beamed the Federation a proposal to exchange prisoners."

Leeming fidgeted around in his seat. Holy smoke, the plot was thickening with a vengeance. His sole purpose from the beginning had been to talk himself out of jail and into some other situation from which he could scoot at top speed. Now they were taking up his story and plastering it all over the galaxy. Oh, what a tangled web we weave when first we practice to deceive.

"What's more," the Commandant went on, "the Federation has accepted providing only that we exchange rank for rank. That is to say, captains for captains, navigators for navigators and so forth."

"That's reasonable."

"Zangasta," said the Commandant, grinning like a wolf, "has agreed in his turn—providing that the Federation accepts all Terran prisoners first and makes exchange on a basis of two for one. He is now awaiting their reply."

"Two for one?" echoed Leeming. "You want them to surrender two prisoners for one Terran?"

"No, of course not." Leaning forward, he increased the grin and showed the roots of his teeth. "Two of ours for one Terran and his Eustace. That's fair enough, isn't it?"

"It's not for me to say. The Federation is the judge." Leeming swallowed hard.

"Until a reply arrives and the matter is settled, Zangasta wishes you to have better treatment. You will be transferred to the officers'

quarters outside the walls and you will share their meals. Temporarily you'll be treated as a noncombatant and you'll be very comfortable. It is necessary that you give me your parole not to escape."

Ye gods, that was another stinker. The entire fiction was shaped toward ultimate escape. He couldn't abandon it now. Neither was he willing to give his word of honor with the cynical intention of breaking it.

"Parole refused," he said, firmly.

The Commandant registered incredulity. "You are not serious?"

"I am. I've no choice. Terran military law doesn't allow a prisoner to give such a promise."

"Why not?"

"Because no Terran can accept responsibility for his Eustace. How can we swear not to get out when all the time we're already half out?"

"Guard!" called the Commandant, visibly disappointed.

He mooched uneasily around the cell for a full week, occasionally chatting with Eustace night-times for the benefit of ears outside the door. The food remained better. The guards treated him with diffidence. Four more recaptured Rigelians were brought back but not shot. All the signs and portents were that he'd still got a grip on the foe.

Nevertheless, he was badly bothered. The Federation in general and Earth in particular knew nothing whatsoever about Eustaces and therefore were likely to view a two-for-one proposition with the contempt

it deserved. A blank refusal on their part might cause him to be plied with awkward questions impossible to answer.

Sooner or later it would occur to them that they were afflicted with the biggest liar in cosmic history. They'd then devise tests of fiendish ingenuity. When he flunked them, the balloon would go up.

He wasn't inclined to give himself overmuch credit for kidding them along so far. The books he'd been reading had shown that the local religion was based upon reverence for ancestral spirits. They were also familiar with what is known as poltergeist phenomena. The ground had been prepared for him in advance. He'd merely ploughed it and sown the crop. When a victim believes in two kinds of invisible beings it isn't too hard to make him swallow a third.

But when the Federation beamed a curt invitation to go jump, it was possible that the third type would be regurgitated with violence. Unless by fast talk he could cram it back down their gullets when it was already halfway out. How to do that?

He was still stewing it over and over when they came for him again. The Commandant was there but Pal-lam was not. Instead, a dozen civilians eyed him curiously. That made a total of thirteen, a very suitable number to pronounce him ready for the chopper.

Feeling as much the center of attention as a six-tailed wombat at the

zoo, he sat down and four civilians started chivvying him at once, taking it in relays. They were interested in only one subject, namely, bopamagilvies. It seemed they'd been playing with them for hours and achieved nothing except some practice at acting daft.

On what principle did they work? Did they focus mental output into a narrow beam? At what distance did his Eustace get beyond straight conversation and need to be called with a loop? Why was it necessary to make directional search before getting a reply? How did he know how to make a loop in the first place?

"I can't explain. How does a bird know how to make a nest? The knowledge seems instinctive. I've known how to call Eustace ever since I was old enough to shape a piece of wire."

"Will any kind of wire do?"

"So long as it's nonferrous."

"Are all Terran loops of exactly the same construction and dimensions?"

"No. They vary with the individual.

Somehow he beat them off, feeling hot in the forehead and cold in the belly. Then the Commandant took over.

"The Federation has refused to accept Terran prisoners ahead of other species, or to exchange them two for one, or to discuss the matter any further. They accuse Zangasta of bad faith. What have you to say to that?"

Steeling himself, Leeming commented, "On your side there are twenty-seven life forms of which the Lathians and the Zebbs are by far the most powerful. Now if the Federation wanted to give priority of exchange to one species, do you think the others would agree? If the favored species happened to be the Tansites, would the Lathians and Zebbs vote for them to head the line-up?"

A civilian chipped in, a tall, authoritative specimen. "I am Daverd, personal aide to Zangasta. He is of your own opinion. He believes the Terrans have been outvoted. Therefore I am commanded to ask you one question."

"What is it?"

"Do your Federation allies know about your Eustaces?"

"No."

"You have succeeded in hiding the facts from them?"

"There's no question of hiding facts. With friends the facts just don't become apparent. Eustaces take action only against enemies and that's something that can't be concealed."

"Very well. Daverd came closer while the others looked on. "The Lathians started this war and the Zebbs went with them by reason of military alliance. The rest of us got dragged in for one cause or another. The Lathians are powerful. But, as we now know, they're not responsible for their actions."

"What's this to me?"

"Separately, we numerically weak-

er life forms cannot stand against the Lathians or the Zebbs. But together we are strong enough to step out of the war and maintain our right to remain neutral. So Zangasta has consulted the others."

Jumping jiminy, what you can do with a few feet of copper wire!

"He has received their replies today," Daverd continued. "They are willing to make a common front and get out of the war providing that the Federation is equally willing to exchange prisoners and recognize neutrality."

"Such sudden unanimity among minors tells me something pretty good," observed Leeming, displaying satisfaction.

"It tells you what?"

"Federation forces have won a major battle lately. Somebody's been scalped."

Daverd refused to confirm or deny it. "At the moment you're the only Terran we hold on this planet. Zangasta thinks you could well be spared."

"Meaning what?"

"He has decided to send you to the Federation. It is your job to persuade them to agree to our plans. If you fail—a couple of hundred thousand hostages may suffer."

"For which the Federation may retaliate."

"They won't know. There'll be no Terrans or Eustaces here to inform them by any underhanded method. We're keeping Terrans out.

The Federation cannot use knowledge it doesn't possess."

"No," agreed Leeming. "It's impossible to use what you haven't got."

They provided a light destroyer crewed by ten Zangastans and that took him to a servicing planet right on the fringe of the battle area. It was a Lathian outpost but those worthies showed no interest in what their smaller allies were up to. They got to work relining the destroyer's tubes while Leeming was transferred to a one-man Lathian scoutship. The ten Zangastans officiously saluted before they left him.

From that point he was strictly on his own. Take-off was a hells. The seat was awkwardly shaped and too big, the controls in the wrong places and too far apart. The little ship was fast and powerful but responded differently from his own. How he got up he never knew, but he made it.

After that, there was the constant risk of being tracked by Federation detecting devices and blown apart in full flight.

He arrowed straight for Terra. His sleeps were uneasy and restless. The tubes were not to be trusted despite that flight-duration would be only one-third of that done in his own vessel. The strange autopilot was not to be trusted merely because it was of alien design. The ship itself wasn't to be trusted for the same reason. The forces of his own side were not to be trusted because they'd

tend to shoot first and ask questions afterward.

In due time he came in fast on Terra's night side and plonked it down in a field a couple of miles west of the main spaceport.

The moon was shining bright along the Wabash when he approached the front gate afoot and a sentry yelled, "Halt! Who goes there?"

"Lieutenant Leeming and Eustace Phenackertiban."

"Advance and be recognized."

He walked forward, thinking to himself that such an order was somewhat dunderheaded. Be recognized. The sentry had never seen him in his life and wouldn't know him from Myrtle McTurtle.

At the gate a powerful cone of light shot down upon him. Somebody with three chevrons on his sleeve emerged from a nearby hut bearing a scanner on the end of a black cable. The scanner got waved over the arrival from head to feet, concentrating mostly upon the face.

A loud-speaker in the hut said, "Bring him in to Intelligence H.Q."

They started walking.

The sentry let go an agitated yelp of, "Hey, where's the other guy?"

"What guy?" asked the escorting sergeant, looking around.

"He's nuts," Leeming confided.

"You gave me *two* names," asserted the sentry, slightly bellicose.

"Well, if you ask the sergeant nicely he'll give you two more," said Leeming. "Won't you, sarge?"

"Let's get going," suggested the sergeant, showing impatience.

They reached Intelligence H.Q. The duty officer was Colonel Farmer, a florid character Leeming had met many times before. Farmer gazed at him incredulously and said, "Well!" He said it seven times.

Without preamble, Leeming growled, "What's all this about us refusing to make a two-for-one swap for Terran prisoners?"

Farmer started visibly. "You know about it?"

"How could I ask if I didn't?"

"All right. Why should we accept such a cockeyed proposition?"

Bending over the desk, hands splayed upon it, Leeming said, "All we need do is agree—upon one condition."

"What condition?"

"That they make a similar agreement with respect to Lathians. Two Federation prisoners for one Lathian and one Willy."

"One *what*?"

"One Willy. The Lathians will take it like birds. They've been propagandizing all over the shop that one Lathian is worth two of anything else. They're too conceited to refuse such an offer. They'll advertise it as proof that even an enemy knows how good they are."

"But—" began Farmer, a little dazed.

"Their allies will agree also, but from different motives that don't

matter to us anyway. Try it for size. Two Federation prisoners for one Lathian and his Willy."

Farmer protruded his belly and roared, "What the blue blazes is a Willy?"

"You can easily find out," assured Leeming. "Consult your Eustace."

Showing alarm, Farmer lowered his tones to a soothing pitch and said as gently as possible, "You were reported missing and believed killed."

"I crash-landed and got taken prisoner in the back of beyond. They slung me in the jug."

"Yes, yes," said Colonel Farmer, making pacifying gestures. "But how on earth did you get away?"

"Farmer, I cannot tell a lie. I hexed them with my bopamagilvie."

"Huh?"

"So I left by rail," informed Leeming, "and there were ten fap-laps carrying it."

Catching the other unaware he let go a vicious kick at the desk and made a spurt of ink leap across the blotter.

"Now let's see some of the intelligence they're supposed to have in Intelligence. Beam the offer. Two for a Lathian and a Willy Terwilliger." He stared wildly around. "And find me a bed. I'm dead beat."

Holding himself in enormous restraint, Farmer said, "Lieutenant, do you realize that you are talking to a colonel?"

Leeming used the word.

THE END



ARTISTIC DETAIL

Illustrated by Sam Andre

That chesty alien on the cover this time gave Kelly Freas troubles; how do you design a gunstock for a creature with an oil-drum chest? And when you have designed it... what will light and shadow detail do on such a contraption?

Of course it would be possible to set up the thing as a pure mental image, rotate it, light it, and study the detail in imagination—but sometimes it's less total effort to build a model of the darned thing.

The stock is balsa; the twin barrel affairs are pencil leads (heavy gauge, for drawing pencils).

And this is one time Kelly Freas, illustrator, has his work illustrated by someone else; Sam Andre is editor of the Street & Smith Sports books, and a long-time news photographer.



THE PEASANT GIRL

If the other fellow's talent is obvious, overwhelming, enough, you'll finally recognize it. But about then you're apt to fail to notice your own great talents.

BY PAUL JANVIER

Because one of its two people had stopped living there during the night, the house was smaller the following morning. So it was a cottage door that Henry Spar closed behind him, just an hour past dawn.

He looked at the low roof and the clapboarding which no rain had ever touched, and which was nevertheless just weatherworn enough. The cottage looked snug—comfortable to live in.

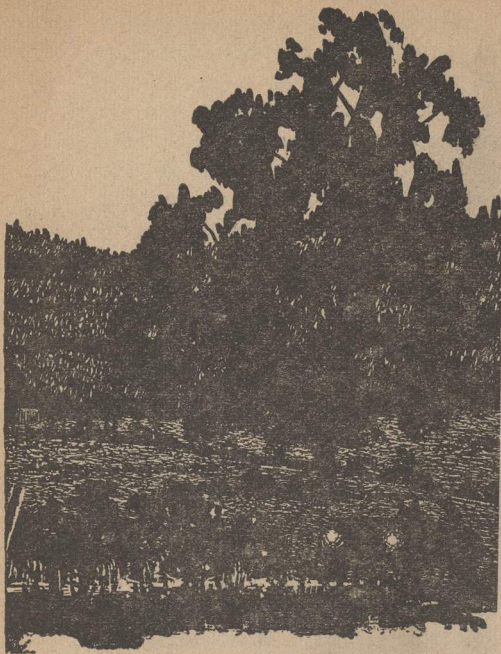

Illustrated by van Dongen

Henry's thin-set lips moved with quick pain. "Might of waited a decent time," he grunted at the sky.

The windowshades pulled themselves shut. Henry picked up the scuffed suitcase between his feet and walked away, his head down.

He stood patiently waiting for the bus to come. His long, boney face held no expression, and neither did his eyes. His thin, graying hair was plastered across his narrow skull, and was still damp, cleanly furrowed by his comb. Once he raised his hand to scratch his scalp, but caught himself.

He was wearing his best suit. The

cloth was still warm from the careful pressing he'd just given it. He looked down at his shoes, raised his feet one at a time, and rubbed them free of dust against his calves. Then he beat the backs of his pant legs with a few strokes of his big hands. After that, he stood without moving, the suitcase beside him.

The bus came down the street on schedule, and Henry saw it wasn't any bigger than a coupé this morning—just room for him and the driver. This early in the day, the dispatcher mustn't have seen any other passengers waiting.

When the bus pulled up, Henry stooped, lifted the suitcase, and got in. He nodded to the driver, whom he knew pretty well, and sat looking straight out through the windshield, pulling up on his pants to save the crease over the knees. He didn't feel like talking.

The driver did, though. He touched the shift, set the autopilot for New York City, relaxed, and half-turned in the seat.

"Got me up pretty early today, Henry," he said. "What's taking you into the big town?"

Henry grunted without turning his head. The driver waited a minute, and then tried again.

"Never figured I'd see the day Henry Spar wasn't satisfied to stay in the town he was born in."

A stubborn twist set itself into Henry's mouth. He knew better than the driver just how uneasy he was about going into town for the first time in his life. Be different if he

was a young buck, itching to cut loose a little. But the way it was, with him pretty fixed in his ways, you could expect trouble. And the driver didn't have any business talking about it.

"Shoppin' trip, Henry?"

Henry closed up one of his big-knuckled hands. "Dispatcher didn't tell you, huh?" he said bitterly.

The driver looked surprised. "Shuh, Henry, *he* doesn't know! All he's interested in is who's goin' where and when, not why."

"Think so, huh?" Henry asked, getting mad. "He looks in my head and he finds out all that, but he doesn't look for anything else. That what you're trying to tell me?"

The driver frowned and sighed. He held out a pack of cigarettes. "Smoke? O.K., please yourself."

"Something bothering you bad, Henry? Dispatcher isn't a bad guy. I never ran across a nasty one of them yet." The driver waited, and the cigarette lit up. Nobody knew for sure how that happened; it didn't matter much, as long as they lit.

The driver went on. "You've gotta look at it their way. They're like a guy with extra-good eyes. He can't help seein' farther than most people. What do you want him to do—put his eyes out so you won't feel bad? They can't keep from usin' what they got. Maybe they don't even much enjoy wet-nursin' us? Ever think of that? Maybe you ought to be kind of glad they're willin' to bother with us at all, instead of just letting us go hang?"

Henry turned his head toward the driver so fast that his hair shook out of place.

"I come home last night, and my sister wasn't there. Right in the middle of making dinner, by the looks of it, and they took her. Pot on the stove, bread on the board, waitin' to be sliced."

The driver's face twitched. His cheeks jumped in a quick wince of sympathy.

"Just you and your sister livin' there, wasn't it?" he asked soberly. "Name of Dorothy."

Henry nodded. He had his right hand held tight over his left, as if he was favoring a hurt.

The driver looked at the highway for a minute or two before he turned back to Henry. "Took her into Albany a couple of times, shopping. She was growin' up into a real woman." He looked back at the road. "You might of expected it," he said in a quiet voice.

Henry nodded again, slowly. "I might of. Guess I did. But I kept hopin' they wouldn't notice her for a while yet."

"You know better'n that, Henry. They notice."

Henry looked down at the suitcase he'd kept on his lap instead of putting it in the back. "I know. But you don't figure that way until it happens." He shrugged in bewilderment. "I figured maybe they wouldn't take her at all. She wasn't what you'd call a real pretty girl. Favored Pap too much."

The driver shook his head.

Henry sighed. "I know. I know—don't seem to make much difference to them, one way or the other." He shifted in his seat. "They just take 'em. Woman can be talking to you, or cooking your supper, or walking down the street—one minute she's there, the next she's gone; they've took her." He talked in a dull voice, holding his hands tight together.

"I notice they don't break up any families," the driver said.

"What's your name for me and Dorothy?"

"Well . . . you know what I mean, Henry. It's not the same, a bachelor and his sister. You can take care of yourself. It's not like they left any kids without somebody to look after 'em right, or anything like that."

"I'm going looking for her," Henry said with a sudden blunt note in his voice.

The driver stared at him. "*That* what you're goin' in town for?"

Henry moved his jaw forward. "That's right." He curled his left hand into a fist inside his right. "Going to ask the head one whether he knows who's got her."

The driver shook his head in complete amazement. "That don't make *sense*, Henry! You think they're gonna talk to you? You think one of *them* is gonna bother explainin' anything to one of *us*? Man, you're lucky they dispatched this bus for you! What makes you think they're gonna tell you the truth in the first place?"

The driver put his hand up to

touch Henry on the shoulder, and then pulled it back before he reached. "She might come home. Sometimes they do. I've heard about it happening. Why don't you just stay home and wait for her?"

Henry reached down and held the handle of the suitcase with all his other clothes and his woodworking chisels in it.

"Can't do that," he said to the driver. "I know what they are. I know they're boss. One of us can't do anything but ask 'em nice for a favor. Maybe I just been livin' in one little town all my life and not paying any mind to any business but what was mine. Maybe I ain't so sure of what I'm doing. But you got any women in your family?"

The driver's eyes fell, and he dropped his cigarette over the ashtray. It disappeared, and nobody knew for sure how that worked, either. It seemed kind of funny to suppose somebody did nothing but light cigarettes and clean ashtrays. "No, not me," the driver said. His voice had dropped. He looked out across the snub hood of the bus. "Courting always looked a little too uncertain, I guess. Besides, what's a man want with a family, these days?"

Henry looked at a road sign they were going by. They were only another twenty minutes out of New York. He sat back with the suitcase held on his lap. His face went back to its stony calm, and his eyes focused far ahead of the bus. "A man

does what's right, not what's easy," he said.

Henry stepped out of the bus at Uptown Terminal in New York, and saw a man start walking toward him.

Henry watched carefully as the slim, clear-skinned figure came nearer. The man's suit wasn't any better than Henry's, and he didn't have any special look on his face. But you could tell.

Henry stood waiting, the suitcase between his feet. The bus began to pull away, and the driver stuck his head out through the side window. He flashed a nervous look at the man. "Well, good luck, Henry," he said uncomfortably.

"Thanks," Henry muttered without turning his head.

"Mr. Spar," the man said.

Henry waited. He'd never been this close to one of them. They were all over, but this was the first one he could look at and know it for sure.

"You want to see Mr. Kennealy?"

"That's the head man, huh?" It was tough, talking to one of them. Henry hadn't thought about it before, but it would be. You knew you didn't have to talk out loud, but knowing wasn't proof. You talked anyway, feeling like a fool, and you knew he knew how you felt. Only you hoped that maybe you were different—maybe you had an extra-thick skull, or something—and you knew he knew about that feeling, too.

"No," the slim fellow answered. "But Mr. Kennealy can answer your questions for you." There was a funny, embarrassed kind of look on his face.

"How about you doing it?" Henry said. "You got 'em all figured out, don't you?" His hands were closed stiffly at his sides. He knew the messenger could look inside his head and see the way he felt. But it didn't do a man any good to just think mad. He had to act it, too.

The messenger stopped, as if he was trying to find the right words. "I'm sorry. Mr. Kennealy is the man to see. I'm on permanent assignment here as an adviser to visitors. I'm restricted to performing that service," he tacked on.

Henry hefted his suitcase. "If you're plannin' to pass me around from man to man, forget it. I've come to stay until I get my sister or you send me back. If you're gonna give in at all, do it now, or get rid of me fast. Nothing I can do about that, I guess."

The messenger's face turned red in the cheeks. "I'm sorry, Mr. Spar," he said awkwardly. "But I can only refer you to Mr. Kennealy. Believe me, Mr. Spar," he went on earnestly, "there's no reason for you to be suspicious of our motives."

Henry grunted. The messenger sighed and spread his hands. "There's no way to convince you of the truth, is there?" he said. He sounded like he wasn't used to the idea.

Henry just looked at him. Then

he pushed his jaw forward. "All right," he said, "no sense wasting our time. How do I get to this Kennealy fellow?"

The messenger looked relieved, but his voice was still troubled. "We have a car waiting for you. Right over here."

"Waitin' for me, huh?" Henry frowned. They had the skids all greased ahead of time. "How come a car, if you fellows are so almighty powerful?"

The messenger opened the door for him. There was even a driver. Henry couldn't make out whether he was another one of them or not. "You might not like it, Mr. Spar."

Henry climbed in. Maybe not. But you wouldn't figure they'd care, one way or the other. These people didn't have to answer to any man for the things they did. It had to figure they had some mighty good reason for being so polite to somebody who wasn't anything but a pretty fair cabinetmaker.

"All right, Simmons," the messenger told the driver. He took his hand off the door. "Good-by, Mr. Spar."

"So long," Henry said grudgingly, and the car rolled down a ramp and out of the busy terminal. They went past the other section, and he saw their travelers coming in, suddenly turning up on numbered platforms, getting their local bearings, and going out again.

He looked at the back of the driver's neck. "You one of them?" he asked.

The driver nodded without turning around. "That's right, Mr. Spar. I'm one of us."

He went through the door marked "Mr. Kennealy," and found himself standing in front of a desk with a big, shaggy-looking man behind it. Henry put his suitcase down.

"Hello, Mr. Spar," the man said. "I'm Matt Kennealy. Have a seat." Henry looked over to one side, and there was a chair, looking old and comfortable, still rocking a little bit in its hangers from coming out of wherever Kennealy'd got it. Henry brought his suitcase over to it and sat down.

You could tell this Kennealy was a boss. Whatever it was that made you recognize his kind in the first place, he had about twice as much of it as the young one down at the depot.

"Have a comfortable trip down?" he asked.

Henry gave him a sour look. "Let's not play around the bush, Mr. Kennealy."

Kennealy looked down at his thick-fingered hands, that were playing with a letter opener.

"Just trying to be polite, Mr. Spar," he said in a voice that, for all it was deeper and surer of itself, reminded Henry of the young one down at the depot, even though the two of them didn't look one bit alike.

"Well, you can see I ain't in the mood for it," Henry said. "Sorry about it, but that's the way it is,"

he added. He didn't like talking to people like this. People or anybody.

Kennealy was nodding to himself. "Yes, I *could* see," he admitted. "But I didn't. I *was* being polite, Mr. Spar."

Henry looked at him angrily. "Even if it was true—what makes you think any of us would believe you? If you can see into our heads, you can see in all the time. So why don't you stop this off-again, on-again stuff? You're better'n us, and I guess we'll all admit it. So either run us or don't—suit yourself, but don't try and have it both ways. Where's Dorothy?" He clinched his hands down over his knees and looked at Kennealy stone-faced. He hadn't meant to come out at him that way, but now he'd done it he had to go on. He thought about Dorothy, and the way they might be treating her.

Kennealy's face turned red as soon as Henry thought of that. His eyes dropped and he fumbled with the letter opener.

"No," he mumbled after a while, "you're wrong."

Henry settled back in his chair and folded his arms. He guessed the look on his face was answer enough to that. Even if this hadn't been one of the people who didn't need words to be talked to.

Kennealy got his upper lip between his teeth and worried at it for a minute.

"You don't know much about us, Mr. Spar."

"I keep to myself."

"Mr. Spar, we try not to disturb your people's lives, too. We do as much as we can to let you live the way you're accustomed to."

"It don't look that way to me, Mr. Kennealy."

Kennealy spread his hands out flat on his desk blotter and looked down somewhere near them. "I know. It can't be helped. If we didn't try, there's no telling what would happen between your people and ourselves. But when we do, both sides know it's just a joke." He shook his head and sighed. "It can't be helped," he said again. He looked up. "Mr. Spar, I haven't had any practice in being tactful. This isn't my regular job. Dorothy's with my son."

Henry didn't say anything for a long time. His eyes got a blank and far-off look in them.

It was hard to think. He'd raised Dorothy ever since she was five. There was twenty years' age between them—in some ways, she was more like his daughter. That didn't matter so much. He'd feel the same way if it happened to any young girl he knew. Maybe he wouldn't go looking for her—it wouldn't be his duty. But he'd feel the same way.

"I wanted to talk to you first, Mr. Spar," Kennealy said into the quiet. "As the groom's father."

Henry lifted his head up. "They married?"

Kennealy's face turned red again, but this time he was mad. "What did you expect?" he barked. His

heavy shoulders bunched up under his coat. "What kind of a—" He stopped, shook his head, and cleared his face up. "Never mind," he said in a quiet voice. "I know what kind of a mind you've got. You're human. I don't blame you for not seeing things clearly, under the circumstances."

"Meaning what?"

Kennealy took a deep breath. "Mr. Spar, we're human beings. We raise our children, too. If that sounds foolish to you, I can't help it."

Kennealy leaned forward. He said each word as if it was the most important one in the world, and each one made him madder at Henry.

"We came out of your stock—and not so long ago. We're not something that dropped out of the sky or burst out of the ground. We've got ten thousand years of the same culture behind us. We've got the same history—the same forefathers; the same traditions; the same roots. We have nothing of our own. We have only our human past, and our human natures. You're the ones who see us as a separate race. We don't. We can't.

"We look back, and see ourselves as a part of the same human racial tree. We can trace ourselves back to the same proliferating ooze that you can. But you look across, and see only a new branch, standing away from you, and you say we're different—we're separate.

"Well, Mr. Spar, we're 'them,' we're 'the other ones,' to you. You

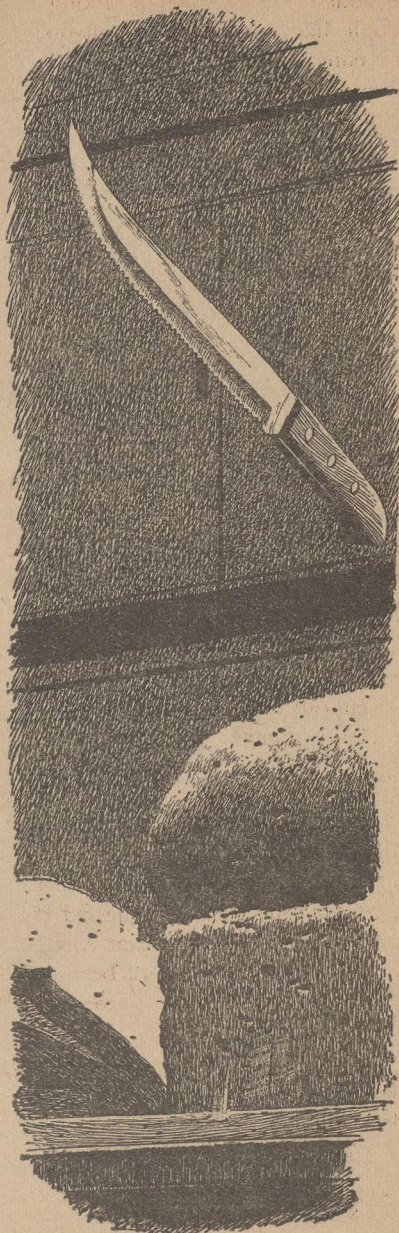

haven't given us a distinct name, and we can't think of one either; we don't want to, and maybe, deep underneath, you know better, too."

Kennealy looked across the room at Henry, and you could see he was just barely hanging on to himself.

"I raised my boy the way you would have. I watched him walk for the first time—does it make any difference whether he did it on his feet or some other way? I sent him to school. I played with him. I wanted him to marry a girl I'd be proud to call my daughter. He did."

Kennealy beat his heavy hands together. "If I was one of you, and you came to me saying the things you've been thinking about my son and your daughter, I'd punch you in the mouth."

"Well, come ahead," Henry said tightly, getting up.

Kennealy waved him back. "Oh, sit down, will you!"

Henry stuck his jaw out. "No! You want to fight, come ahead."

Kennealy's eyes turned a smoky red. His face got tight. "*Sit down!*" Something rammed into Henry's chest and shoved him down in the chair.

"And you can claim foul all you want to," Kennealy growled. He got up and paced back and forth behind the desk. "I've tried to keep it decent," he muttered, looking as mad at himself as he was at Henry. "The kids deserve a close-knit family behind them." He stopped suddenly and looked at Henry.

"Look—I'm sorry. I've got a

rough temper. It's the Irish in me. I didn't want to start anything. I figured we might even wind this up by shaking hands." He looked at Henry again and shrugged his bulky shoulders. "O.K., I've spoiled that. And you're no help, either."

He sat down. "O.K. We're at loggerheads good and proper. Suppose you go down and see the kids. They're in Trenton. You want to go?"

Henry looked at him with his hands curled up into knobby fists.

"All right," Kennealy said. "So you *don't* have to talk. O.K. The car's downstairs. Simmons'll take you down to the station."

Henry stood up and lifted his suitcase. He looked hard at Kennealy. "What're you gonna do if I take Dorothy back with me? You gonna let me?"

Kennealy shrugged, his eyes looking sad. "I don't know," he said. "It depends. Find out for yourself." He picked up the letter opener and stabbed it deep into the desk. As soon as he pulled it out the wood closed up, and he stabbed it in again. "We would have talked to you first, if we could have, you know." He looked up. "Good luck."

"Thanks, Mr. Kennealy," Henry said, his thin mouth twisted up at one corner. He wondered how many of them had been listening in, and he wondered what they thought. They knew what he was thinking.

He walked out of Kennealy's office with his suitcase bumping against his leg.

He settled down in the plush-covered seat of the old coach, and put the suitcase on the floor beside him, setting it so it wouldn't fall over.

The conductor came down the aisle, collecting tickets. Henry held his out, but the conductor shook his head. "That's all right. Save it. Mr. Kennealy's compliments."

Henry knew the conductor couldn't help it, but he got mad anyway. There wasn't any other way he could take it out. He slapped the ticket into the conductor's hand and sat facing front, his eyes feeling hot, as the train moved out of the station.

As soon as the train got all the way over the bridge into New Jersey, it began to change. Henry'd heard stories about it, but he hadn't taken much stock in it. When the windows began to run and turn colors, and the floor and ceiling sagged down and heaved upward, he had to hang on to the arms of his seat and close his eyes. He felt the cloth change its feel under his hands, and then it was all over. The windows were wide and crystal-clear, running one solid pane the length of the car. There were fluorescent panels in the chrome-trimmed ceiling, and the floor was some sort of shiny composition tile. The seats were foam slabs lying in chrome trays. Henry looked ahead, at a curve in the roadbed, and he could see that the train was a long, flex-jointed streamlined cylinder, run-

ning on a single rail set in a trough.

The man in the seat behind him chuckled, and Henry turned his head around.

"Somethin' funny, Mister?"

The man cut his laugh off. "I guess not, if that's the way you feel," he said. He stuck out his hand. "My name's Charlie Hopkins. Representing the Allied Novelty line—pen and pencil sets."

Henry shook his hand and let go.

"I do a lot of traveling," the salesman said. "I'm used to it. Guess you're not. It happens every time you cross a state line—oftener, sometimes," he explained. "Depends on how people feel. Now, up here in this end of Jersey, they're all for progress and being modern. Look out at those factories."

Henry looked through the window. The train was running between a refinery and a chemical works. Everything was shiny chrome and colored plastic panels. Everything gleamed; the smoke and fumes pouring out of the chimney tops was disappearing as soon as it hit the air.

"Now, out in the Middlewest, they've got stretches where one town's just like another; old houses, lawns, trees along the streets, old drugstore with a marbletop soda fountain and wire chairs. One town after another, just exactly the same as the last. Only the names're different, and even they've got the same sound to them. I still get confused.

"Sorry if I made you mad, laughing at you. I was just thinking back to the first time it happened to me.

It's sort of a gag around the office, see? They send you out—and they don't tell you. Man, when I felt my seat melting under me, I thought I was dead. I came near to—”

Henry grunted and turned back around. He closed down tight on his teeth.

They could do anything they wanted to. They had the whole world to fool around with—and the people in it, too, who couldn't help themselves. They could rip the roof off from over your head, and pick you up and set you down somewhere else. They could be a thousand miles away and know what was in your head. They could take the girl you'd raised from a child—without asking; without a sign or a sound, except for a knife suddenly dropping on the breadboard in an empty house.

He got off the train at Trenton, put his suitcase down on the platform, and waited while the train pulled out. He knew his hair was mussed up, and his suit had wrinkles in it, but they could just stay that way. When he saw Dorothy waiting on the other side of the right-of-way with a young fellow that must be Kennealy's boy, he picked up his suitcase and walked through the underpass. He put his feet down hard on each of the steps up to the other platform, and when he got to Dorothy and the boy he just dropped his bag with a thump and waited for somebody else to start talking.

Up close, he could see that Dorothy was looking prettier than she ever had in her life. She had a dress made out of some kind of pale-blue material that brightened up her hair color just enough so it looked like a good blond. It did something to her eyebrows, too, and her eyes, he guessed. She was looking straight at him, with her chin pushing forward, and you somehow didn't much notice that thinness to her nose unless you knew to look for it. She had her hair combed in some fancy way that showed off the good shape to her head, and she was wearing lip rouge.

He looked at Kennealy's boy. He looked too much like his father to be handsome. He hadn't put on the weight yet, but he had the big, flat-looking nose and the oversize ears. He looked a little worried, but he wasn't ashamed, or scared.

“Hello, Henry,” Dorothy said, sounding a little uncertain, too, but calm under it. She took hold of the boy's hand. “Henry, this is Tom. We got married late yesterday afternoon. We wanted to tell you, but I knew how you'd act about it.”

“How are you, Mr. Spar,” Tom Kennealy said, holding out his hand.

Henry looked at the hand for a minute, but he wound up taking it. He looked at Dorothy. “So that's the way it is. I thought maybe his father was lyin' to me.”

Tom's face got an angry look to it for a minute, but he held his temper in.

“Henry,” Dorothy said, “I'd ap-

preciate it if you were polite." She pushed her chin forward a little more. "I can see your side of it, but there's ours, too."

"Maybe," Henry grunted. He looked at the Kennealy boy again. "Maybe it might of been more polite for you to come and talk to me, if you had your eye on Dorothy."

"Mr. Spar, she was already gone. And she's already told you she knew what you'd say."

"Already gone, huh? Just like that. You reach out and grab her; pull her out of her home and bring her down here. And then you say 'Darling, will you marry me?' and the next day you're married and you figure it might be nice to tell her brother. Is that it?"

Tom Kennealy got that uncomfortable look in his eyes that his father and the messenger at the depot had.

"Mr. Spar, anything can sound bad if you want it to. I didn't kidnap Dorothy; anyway, I didn't plan it or do it deliberately. It wasn't down here that I brought her, by the way. It was England. I was working on a paper at Oxford. My mother lives here."

Henry felt his big fingers curling. "Didn't do it deliberately, huh?" he said in a tight-throated voice. "I guess she went to Oxford, England, of her own free will?"

"No, I didn't, Henry," Dorothy said, just as stubborn as he was. "But I stayed of my own free will. I didn't have to be with Tom very long before I knew I wanted to."

She looked Henry square in the eyes. "A woman knows her proper man, Henry. And don't you think different." She reached over and took the Kennealy boy's hand again, holding it tight.

"We don't have waiting periods, Mr. Spar," Tom Kennealy said. "We don't get married unless we're sure it's right."

"And you're sure, huh? Well, I guess so. And I guess she can read your mind, too? She can be just as sure?" Henry felt his teeth settling hard against each other.

Dorothy pushed herself forward and faced him up close. Her eyes were snapping like a whip. "Henry, that's enough of that! You can't take care of me forever. You can't keep me in the house until it's too late for me and all I'm good for is to be your housekeeper. How many boys are there back home who were courting me? You've got to be like . . . like Cleopatra before they'll even speak to you." Dorothy put her foot down hard on the platform. "You know where we got married? In Scotland, that's where. In a little church with the mist over the sea and the sun just breaking through. When was I ever in Scotland, Henry? Or when did I hope to go? And we're going to Hawaii tonight; and this is a Paris gown—and a man in Rome did my hair this morning."

"That's a good price, I guess," Henry said.

Dorothy took a step back. Her

face went pale for a minute, and then her mouth went thin and bitter. She looked at Henry like he was something she didn't recognize.

"Mr. Spar," Tom Kennealy growled.

"Yeh?"

"Mr. Spar, I know for a fact that Dorothy doesn't give a darn about any clothes or hair-dos." Young Kennealy's jaw was white at the corners, but his eyes were hurt looking. He was holding his temper down as best he could. Henry guessed the boy thought there was something more important to get across. He waited.

"Mr. Spar, I *know* Dorothy's in love with me."

"Sure. And the minute I can read *your* mind, I'll believe you. Maybe I'll even decide she means something to you."

"At this point, I don't care whether you do or not, frankly," Kennealy said, his voice as ready to break as a cable under strain. "But she means something to me. She's my wife. I married her. And I'm going to stay married to her. Look—if she'd eloped with some young buck in a tin lizzie, would you be acting like this toward her? I saw her. You know what happens then, Mr. Spar? To one of us? It's quicker than thought. I saw her, and she was there. In England. With me. I've seen my share of women. This was the only one I wanted. So there she was. And I was lucky—she didn't want to go back. And she would have, if she wanted to. What makes

you think we haven't got laws? What makes you think that with each of-us having a million minds looking into his own, we can possibly have criminals or psychotics? If she hadn't wanted to stay, she wouldn't be here—she'd be back home with you, darning your socks."

Henry looked at Dorothy, but she wouldn't even look at him.

"All right," he said, looking back to Tom Kennealy. "You're boss." He picked up his suitcase and turned away. "You can come back home whenever you want," he said to Dorothy and went down to wait for the train back.

He found out he'd rather get off the train in Jersey City and walk across the bridge into New York, but that was about all. He turned up back in his cottage the next morning, and nobody thought anything much of it. He went to work in the shop, and got docked a day's pay for being out. Nobody talked about Dorothy. They didn't make any point of not talking about her. They just didn't, and after a while Henry stopped noticing it. He settled down to his work, and made his own bed and cooked his own breakfasts.

One day the house got bigger again. When there was a knock on the door, later that night, he just opened it and stood in the doorway, with the light streaming out from behind him and over Matt and Tom Kennealy, along with Dorothy.

"Hello, Mr. Spar," Matt Kennealy said.

Henry nodded. "Come in. I can't stop you. It's no surprise. I saw the nursery."

Dorothy kept her arms tight around the blanket-wrapped bundle in her arms. She looked worried, but under that she looked fine. Her face had rounded out a little, and the little pinches over the bridge of her nose were gone. She came close to being beautiful.

"Thanks, Mr. Spar," Matt Kennealy said. "But we can't stay. It isn't comfortable." He shrugged his shoulders and grinned a little. "Both of us came down with Dorothy because Tom doesn't know how to drive a car." He grinned again and shook his head. "It's always the same. Babies don't like change. They want things exactly the way they are. This one's as stubborn as they come. He doesn't mind riding in a car—that's not what he considers a change. But he kicks up the very devil of a fuss if Tom or I try to do so much as look around while we're near him. That makes Junior see things he's not ready for—so he deafens everybody for miles around with a yell that you *can* hear in Madagascar, if you're listening for it."

Dorothy came into the doorway. She smiled at Henry. "You've got quite a nephew, Henry. They tell me there's nothing special about him, but I've got my doubts. Anybody with Tom's temper and Pap's stub-

bornness in him can't be just ordinary."

Henry didn't smile back, and after a little while Dorothy's face went back to its worried look. "I'd like to stay here with you until he's grown enough," she said.

Henry grunted. "Go or stay. Nothin' I got to say about it. What's the boy's name?"

"Billy."

"Billy, huh? Guess it's a good one. I saw your clothes and stuff in the bedroom next to the nursery. Must have figured I'd let you."

"We can take them out again, Henry," Dorothy said.

He shook his head. "No. No, I told you you could come home."

"Thank you."

"Half of what's mine is yours. Nothing to be thankful for." He turned around and went back to his chair beside the fireplace, facing away from the doorway.

He heard Dorothy kiss her husband. "Good night, Tom."

"Good night, Honey. See you tomorrow?"

"I don't know. Better give me a day to get settled. Make it the day after."

"All right. I'll miss you."

"I'll miss *you*. Now you'd better be getting back—you've got at least four miles of road to cover before you're out of our offspring's range." She laughed softly, and Tom and Matt both chuckled with her.

"Good night, Dorothy," Matt Kennealy said.

"Good night, Dad. I hope your



driving improves with practice."

There was another general chuckle.

"Good night, Mr. Spar," Matt Kennealy said.

Henry grunted an answer. There was a minute's quiet, and then Henry heard Matt sigh, and mutter something annoyed. But after a minute the door closed, and Dorothy came into the room, carrying the boy. She sat down opposite him, and looked into the fire.

Henry picked up the paper and started reading it.

"Anything to say, Henry?" Dorothy asked after a while.

Henry looked up. "That's a pretty coat," he said, and went back to reading.

At breakfast the next day, he looked down at his plate. "What's that?"

"Scrambled eggs and onions," Dorothy said. "It's good."

He took a sip of his coffee. "Pick up anything else from being around them?"

She took a slow breath. "A few things." She moved her fork around on her plate.

"You've got the sound of a city woman to your talk, I notice. I suppose you know a whole string of foreign languages, too, with all that traveling?"

Her mouth was drawing out slowly, getting thin and tight. "A little of some. Tom does most of

the talking when we need it. I'm still learning."

"Learn how to look inside his head, yet?" He watched her closely.

Her hand closed down hard on the fork. "As much as any married woman with her husband." She looked up, the anger showing plain in her eyes. "Maybe a little more. One of us can do a few things, if she's shown how." She put her fork down. "Henry," she said, "we're going to be living more or less in the same house for the next five years, at least. Maybe we won't . . . maybe I made a mistake in coming back. But I'm here to try it. Don't make it harder on yourself than it has to be."

Henry shrugged, feeling a shadowy kind of a disappointment inside him. She'd made it plain enough, but he'd been hoping she'd maybe wanted to come back because she saw she was wrong.

"Not gonna be hard on me at all," he said. "You go your way, I'll go mine."

"That's the way you feel."

"That's it." He pushed the plate aside without touching the eggs, got up, and left the house to go down to the shop.

A few days a week, he slept in the room next to the nursery, minding the boy while Dorothy was away. He went with her once, after hiring a woman to come over, when she took the bus out to the crossroads near Aiken's Hill. He'd watched her climb up it in the twilight, and stand

at the top. Then she was gone, and an early star shone through the place where she'd been standing. He'd waited until she came back, hours later, looking rested and quiet, but he'd never gone again. And that was the way they slowly settled down to living. And a few years went by.

There were books in the house, and Dorothy got a music player. He didn't read the books. He had to hear the music, sometimes—he got to like some of it—but he didn't know how to work the player and didn't want to.

The boy grew. He was quiet for a long time. Dorothy said he was learning to talk. And after that he started coming and going around the house. He never went too far, because he didn't know his bearings for very many places, and Henry got used to having him turn up in odd corners.

Then he learned to speak. He sounded like Henry sometimes, and sometimes like Dorothy, at first, but after a while he smoothed out and sounded like somebody in his own right.

Dorothy stopped having to go all the way out to the hill before Tom could reach her, but she still went out to see him, and that was fine with Henry.

And one day, when Henry was down in the basement, working on a new chiffonier for one of the bedrooms, the boy turned up beside him and stood watching.

Henry didn't mind. He kept on

planing the leg he was working on, feeling the blade cut smoothly through the maple. Then he set it up on the lathe and laid out his chisels.

"Ever see this before, Boy?"

Billy shook his head. "Never watched before. Looks interesting."

Henry grunted. "Dunno if it's interestin' or not. I like it."

He switched the motor on, set his chisel solidly on the T, and made his first cut. Working carefully, he rounded the end eight inches of the upright.

"That part's going to be the leg, huh? And the rest of it's going to form one corner of the chiffonier," Billy said.

"You know as well as I do, Boy."

"Guess I do. Uncle Henry, can I have that piece of wood over there?"

Henry looked over. "That red one? No, Boy. That's mahogany. You don't want to fool with that—it's too good a piece of wood. Take that—"

Billy'd already picked up the piece of scrap pine. He looked at Henry, and carefully took the tools he knew it was all right to use.

That was one thing, anyway. He could know how to use tools, and there wasn't any trouble about him hurting himself. Henry forgot about him and went back to cutting out the leg.

After that, Billy was down in the shop a good deal of the time. It wasn't long before Henry trusted him with the lathe; it kept the boy

busy, and Dorothy didn't mind.

Billy didn't do much with it, though. He just turned wood into all kinds of shapes for a while. Henry decided it was just another way of playing, for a while, but after a month or so Billy began pestering him.

"Uncle Henry — what's wrong with this?"

He was holding up a wooden ball he'd turned. Henry grunted, put his paper down, and took the ball in his hands.

"Looks all right to me, Boy," he said. "Good job, matter of fact." It was as true as you'd want for freehand turning, and then some.

Billy shook his head. "It looks wrong. The way the grain runs."

"Well, that's something else, Boy." He'd turned it some funny cross-grained way.

So Henry taught him about grain. He showed him how to catch the flow of it in the shape of the wood—how to bring it out, and how to bury it. He taught him about finishing—about treating it so it wouldn't crack out as the piece dried. He taught him about how wood is alive a long time after it's out of the tree, and how you have to know which way it'll swell, and which way it'll shrink.

And when Billy asked if it was all right to use the piece of mahogany if he promised to replace it, Henry let him.

Dorothy came into the parlor. "Henry?"

"Yeh." He knocked the dottle out of his pipe into his palm, and dropped it into a wastebasket.

"Henry, look at this."

He grunted and looked up. She was holding a wooden shape in her hands. "Billy just gave me this."

Henry grunted. "Let's see it." Dorothy handed it to him.

It felt good in his hands. It was some kind of complicated shape that seemed to turn itself in his hands all by itself. It glowed with the soft amber color of beeswaxed mahogany. The tight grain shot through it, flowing in long bands along one surface, jabbing up under another. He set it down on a table under a lamp and turned it around slowly, and couldn't tell from the shape and shifting glow of it when he'd gotten back to his starting place. The shape just seemed to flow on and on.

Henry straightened up slowly. "Something," he said. "The boy's got a touch of something."

Dorothy picked the shape up in her hands and held it again.

"It's more than just a touch, Henry. He came up to me and just handed it to me. He didn't make any fuss over it—but I could tell. This is what he wants to do."

"Don't see why not. He's got a good hand for wood. Man with a good, skilled hobby has something he can be proud of. The boy'd make a good man, down at the shop. But I don't suppose that's exactly what they have in mind for him." He gave her the bitter look that had

been passing between them for years, now.

He saw it make her mouth thin out like it always did.

"This is more than a hobby," she said. She got suddenly angry, the way she did, sometimes.

"Henry, they don't have anything of their own. They don't have *anything*. They borrow it all from us, and try and make it do. They waste themselves keeping this world as close as possible to what we want. But what else can they do? They don't know what their kind of world should be, yet.

"Billy's the first one. You don't know how rare it is for one of them to know how to work with his hands—how to take something that's of the Earth and shape it so it points the way to wherever they're going. They didn't have that, up to now." She held the shape up. "This is the first thing they've ever made that's of themselves."

Henry's mouth jerked up at one corner. "You suppose now your Tom'll love you for sure?"

Dorothy looked like he'd hit her, for a minute. "You're not *ever* going to give up, are you? You're just going to be like that. You're never going to believe in what you can't taste, touch, smell, feel or hear."

"That's right," he grunted. "That is what a person is. I don't know about them, but I know about me. I know what I am, and what's right." He started into the living room. "That's the difference be-

tween them and us," he said. "We know. They don't. They go flibbertygibbeting over the world, because they got no place to light. They keep fussin' and fiddlin' with things, trying to make 'em better, and not knowing what better is. They got no place to begin from. Like that thing Billy made. It goes on and on, and it never looks the same way twice. It's got no place where a man can stop and say: 'Now, *that's* what it looks like. *That's* what it's supposed to be.' You know what they are? They're lost—they're every one of 'em lost in the dark."

He sat down in his chair and picked up his paper. "And what's more," he said over his shoulder, "they're goin' to stay lost." He saw Billy turn up in the chair across the fire, sitting curled up with his chin

on one armrest, just looking quietly into the fire. "They're not ever going to have anything that's strong, and solid, and useful," Henry finished up.

He looked at the boy, and the boy turned his head and looked back at him.

Not a one of them was any good, Henry thought to himself. Not a one of them. Best thing a man could do was ignore 'em as much as he could.

But the boy, now— Well, the boy was a little different. He wasn't more than half one of them. And he was pretty good with his hands, which most of them weren't.

He gave the boy a sort of gruff wink, and the boy smiled back.

Might be able to do something with him.

THE END

THE ANALYTICAL LABORATORY

One of the problems inherent in science fiction is that each story actually is a brief glimpse of an alien world-scene. The longer the story, the more chance the author has to give a feel of reality—a texture of living fabric—to his world-picture. Result: a longer story, all things—and authors!—being equal, will have more satisfying effect for the reader. That effect will, inevitably, bias the results in the Lab here. It's darned seldom a short takes first place. This time, of course, with "Double Star" running, it would have taken something slightly Hollywoodian colossal to grab first. And the scores stacked up thus:

(Concluded on page 108)



THE CHOSEN PEOPLE

The essential trick in getting a puppet to stand on its own feet is to pull the strings so delicately it never learns it isn't!

BY ROBERT RANDALL

Illustrated by van Dongen

The hard, savage mandibles of the hugl slashed at Kiv peGanz Brajyd and missed. Kiv jerked his hand out of the beast's way just in time. Again the hugl lashed out—and this time, it connected. The powerful jaws came together, and Kiv's blood spurted down over the monster's head.

"Damn!" Kiv snapped, irritated. The animal's little teeth had taken a nasty bite out of the ball of Kiv's thumb. Before it could snap again, Kiv dropped the animal into the little wooden box he usually carried with him for just this purpose and clicked the lid shut. "Bite you?" Narla asked.

"Yes. Nasty little beast," Kiv said without rancor. "I should have learned how to handle them by now. If they're all as hungry as this one, I can see why they're having so much trouble with them on the northern farms."

He turned the box over. The bottom, which was made of glass, permitted him to see the hugl. Clashing its jaws, the inch-long creature scrambled madly around the inside of the hard, plastic-impregnated box.

Narla iKiv geFulda Sesom, who had only recently been privileged to add the "iKiv" to her name, looked with interest at the little box in her husband's hand.

"What's so different about it, Kiv?" she asked.

"The armor," he told her. "It's black. I've never seen a black one before. All of the specimens I have at the School are brown." He wrapped his pocket kerchief around the nipped thumb and tied it.

"Take this, will you?" Kiv handed the box up to her, and she stared at it curiously. He dug his high-heeled riding boot into the stirrup and pulled himself up to the saddle.

"Jones will be interested in that specimen," Kiv said, as they guided their deests out of the roadside thicket where they had paused for midmeal. "Put it in the saddlebag," he told her. "And be sure to remind me to show it to Jones as soon as we're back at the School."

She nodded and reached back

obediently to stow the box in the leather pouch. Kiv felt a glow of pure pleasure as he watched the smooth play of her muscles under the fine golden down that covered her skin. Since she was clad, as he was, in the traditional Nidorian dress—sleeveless vest and thigh-length shorts—he had no thought about the beauty of her clothing; it was her own beauty he saw. She might not be the most beautiful girl on Nidor, but she approached Kiv's ideal so closely as to be almost indistinguishable from it.

He tipped his head back and squinted at the eternally clouded sky. The Great Light was almost at His brightest, spreading His effulgence magnificently over the green countryside. It was a little after midday.

The Earthman, Jones, said that the Great Light was a "blue-white star." Just what a star was, Kiv didn't know; they were supposed to be above the cloud layer. Some of the things Jones said didn't make much sense, Kiv thought.

"We've got about an hour's ride ahead of us," he said. "We should be getting along. I can't wait to see the School again; this vacation seemed to last forever."

"You've been terribly anxious to get back to work, haven't you, Kiv? I felt it all the time you were home. You seemed so anxious to leave that I almost apologized to your parents."

"The School is very important to me, Narla; you know that. It's a

great honor to be chosen to study with the Earthmen."

"Of course; silly. I know."

He snapped the reins, and his deest broke into a smooth trot. Narla's mount kept pace easily with him.

"How long will it be before you write your book?" she asked. "I mean, do you think you'll be able to get the rest of your information during the next term? It seems to me that you've covered all there is cover on the hugl already."

Kiv nodded. "I think I'm nearly done. It's going to be a rather scholarly thing, I'm afraid; no one is too interested in the life cycle of the hugl. If anyone were, he would have done the job years ago."

"I know. But even if your work isn't terribly consequential, it's still good training for you," Narla said. "As the Scripture says, 'The observation of life permits one to attain an inner peace.'"

Kiv frowned. "I'm not sure the Scripture means that. I don't think it means lower forms of life."

"Don't be silly, Kiv. It says 'life,' doesn't it? And if a hugl isn't alive, I don't know what it is."

Kiv was silent for a while, resting easily in the saddle while the swift pace of the deest carried him over the matted turf of the road.

"It may be so, he said finally. "Certainly Jones was all in favor of my studying the hugl for my book. And I don't think Jones would permit anything that violated the

Word of the Scripture. Hoy! What's that?"

Narla, startled by his sudden change of tone, glanced quickly at him. Kiv was pointing down the road with one golden arm outstretched.

Someone was standing in the middle of the road, just where it forked. As their deests drew nearer, they saw that it was a man in the familiar blue tunic of a priest. He held up his hand as Kiv and his wife approached. The two riders pulled their animals to a halt and bowed their heads reverently.

"The peace of your Ancestors be with you always," said the priest ritually.

"And may the Great Light illumine your mind as He does the world, Grandfather," Kiv and Narla chanted together.

"How may we serve you, Grandfather?" Kiv asked.

"Did you intend to cross the Bridge of Klid?" the priest inquired.

Kiv nodded. He took careful notice of the other man. The priest was not much older than Kiv himself, but his bearing had all the dignity that was proper to his office.

"We were going to use the bridge, yes," Kiv confirmed.

The Grandfather shook his head. "I'm afraid you'll have to use the Bridge of Gon and go through the city, my son. The Bridge of Klid is being repaired."

Kiv barely managed to conceal a frown. Another delay! And, of

course, the proper thing for him to do would be to offer his services in the repair work. He began to think he would never get back to the School.

"If you would do so," the priest said, "it would be appreciated if you could go to the nearest communicator and tell the City Fathers that we need more men to help repair the bridge. Give them my name: Dom peBril Sesom."

"I'll be glad to. What happened, Grandfather?"

"A section of the roadbed near the center has collapsed. We want to get the job done before the evening traffic begins."

"I see," said Kiv. "Very well, Grandfather. My wife and I will go on to the city and get hold of a communicator. Then I'll come back and help you build. My wife can go on to the School."

"The School?" The Grandfather looked politely astonished. "Are you, then, students of the Bel-rogas School?"

"We are, Grandfather."

"Then I cannot permit you to work on the bridge," he said. "Your studies are of greater importance. Any man can work on a bridge; only a few can assimilate the Scriptures and the Law—and even fewer are worthy of studying at Bel-rogas. Go and give my message to the City Fathers and then go on to the School."

"Very well, Grandfather," Kiv agreed.

The priest raised his hand in

benediction. "Go, with the blessings of the Great Light, and Those Who have passed on to His realm."

Kiv and Narla turned their deests and took the southern branch of the road toward the great city of Gelusar, a long ribbon of a road curling through the gray-green farmlands.

"Nuisance," Narla said.

"What is?" Kiv asked pleasantly.

"This business of treating us as if we were likely to melt in the first rainfall. Did you see the way he looked at you when you said we were from the School? 'Your studies are of greater importance,'" she mimicked. "I cannot permit you to work on the bridge.' And I'll wager that's what you wanted him to say, too. You didn't want to work on that bridge, but you had to offer for the sake of courtesy. You just want to get back to Jones and the School."

"Narla!" He speared her with an angry glance. "When a Grandfather tells you something—"

"I know," she said, crestfallen. "I'm sorry."

They rode on in silence for a while. The road to the Bridge of Gon was a narrow, winding one, and Kiv's deest required considerable guiding at each turn. A stupid animal, Kiv reflected, as for what seemed the twentieth time in the last ten minutes he put pressure on the reins to turn the deest.

"Narla?" he said after a while. "Narla, that's the second time I've

heard you question a Grandfather's instructions since we left my parents. And I don't like it—not at all."

"I'm sorry, I told you. Why can't you leave it at that?"

"But the tone of your voice when you mimicked him," Kiv protested. "Don't you know what respect means, Narla?"

"All I wanted to know was why we're so sacred, that's all," she said impatiently. "As soon as he found out we were from the School, we were suddenly too important to help repair the bridge. *Why?*"

"Because we've been chosen, Narla. Jones and the other Earthmen have come from the sky—from the stars, Jones says, whatever *they* are—from the Great Light Himself, for all we know. They're here to teach, and we must learn. Only a few are chosen. And the Law, Narla—that's what's important. Grandfather told you: anyone can fix a bridge. We're special."

"I'm sorry," she said a third time. "I'm only a woman. I don't understand these things."

Be patient, Kiv thought. Patience and understanding, that's what a woman needs.

After a long spell of hard riding, they eased up on their tired deests to rest them for the final lap of the journey.

Narla had said nothing all this time. Finally she asked: "Is Jones *really* from the sky? I mean, is it true that the Earthmen come from the Great Light?"

She keeps asking questions like a small child who's too impatient to sit still, Kiv thought. It's been a long trip; she's tired.

"I don't know," he said, keeping his voice quiet and matter-of-fact. "I don't see how they could come from Nidor, and the Grandfathers tell us that the Earthmen do not lie. The Grandfathers have accepted the Earthmen."

"And, there, we accept them," Narla completed.

"Of course," said Kiv.

And then the first scattered outskirts of the City of Gelusar came into sight.

They rode into Holy Gelusar—founded by the Great Light Himself! The vast, sprawling city was the center of all Nidorian culture. For two thousand and more years, it had stood almost unchanged, spreading out radially from its center, the Grand Temple, where the mighty Council of Sixteen Elders ruled the world of Nidor according to the Scripture and the Law.

Kiv and Narla guided their deests through a crowded thoroughfare that led toward the heart of the city, looking for a public communicator. They finally found one near a shabby little side street that shot off toward the river. Kiv dismounted and went in.

There was a chubby little man behind the counter who took Kiv's request.

"This is a local call, then, not long distance." The little man was

talking to himself more than to Kiv. "That will be three weights and four."

Kiv paid the attendant, walked over to the booth, and closed the door. Then he picked up the microphone and flipped the switch.

"Communications central," said a voice from the speaker.

"This is Kiv peGanz Brajjyd. I want to give a message to the Uncle of Public Works."

"One moment." Kiv heard a series of clicks over the speaker, and then a new voice spoke.

"Office of Public Works. What is it, please?"

"I have a message for the Uncle from Grandfather Dom peBril Sesom at the Bridge of Klid. He asked me to tell you that he needs another squad of men if he's going to get the bridge repaired for the evening traffic."

"And your name, sir?" queried the speaker.

Kiv identified himself, was thanked, and cut the connection.

Outside the communications office, he found Narla talking to an elderly man, obviously a farmer, judging by his dress.

"... And I tell you, something has to be done!" the farmer was saying. "My sons and their families are fighting desperately now, but if we run short of Edris powder, there won't be a crop this year."

Narla said: "It sounds bad. And you say there are other farmers having the same sort of trouble?"

"Plenty of them," said the farm-

er. "The Great Light alone knows how many million of those hugl are chewing up the countryside out in my sector."

"Your pardon, Aged One," said Kiv, even though the farmer was not really old enough to deserve the flattering term. "What's this about the hugl?"

The man turned. "They're eating my crops! They're swarming again. You see, the hugl travel in vast swarms, eating and stripping everything in their path. And that goes for animals, too. Everything!"

"I realize that," said Kiv patiently, "but I hardly see that it's anything to worry about. This happens periodically, doesn't it?"

"Never like this," said the middle-aged man. "It seems to get worse all the time." Kiv noticed for the first time that the man looked tired and travelworn. The fine golden down that covered his skin was heavy with road dust. Kiv realized suddenly that he and Narla probably looked about the same.

"I've come to talk to one of the Elder Grandfathers," the man said. "One of my own clan, with whom I schooled as a boy. We need help out there." He took a deep breath. "May you have many children to honor you." Then he turned and headed into the communicator office.

"And may your children and their children honor you forever," Kiv called after him.

He remounted his deest, turned the animal's head gently, and trot-

ted with Narla down the thoroughfare toward the Grand Temple.

"He seemed quite worried," said Narla.

Kiv grinned. "They all do. If you'd had as much contact with farmers as I have, you'd understand. Every so often, the hugl march, and when they do, the farmers worry. Edris powder is expensive, but it's the only thing that will control the hugl. Fortunately, it *does* control them. It's a nerve poison, and it kills within a few minutes."

Narla smiled back at him. "The way he talked, you'd think that the hugl were going to eat up everything organic in the whole world."

"Remember, darling, to a farmer, his farm *is* the whole world."

"It's almost as if the hugl wanted to destroy us," Narla said, her voice changing suddenly.

Kiv looked at her. "What do you mean?"

"According to the Scripture: 'To destroy a thing, one must cut at the root, and not at the branch.' And certainly, the farmer is the root of our economy."

Kiv laughed aloud. "I see what you mean." He smiled. "It just proves that all living things obey the Law. But I'm sure the hugl don't do it consciously."

They rode on through the city, watching the peddlers and vendors excitedly hawking their wares. They passed by the Central Railway Terminal, where the little steam engines

chuffed and puffed their way across the ancient overhead rails.

"We could have been to the School by now," Kiv complained. "Having to detour through the city like this is an awful waste of time."

"What would you have done?" Narla asked, a smile crinkling the skin around her eyes. "Swim the river where the Klid Bridge was out?"

Kiv chuckled. "It might have been cooler at that," Narla went on. "I'm going to need a bath badly by the time we get to the School. It's so much dustier here in the city." She said nothing more for several minutes, but when the Grand Temple came into view, she said softly, "Should we go in, Kiv?"

Kiv thought of the interior of the Temple—the vast rows of kneeling stands, the brilliant white glare of the altar, where the beams of the Great Light were focused through the huge lens in the ceiling, and the restful silence of the flickering incense candles.

But he shook his head. "No," he said. "We should have been at the School by now." Then he caught the little spark of petulance that flickered for a moment in Narla's eyes, and added, "We'll come back on the next Holy Day. I promise."

She nodded in silent agreement.

"That's our road," Kiv said. "Over there." The Bel-rogas School of Divine Law was situated five miles outside the city of Gelusar, up a long, twisting turf road. They

trotted out to where the road began, and started up the hill.

Jones was a tired-looking man with faded blue eyes and a short, stiff brown beard that provided a never-ending source of conversation for the beardless Nidorians.

"Glad to see you back," he said as Narla and Kiv entered the Central Room of the School's main building, after having stabled their deests outside. He was sitting comfortably on a bench in one corner of the big room, leafing through a ponderous leather-bound volume.

"Have a nice visit?" Jones asked amiably. "How were the folks?"

"My parents were in good health," Kiv said. "As were Narla's."

"Good to hear it," Jones said. He closed his book and replaced it on a nearby shelf. "Sorry vacation's over?"

"Not at all," said Kiv. "I didn't realize how much the School meant to me until the vacation time came. All year long I waited impatiently for classes to end so I could go back home."

"But as soon as he got home he started counting the days before School started again," Narla said. "He just couldn't wait."

"Impatient, eh?" Jones said, frowning as if considering something.

"Yes," Kiv confessed. "Impatient."

"It's been awful, Jones," said Narla. "You'd think I was a deest,

the way he's been ordering me around. We couldn't even stop off at the Temple in Gelusar, he was in such a hurry to get back."

"That's not true!" protested Kiv. "I did try to help repair that bridge, didn't I? And they wouldn't let me!"

"What bridge?"

"The Bridge of Klid. Roadbed collapsed. That's why we took the back road."

"I figured something like that must have happened. I've never seen two more bedraggled-looking people than you two. Why don't you head up to your room and get some of that dust out of your fur?"

"Good idea," said Kiv. He looked enviously at Jones' smooth skin. "You're lucky," he said. "You have all your fur under your chin."

"A mere matter of Providence," Jones said. "For so the Great Light decreed."

"And so shall it be," Narla completed.

"Come on," Kiv said. "Let's wash up."

They started to move toward the great staircase that led up to the students' rooms. Kiv felt a warm sense of being home again when he saw the thick banister of glossy black wood.

"I suppose we're in the same room as last semester?"

"There've been no changes in room assignment," Jones said.

"I was afraid of that," Kiv said glumly. He stared up at the winding staircase. "That means another



year of struggling up seven flights of stairs." He drew in a resolute breath. "Oh, well. So shall it be, the Scripture says. Let's go." Kiv took Narla by one hand, hoisted his saddlebag with the other, and they started up the stairs.

When Kiv came down, half an hour later, Jones was sitting exactly where he had been before.

"You look a lot cleaner now," Jones said.

Kiv smiled broadly. "Yes. It's amazing what a quick shower can do. But Narla's still up there scrubbing herself; her skin's glistening by now, and she still maintains she's covered with dust."

"It's been a pretty dry month. The roads are dusty."

"Don't we know it!" Kiv said. He started to sit down, then suddenly clapped his hands and dashed up the stairs. He returned a moment later, bearing the little box that had been in the saddlebag.

"I noticed this specimen on the road, when we stopped for mid-meal," Kiv said. "And forgot all about it till now, like a stupid deest." He handed the box to Jones.

The Earthman turned the box over and scrutinized the little animal within. The hugl was still frantically battering the side of the box in an attempt to escape, but it had made no impression on the hard plastic.

"You notice that it's got *black* armor," Kiv pointed out.

"Oh, yes, I see that," Jones said.

"I'm pretty well aware of what these things should look like, you know." He drew the box close to his eye and stared at the hugl.

"Beg pardon," Kiv said. He started to make a ritualistic bow of forgiveness, but Jones checked him with a quick gesture.

"All right, Kiv. I'm not offended." He gave the box a quick flip and the unfortunate little prisoner went over on his back. Jones studied the creature's underside for a moment, before the hugl managed to right itself.

"What do you make of it, Jones? Why is it black? All the others are brown, you know."

"Yes, I do know," Jones said, a trifle impatiently. But before Kiv had a chance even to begin apologizing again, Jones had uncoiled himself from the bench and was walking briskly across the Central Room.

"Come with me," he said.

Kiv followed, trying to keep up with the pace set by the long-legged Earthman. "Where are we going?"

"You *have* become impatient, Kiv. Always bursting out with questions."

Kiv smiled. Not long before, he had been criticizing Narla for the same thing. Apparently he shared her fault, since he had managed to give offense to Jones three times within just a few minutes. Had Jones been an Elder, Kiv reflected, I'd be still finishing my first ritual apology, with numbers two and

three to go. It's a good thing Jones is different.

"Here we are," Jones said. He fumbled at his waist until he managed to detach his door-opener from the belt of his shorts. He inserted it and the door clicked open.

They were in Kiv's laboratory.

"To forestall your question," said Jones, "yes, I *have* been taking care of your pets while you were gone, as requested."

"I never doubted it," Kiv said.

"I know," Jones smiled. "Pardon me when I tease you. You're just so *solemn* some times."

I'll never get used to the way he talks, Kiv thought. As if I were his brother, almost. And he's *older* than I am, by the Light! Perhaps the Earthmen will never understand that they are due the greatest respect.

Jones drew out the box containing Kiv's hugl.

"While you were gone, I started a new nest. Come here and look at it, will you?"

Kiv walked over to the cabinet near the window and peered in. It was swarming with hugl, fiercely tearing what looked like the haunch of a deest to ribbons.

And every one of them was a dark, glossy black.

Kiv looked up, startled.

"They're just like mine," he said. "Black!"

"Exactly," said Jones. "Your specimen is of a type not exactly uncommon in these parts. As a matter of fact, I collected all of these

on the farm of one Korvin peDrang Yorgen, not very far from here. His farm was completely overrun with them about three days ago. It should take these black hugl about ten days more to reach your father's farm in . . . where is it . . . Kandor?"

Kiv stared at Jones' bland, unexpressive face. Suddenly, he remembered the weary old farmer Narla had encountered outside the communications office, and how he had protested so bitterly that the onslaughts of the hugl seemed to get worse every year.

"These hugl are all over the district?"

"All over," Jones said. "They go from farm to farm. Eating. They're the hungriest creatures I've ever seen. Take a look at Korvin peDrang's farm later in the day. Right out in front you'll see a very fine deest skeleton. They picked it clean of flesh in less time than I can tell about it."

Kiv squinted into the cabinet again, watching the furious milling about of the little animals. They were marching round and round their enclosure, as if mere motion would eventually free them.

"I'll say they must be hungry." He held out his bandaged thumb for Jones' inspection. "This one I brought back took a nice chunk out of me while I was collecting him."

Jones nodded. "Oh, they'll eat anything, all right. Ask some of our farmers."

"It's funny," Kiv said. "Here I am, an expert on hugl, and the first

time the little beasts do something significant I have to be miles away! Some specialist I am; my own animals develop a new species and start eating deests, and I don't find out about it till days have passed."

He walked over and stared gloomily into the big tank where his hugl larvae lived. The little teardrop-shaped animals—"water wiggles," the farmers called them—were paddling peacefully up and down in the brackish pond water Kiv had so carefully transported to his laboratory from the nearby lake where he had collected them.

"Will these be black or brown?" he asked Jones.

"How should I know?" Jones replied. "Ask them."

Kiv smiled, concealing his disturbed feelings at Jones' flippancy. "I haven't learned their language," he said. "Or they haven't learned mine."

He looked back over his shoulder at Jones, who was staring out the window, watching the stream of radiance from the Great Light slowly die from the clouded skies. It was approaching nightfall. "I guess the poor farmers are working all day and all night to get their fields sprayed with Edris powder," Kiv said.

"They are," said Jones. "They've used so much that the supply is starting to run low. You can almost smell the Edris drifting on the wind, they've used so much."

"That's good. Hugl make very interesting beasts to study, but when

they threaten the crops, I don't feel so affectionate toward them. And it's a lucky thing the Edris powder controls them so well."

"Very lucky," said Jones. He turned to face Kiv, and there was a curious twinkle in his eyes. "But there's one other thing I haven't told you yet. The Edris powder isn't controlling these black hugl at all. Not at all."

Picture a multilegged little animal about half as long as your thumb. Now multiply it by a factor of between one and three million. Picture this vast horde of vicious, eternally hungry little monsters moving slowly but inexorably over the farmland of Nidor's one great continent.

Every lake and every pond could become a focal point of the infection, from which the predators would spread, consuming everything in their path.

That was the picture that sprang into Kiv's mind. If what Jones said was true, if Edris powder could no longer control the hugl, then... then—

Kiv's mind simply couldn't grasp the immensity of the disaster. So he rejected it. He shook his head, partly in negation, partly to clear it.

"But that doesn't seem right," he said. "Edris powder will kill hugl. It's *always* killed them. For thousands of years. Why shouldn't it kill them now? What difference does their color make?"

The last glow of the Great Light

streamed through the window and outlined Jones' head. His face was coolly expressionless. "That's what you ought to find out, isn't it?"

"But... but, Jones—how do you know Edris powder won't kill them?"

"The same way you would have found out if you'd been here when the first ones appeared." The Earthman stopped, his oddly alien eyes looking at Kiv's own.

Kiv blinked and met the Earthman's glance, trying to penetrate the peculiar logic of Jones' thought processes.

"If I'd caught one, I'd have tried to dissect it, I suppose. Naturally, I'd have killed it first. But I'd have used the gas generator. I don't understand."

Jones smiled. "That's because I withheld a minor bit of information. The gas generator overheated several weeks ago and cracked."

Kiv smiled and nodded. "So you used Edris instead. And it didn't work?"

The Earthman frowned. "I would not say it didn't work altogether. The thing finally died, but it took a rather long time. Four days."

"Four days?" Kiv's voice held a touch of awe. The long shadows began to gather in the little laboratory room, and he reached for the illuminator cord. "Four days?" He paused, holding the cord, letting the implications of Jones' statement sink in.

There was a diffident knock on the door, and Narla stepped inside.

"I thought I'd find you here," she said. She looked around. "What are you two so somber about? Look." She held up a small printed booklet. "According to the Term Bulletin, I'm eligible to take Grandfather Syg's course— Application of Canon Law. Didn't you say you were going to take it, Kiv?"

"I wouldn't miss it for anything," Kiv said, glad to get his mind off the peculiarities of the black hugl for a moment.

"Grandfather Syg is a brilliant man," Jones said in his soft voice. "I believe McKay is working with him on teaching technique." Then, abruptly, he excused himself and left the lab.

Kiv turned to look again at the peacefully swimming hugl larvae. "I don't think I'll ever understand these Earthmen," he said.

"Nor will I," Narla agreed. "But you'll have to admit that the School has done some wonderful things for Nidor."

"Yes," said Kiv absently.

"Their new teaching techniques enable us to learn faster, and remember more. We can understand the Law and the Scriptures much better than any of our Ancestors did."

Kiv hardly heard her. He continued to stare at the larva tank. Then the meaning of her words reached him, and he saw that she was implying criticism of the Ancestors. And that, to him, was not far from sacrilege.

"Narla!" he said sharply.

"I'm sorry," she said quickly. "I didn't mean to say anything disrespectful. I guess I'll never understand."

And then he had to console her.

Before another day had passed, all the students of the Bel-rogas School had returned. The spacious green parks that surrounded the cluster of buildings were soon filled with young men and women, and a soft hum of conversation carried through the air.

The Bel-rogas School was comfortably secluded. When the Earthmen had founded the School, they had been emphatic in insisting that it be well removed from the Holy City of Gelusar.

"We would not want to build new buildings in so revered a place," the Earthman McKay had said. The Earthmen knew the Law and practiced it.

They had come to Nidor more than a generation earlier—come down from the sky in shining ships. And they had known the Law. They had been accepted by the Elders.

Their first step in getting their School functioning had been to set up rigid entrance examinations, both physical and mental, in order to pick the best students. They had insisted that it would be useless—a waste of time—to attempt to train people in the Law who did not have the mental capacity to learn it. The Law is for all, and yet only for a few.

The Earthmen did not teach the students, of course. That was left up

to the teaching priesthood. The Earthmen only showed the Grandfathers better methods for implanting knowledge in young minds.

The tests the Earthmen gave were incomprehensible, but they seemed to work all right. No one had ever failed a course at Bel-rogas, in sharp contrast to the other Schools, and its graduates were worthy of the highest positions in Nidorian society. Many had gone to the Temple to become priests, and it was expected that one day a graduate of Bel-rogas would be a member of the Council of Sixteen.

All in all, the great Lawyer and revered Ancestor, Bel-rogas Yorgen, should be well-pleased with the School that had been named in his honor.

But the conversations of the students vibrated with strange undertones, somehow. Several of them who came from the northern province of Sugon had not showed up at all. Rumor had it that they were fighting to save their parents' farms from the onslaught of the armies of hugl.

And Kiv didn't like it.

"There should be *something* we can do about it," he told Narla. "There must be some way of stopping them."

"Edris powder," said Narla. "Edris powder kills the hugl. Edris powder always has killed the hugl."

"But it's not killing them now," he said savagely, and sank back into his gloom. The new semester was

sliding by, and only one thing obsessed him: the failure of the Edris powder.

The Scripture prescribed Edris powder. Oh, not in so many words, but it did say, "Those ways are best which have been tried and pass the test."

Edris powder had passed the test. As long as there had been hugl, the Edris powder had controlled them.

But now the powder was failing. Could the test be passed once and then, failed, he wondered?

And, more important: could the Scripture be wrong? The thought sickened him.

The first three days of the new semester didn't even make an impression on him. He studied, but only half-heartedly, and what he learned left him as soon as classes ended. On the fourth day, eight of the young men asked permission to leave. They had received word that they were needed at home.

Within a week, the hugl problem had grown from a nuisance to the status of a full-fledged menace.

"You're not studying," Narla said, as he stared uneasily at the page of his textbook. "You're looking, but you're not studying. What's the matter?"

"Nothing," he said, and tried to focus his attention. But he couldn't study. He rubbed the palm of his hand over the light golden hair that blurred the outlines of his face, and shifted uneasily in his seat. He felt nervous without quite knowing what he was nervous about. The destruc-

tion of acres of crops, and even the occasional reports of lives being lost, bothered him, but there was something else gnawing at the back of his mind.

I'll look at it as if I'm an Earthman, he told himself. The Scripture says, rely on trusted things. The Scripture itself is a trusted thing. For thousands of years it has guided us safely. We are happy, contented with our world.

But what happens when the trusted guide no longer leads in the right direction? Kiv pretended for a moment that he was Jones, tried to look at the situation through his alien eyes.

When the trusted guide no longer leads, Jones might say—what?

Get a new guide?

He sat down to think it through—the whole thing, still using Jones' mind as a focus. And, when he came up with what he thought was a conclusion, he went somewhat timidly to Jones.

"I don't quite see what you mean, Kiv," the Earthman said, his eyes inscrutable. He leaned back on the comfortable chair in the tiny cubicle that was his office.

"Well, look here; we know that Edris powder is a nerve poison, right?"

Jones nodded wordlessly.

"Well, then, why doesn't it kill this new kind of hugl? I thought about it a long time, and I finally came up with an answer... at least, I think it's an answer," he said. He

looked at Jones for reassurance, and the Earthman somehow seemed to smile with his eyes.

"Edris kills through the epidermis of the animal; it doesn't bother them if they eat it," Kiv went on. "Now: if a nerve poison doesn't work, it's because it's not getting to the nerves. I checked my theory by measuring the thickness of the chitin armor of these black hugl, and I came up with something odd: the armor is half again as thick and considerably denser than the armor of the normal animal. The Edris takes longer to penetrate, and it takes more of it.

"How does that sound to you?"

Jones rubbed his smooth fingers through his chin hair. "It sounds perfectly logical to me. What about it?"

"Well, then, if we kill them when they're still in the larval stage, they won't have the protective armor. Edris can be put in the lakes and ponds in quantities great enough to kill the larval hugl without endangering any other aquatic life."

"Perhaps," Jones said cryptically.

"I'm sure of it," said Kiv, just a little surprised at his own new confidence. "I'd like to go to the Council of Elders in Gelusar. If they will send the word out over the wires in time, we can stop the hugl onslaught before it becomes really serious.

"If you would come with me to Gelusar, we could explain how this might work, and—" He stopped. He could suddenly read the expres-

sion on the Earthman's face, and he knew what it meant.

Jones confirmed it. "I'm sorry, Kiv. We are here only to teach, not to interfere in government policies. If you want to go to the Council, you have my permission to do so. In fact, you don't even need my permission."

Jones smiled. "It is said in the Scripture: 'You shall govern yourselves according to the Law.'" He accented the *yourselves*.

Kiv considered that for a moment. "All right," he said. "You've got me there. But it's not fair."

"The Scripture is a potent arguing force, Kiv. Don't ever forget that." The Earthman's pale-blue eyes looked steadily at him. "If you can understand and use the Scripture and the Law, you need fear nothing—neither here, nor in the sky."

"I... I see. Very well, Jones. If you think it is the right way, I shall go to the Council alone."

Kiv left the room without another word. His thoughts were confused, not angry. Somehow, the Earthmen always seemed to strike at the very root of a problem, no matter how complex. And they could back up their solutions with unerring references to the unanswerable Scripture.

Kiv turned his thoughts over in his mind as his deest trotted down the winding road to the Holy City.

He had brought his notebooks and his specimen drawings with

him; they would constitute his argument in favor of the new plan. He would have to be absolutely sure of what he was saying before he would be able to convince the all-powerful Council of Elders.

He had plenty of time. Because of the press of the emergency, it took four days to get an audience with the Elder of his Clan.

Kiv spent the four days wandering the city, trying not to think. Narla came down to join him on the second day, and they passed most of their time in the Grand Temple, staring at the huge lens through which the Great Light was focused.

Finally notification came through that Grandfather Bor peDrogh Brajjyd would see him.

Theoretically, any of the Elders of the Council of Sixteen would do, but in practice it was customary to call upon one's own Clan Elder. Thus, Kiv peGanz Brajjyd was obliged to seek audience with Elder Grandfather Bor peDrogh Brajjyd.

And Grandfather Bor peDrogh had been extremely busy for the past three days. On the fourth day, however, he consented to see Kiv, and because of the young man's status in the Bel-rogas School, the audience was for a full half hour.

A short, dark-skinned young acolyte, also of the Clan Brajjyd, ushered Kiv in. The Elder Grandfather's office was not ornate, but neither was it austere. It was decorated in simple good taste, with the customary symbol of the Great

Light in its honored niche in the wall.

The Elder Grandfather's venerable age was visible in every line of his body. The golden aura of body hair had long since turned to silver, and was growing sparse on his face, making him look oddly like the Earthmen. His face was lined but peaceful, and his hands, though gnarled with age, were still quick and graceful.

Kiv knelt and bowed his head.

"The peace of your Ancestors be with you always," said the priest. His voice was deeper and more virile than Kiv had expected.

"And may the Great Light illumine your mind as He does the world," Kiv responded.

"Sit down, my son," the old man said in his bass voice. "Tell me what it is that troubles you."

"It's the hugl, Grandfather. The farmers are having a terrible time controlling them, and I understand the situation has been getting worse for the past six days.

"That is correct, my son. Just what is it you wish to tell me?"

Kiv drew a deep breath. He looked at the Grandfather, who suddenly seemed terribly, terribly ancient. For a wild moment he thought of throwing himself at the old man's feet, begging forgiveness.

No. Pretend you are Jones, he told himself.

He realized he had been sitting silently while the Grandfather had awaited his reply with patience.

"I think I've found something

that might help, Grandfather. To wipe out the hugl, that is."

The shadow of a frown passed across the wrinkled face. "I see. Go on, my son." Still not a trace of impatience on the part of the Grandfather.

Kiv pulled his charts and drawings out of a leather carrying case.

"The trouble is that not very much is known about the hugl," he began. "Up to now, the Edris powder has controlled them well, so there was, of course, no reason to study them. But I did it as a sort of . . . well, as a sort of hobby, Grandfather. We call them 'projects' at the School; some little facet of life that we study in order to gain greater illumination in the Great Light's Law."

"Very interesting," said the old man. "I have heard that the Earthmen have ingenious ways of helping youngsters to learn. I think it's very commendable. And so you studied the hugl?"

"Yes, Grandfather. And I found out some rather weird things. You know those little teardrop-shaped things that you see swimming in ponds and lakes—the little animals that farmers call 'water wiggles'? Well, they are *young* hugl!"

"Young hugl?" The Grandfather frowned. "But they look nothing like hugl."

"I know, Grandfather," Kiv said. "That's the amazing thing. The young start out as little 'water



wiggles' and live that way for most of their lives—about a year. They eat soft water plants and decaying organic matter, since they have no teeth.

"After a year of this kind of life, they go down to the bottom and bury themselves in the mud, where they stay for thirty-five to forty days. During that time, they live in a sort of shell built out of mud. They absorb their endoskeletons and grow exoskeletons. When they emerge, they're hugl. The hugl," Kiv concluded triumphantly, "is the adult female form of the water-wiggle.

"As soon as it cracks out of its shell in the mud, the adult hugl goes to the surface and swims to land. As I said, the thing we call the hugl is the female; the male is a much

smaller animal, hardly more than an animated sex organ.

"The mating takes place on land, and the female immediately eats the male. Then she goes out and looks for more food—anything she can eat. And as long as she finds nothing to eat, she'll keep going looking for more—until she starves to death.

"If she does find food, she eats all she can hold, converting it into a kind of predigested concentrate. But her system can't assimilate anything she eats; her body just stores it.

"When she's eaten enough—when her glands tell her she's at the proper point, she crawls to a lake or pond, dies, and drops to the bottom.

"The eggs are never laid; they remain within the body of the female.

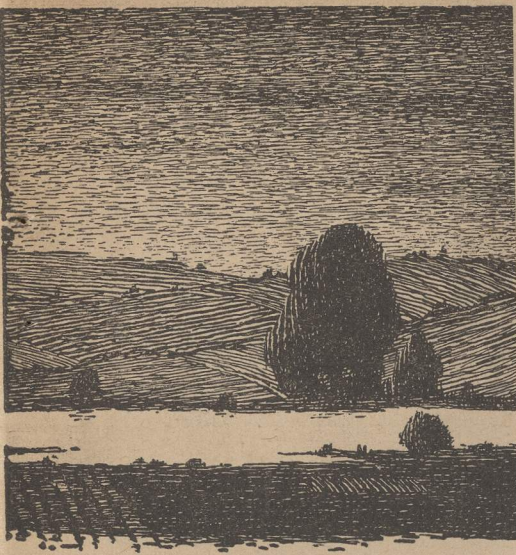

The dead female, protected from dissolution by her hard armor, provides food for the young larvae for the first few days of their life, until they're ready to go out and hunt for food of their own.

"Then the cycle begins all over again," Kiv concluded.

The old priest had looked carefully at Kiv's diagrams and listened to his lecture with interest. When Kiv finished, the Grandfather stood up and wandered to the window. He nodded slowly.

"Very interesting. Very! And what bearing does this have on our present crisis?"

"I'm coming to that, Grandfather," Kiv continued. "You see, the reason that Edris powder isn't working so well this time is simply that a new variety of hugl has ap-

peared which has an exoskeleton too heavy and dense to allow the Edris powder to penetrate very rapidly." He paused.

"But if we put the powder in the ponds, it will kill the young; their skins will absorb it immediately."

Kiv sat expectantly, while the old man returned to his desk, sat down, and began toying with a heavy, jewel-encrusted paperweight. Finally, the Grandfather said:

"A very interesting theory, and very ingeniously worked out. But I'm afraid it's not really of much practical use. As the Scripture says, 'Those ways are best which have been tried and passed the test.'"

I might have known that was coming, Kiv thought.

"You see," said the priest, "we have already alleviated the problem very simply. The farmers haven't been using enough Edris powder to cope with these hugl. Since the menace has been largely confined to the North so far, we have simply shipped additional quantities of Edris to the northern farmers. The hugl are dying."

"I see," Kiv said softly.

The Grandfather stood up in what could only be a gesture of dismissal. "I'm glad you told me all about the hugl, my son. Your instructors at the School must be fine ones. And now, I have another appointment. May the blessings of the Great Light beam down upon you and your children."

"...And, of course, he was

right," Kiv told Jones. "And I can understand why you wanted no part of it."

"You can, eh?" The Earthman's eyes were glittering oddly. "Kiv, have you thought about what is going to happen in another thirty days? The southern regions are closer to the pole, and cooler than the northern farms. The hugl take about thirty more days to mature down there; they haven't even begun to pupate yet. Between the two sections we have mostly arid mountains; the hugl aren't much of a menace there."

Jones paused and jabbed a forefinger at Kiv. "But if the Council diverts the southerner's supplies of Edris to the north, what's going to happen?" Jones demanded.

"I don't know," said Kiv, scratching his fuzzy head in puzzlement. "I really don't know."

Jones stood up and walked toward the door of Kiv's room. "Yes, you do," Jones said. "You're just afraid to say it out loud."

Kiv picked up a book and weighed it idly with one hand. As usual, Jones had cut right to the heart of the problem.

"All right. If things keep on like this, either the south or the north or both will be wiped clean of crops."

Jones nodded solemnly. "A fine situation, don't you think?"

Before Kiv could reply, the Earthman had walked through the door and was gone.

Classes continued as usual in Bel-

rogas, but over everything hung an invisible cloud of fear and uncertainty. Kiv found himself too preoccupied with the crisis to be able to devote much time to his studies, and he couldn't even bear the thought of working in his laboratory. The sight of hugl had become completely abhorrent to him.

And then the reports began to trickle down from the north.

The Edris powder, when used in large enough amounts, killed even the black hugl quite nicely. Unfortunately, it was also killing the crops.

Stalemate. Either let the hugl eat the crops or kill them before harvest time with an excess of Edris powder.

"In either case, people are going to go hungry," Kiv told Narla.

"I suppose they'll begin rationing soon."

Kiv didn't even bother to reply.

"Kiv?"

He turned to look up at Narla. Her face seems thin already, he thought. It's only my imagination, though.

"What is it," he asked wearily.

"Kiv, didn't the Grandfather want to listen at all when you went to him?"

"I told you. He listened very carefully. He just wasn't open to suggestions, that's all."

Kiv studied the golden-fuzzed backs of his hands, and said no more. The implications now were terrifying. The Grandfathers were

following the Scripture, and starvation was the consequence.

But the Great Light still streamed through the window.

"I'll go to Jones," he said. "Jones will help me."

Jones looked up quizzically when Kiv entered.

"I hope I didn't disturb your work," Kiv began apologetically.

Jones put him at ease immediately with a quick grin. "What's on your mind, Kiv?"

Kiv sat down in the chair facing Jones. He fumbled for an opening.

"The hugl?" Jones prompted.

"If they'd only accepted my plan!" Kiv broke out, almost bitterly. "Now what will they do?"

Jones leaned forward, and Kiv felt a sudden glow of confidence radiating from him. The thought struck him that the Earthmen must really be from the Great Light; in their quiet inconspicuous way, they had become the props on which the Nidorians could lean in time of trouble.

When the Earthmen had arrived, Kiv thought, they said they were here to guide us toward the Light. So my father Ganz told me. And it must be true.

"What will they do now?" Kiv repeated, wondering if Jones knew the answer. And Jones did.

"Kiv," said Jones softly, "you just didn't approach the Grandfather the right way. You didn't show him how the situation was according to the Law."

"How could I?" Kiv burst out. "There's nothing in the Law about this!"

Jones held up a hand. "You're still too impatient, Kiv. Listen to me. For one thing, you didn't tell him that you had watched the life cycle of the hugl with your own eyes. The Elder Grandfather probably thought you were just speculating. But the Scriptural passages would—"

Suddenly Kiv stood up. "I've got it! It was a passage that Narla quoted, from the Fourteenth Section: 'To destroy a thing, one must cut at the root, and not at the branch.'"

"Jones! I'm going back to Gelsusar!"

The dark-skinned little acolyte attempted to block Kiv as he burst into the vestibule of Elder Grandfather Bor peDrogh Brajjyd's office.

"You can't go in there like that!" the acolyte said.

"This is important," said Kiv.

"I say you can't go in there! The Elder Grandfather is not there, anyway."

"Where is he?"

"He's at a meeting of the Council," the acolyte said. "Not that that could possibly concern you."

Kiv didn't stay to argue. He dashed down the corridor and sped across the crowded street to the great dome of the Grand Temple. Then, almost unthinkingly, he plunged inside and found himself heading toward the High Council

room. The enormity of what he was doing did not strike him until he was inside the ornate room, facing the sixteen Elder Grandfathers as they sat in a majestic semi-circle.

They didn't even notice him for a while, so intent were they on their deliberations. Kiv's eyes passed from one to another.

There was the Elder of the Clan Sesom—Narla's clan. He recognized several of the other Clan Elders among the venerable assemblage. The very tall, gaunt man was Yorgen peYorgen Yorgen, a lineal descendant of the great Bel-rogas. Everyone knew him. And the somewhat plump Elder in crimson robes was Ganz peDrang Kovnish. And, of course, he recognized the Elder Brajjyd. The others, Kiv did not know.

Finally one of the elders noticed him.

"What are you doing here? Who are you?"

Kiv felt like turning and running. He held his ground, however, when he saw the Elder Brajjyd smiling at him.

"This man is of my Clan," the Elder Grandfather said in his prodigious bass rumble. "He spoke to me earlier; he has studied the hugl at the Bel-rogas."

At the mention of the School Kiv perceived a visible change in the Council's manner.

"He had some interesting information for me. But what is it you want now?" The Elder Grand-

father leaned forward as if to hear Kiv's reply more clearly.

Slowly, as if there were no one in the room but some other students at the School, he began to explain the life-cycle of the hugl to the Council as he had to the Elder Brajjyd earlier. They watched with seeming interest as Kiv spoke.

When he was finished, it was the Elder Kovnish who broke the silence.

"The Scripture says on this matter that—"

Had it been the fierce-looking Elder Yorgen who was speaking, Kiv would have never dared interrupt. But the chubby Elder Kovnish did not seem so terrifying to Kiv. He cut the Elder off in mid-sentence.

"Yes, the Scripture." He cited Narla's quotation: "'To destroy a thing, cut at the root, not at the branch.'"

"Fourteenth Section," the Elder Yorgen said in a sepulchral voice.

And then it seemed to Kiv that he was talking to the Elders as if they might be pupils of his. Heatedly he threw out his arms.

"Don't you see? The branch means the adult hugl; the root means the larva! It's right there in the Scripture: cut at the root of the menace! Pour Edris powder into the lakes; kill the larvae!"

The sixteen members of the Council stared coldly at Kiv for what seemed to him an infinitely long time. Then, as the meaning of what he had demonstrated broke through

to them, their stony silence turned to an excited hubbub.

"That's the last of it," said Nibro peGanz Korvish. The burly farmer crumpled the empty packet of Edris powder and let it fall to the ground. He turned to face Kiv, who stood watching him.

"Craziest thing I ever heard," Nibro peGanz said. "Dumping Edris into my lake. Might as well lie down and let the hugl eat me, too."

"Patience, friend," Kiv said. "The Council has decided."

"And therefore I accept," the farmer responded reluctantly.

"Right. I'll be back to check on your farm in six days." Kiv mounted his deest and trotted on down to the next farm.

The six days passed slowly, and then Kiv revisited the farms in the test areas.

The few hugl that had made their appearance didn't even constitute a swarm, much less a menace.

"It's all over," he said, throwing open the door of Jones' office with an assurance he had never known before. The Earthman was waiting inside, with Narla.

"What happened?" Narla asked anxiously.

"As expected," Kiv said. "Perfectly as expected. Hardly a hugl to be found."

Narla sighed in relief, and Jones' face creased in a broad smile.

"Congratulations," Jones said. "That makes you a celebrity, I sup-

pose. The Man Who Saved the World."

"It was your doing, Jones. You showed me how."

Jones shook his head. "Ah, no! It was *your* doing. I'm merely here as a guide. My aim is eventually to bring you and your people to the Great Light, Kiv. But actually I will only help you to bring yourselves. When you guide a deest, it is still the deest, not you, who is doing the real work."

Kiv frowned. "I don't care much for your analogy."

"Don't let him upset you," Narla said. "He's only teasing again." She drew close to him. "I'm tremendously proud of you," she said.

Jones rubbed his beard with a forefinger. "In a way, Kiv, I am, too. I can't help but think of how much you've learned since you came to Bel-rogas. You've really made progress."

"Do you think he should become a priest? And maybe someday become an Elder?" Narla asked.

"Why, I think they ought to put him on the Council right now," Jones replied. "After all, if he could walk right in there and tell the Council how to run Nidor—"

Jones paused and looked at Kiv, and Kiv met his glance with diffculty. There was something strange in the Earthman's blue eyes.

"Let's go outside," Kiv said. "The air in here's none too fresh." At the suggestion, Narla and Jones arose. The three of them filed out of Jones' office.

As they slowly proceeded down the stairs, Kiv considered what Jones had just said. *After all, if he could walk right in there and tell the Council how to run Nidor—*

But they were *Elders*, and he was only Kiv peGanz Brajyjd, an insignificant student. And he had told them what to do. And they had accepted it.

The thought suddenly cut into him. Since the beginning of time, young men had sat quietly and listened to the counsels of the Elders. Now, a bare thirty years after the Earthmen had descended from the sky, the age-old pattern had begun to break. Was this the way the Earthmen were leading them toward the Light? The enormity of what he had done struck him, and then the even greater enormity that no one had questioned his action. No one. The Earthmen were having their effects on Nidor, all right.

They reached the foot of the stairs.

Absently, he turned to enter the little room where his laboratory was. He opened the door and saw the rows and rows of cabinets, each with their specimens of hugl, and right in the center of the room was the larva tank.

"Where are you going, Kiv?" Jones called. "I thought you wanted some fresh air."

Jones started to walk out the front door, followed by Narla. Kiv hastened to catch up with them.

"What's on your mind, Kiv?" Jones asked as Kiv reached the door.

"Nothing, Jones, nothing." But he was certain the Earthman knew exactly what *was* on his mind.

He stepped out of the building onto the front lawn of the Belrogas campus. He looked up, and the Great Light illumined the cloud-laden sky. Suddenly he thought again of the quotation from the Fourteenth Section—and for some reason, his head began to hurt.

THE END

IN TIMES TO COME

The span of a human life seems long to a human being, of course... but there are some common processes going on around us that have a different time-scale. That could be most devastatingly unexpected, though, to human beings who think of the "eternal stars." Take a nice, stable G0 type sun, with some nice, stable planets. Establish a colony. Have it going in a nice, stable way for several generations. By this time, of course, they've had plenty of time to learn all about their world and its sun.

Oh... yes?

Murray Leinster, next issue, discusses the interesting—and devastating!—results of a minor, and almost unnoticeable variation in the output of a star. A minor, but Critical Difference...

THE EDITOR.

The Campbell version of the Hieronymous Machine, view from the rear showing arrangement of exploring electrode, prism, and eloptic shields between amplifier tubes. The bulk of the electrolytic condenser can shields the second stage from the detector output.

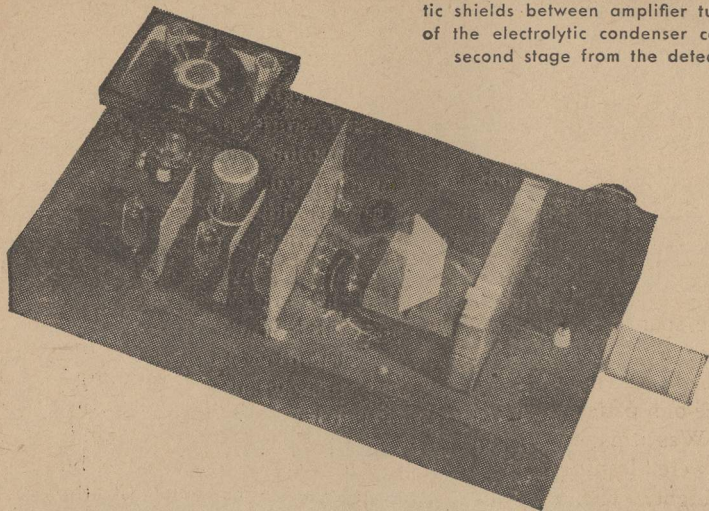

PSIONIC MACHINE — TYPE ONE

EDITOR'S NOTE: The following article is the first of several I hope to run. This is one I've written up myself, for two reasons:

1. Since you have voted "yes," the next question is what *form* of psionics articles should be run. This one represents the general form I believe is optimum, and will try to get. Now I need your specific comments on the *form* of the article—not merely the content, but the form.

2. In addition to giving you

readers a chance to comment on the article, it gives me an opportunity to have one psionic article to point to as "This is what I believe is needed," so that other writers can start working on articles with some general idea of the type of material I have in mind.

It appears to me that the ideal psionics article would be (a) written by someone *other than* the inventor or discoverer of the device or method discussed, and (b) someone who worked from *written* instructions,

(c) *without* direct personal contact with the inventor or discoverer, and, most important, (d) after having followed the written instructions, has, personally, obtained some result which appears a positive confirmation of the inventor-discoverer's claims.

Clearly, there are certain entirely reasonable objections to these stringent requirements. In this specific instance here, the Hieronymous machine, T. G. Hieronymous already has a United States Patent on his device. The patent constitutes the written instructions; I heard about the patent, sent for and obtained a copy, and was, therefore, able to get written instructions without personal contact with Mr. Hieronymous.

I followed the instructions in the patent, built the prescribed device, and tested it. I obtained positive results.

But—suppose Bill Blow, inventor, has just discovered a crude form of something that, he knows, is capable of immense development. If he gives written instructions to an unknown-to-him author of articles—he practically forfeits his right to a patent. As has been many, many times pointed out, authors of science-fiction stories describe only devices that are either (a) already patented, or (b) that they can't make. If they could make it, they'd patent it, if it were patentable.

The exception is, of course, the Law of Nature. Trouble is, any man who discovers a law of nature, while he can't patent that, can, usually, fig-

ure out some mighty handy applications of that Law of Nature. He has every reason to keep it a Trade Secret until such time as he can patent devices applying that newly discovered law. The fact that public orientation currently holds that a True Scientist works out discoveries for the Sheer Love of Truth is remarkably similar in content of idea to the not-so-antique idea that a True Artist worked for the Love of His Art—and shouldn't be paid for it.

Currently, we find that paying an author does nothing to depress his artistic tendencies, and seems, actually, to stimulate his creative abilities. Matter of fact, the only type that seems hurt by the offer of good, sound cash money for artistic productions is the would-be-but-never-could-be type. He lacks artistic ability, but the offer of money makes him try; it looks like easy money to him—money for no real work. (Hah! He should sweat that hard learning how, and then decide whether it's money for no work!) The would-be artists get hurt, because they are frustrated; there dangles the pay-check, but their reaching hands slide through it, as though it lay somehow in another dimension—visible, but unreachable.

Fact is, it does. And it is as near a psionic problem as any we can name! Some have the ability; some don't. And you can't define what it is.

Equally, some men today have the ability to discover laws of nature—and some don't. But the public orien-

tation is that the discoverer of a Law of Nature should freely publish his finding—just as the creator of a work of art, a few centuries ago, was expected, if he were *really* an *artist*, to give it to the world.

Personally, I see no reason why a doctor who has, by long, hard, and brilliant work, made a major discovery, should be expected to give it to the world. It makes no sense at all. If a brilliant researcher like Dr. Salk, for example, has succeeded in cracking one of Mankind's great problems—he should be paid for his work, and paid most handsomely. Reason: It's probable that a man who has made one great discovery, if

given adequate funds to carry out his researches, will make further valuable discoveries. It is also *probable* that he made his original discovery by attacking some problem in an *unorthodox* manner—in a way that competent authorities would not have approved of in advance. (If they had thought it was sound, said orthodox authorities would have done it themselves.) It is, therefore, predictable that Competent Authorities in the Field are inherently *incompetent* to determine where funds for research of an original and creative nature can best be applied.

If men who make major medical discoveries were paid for their work

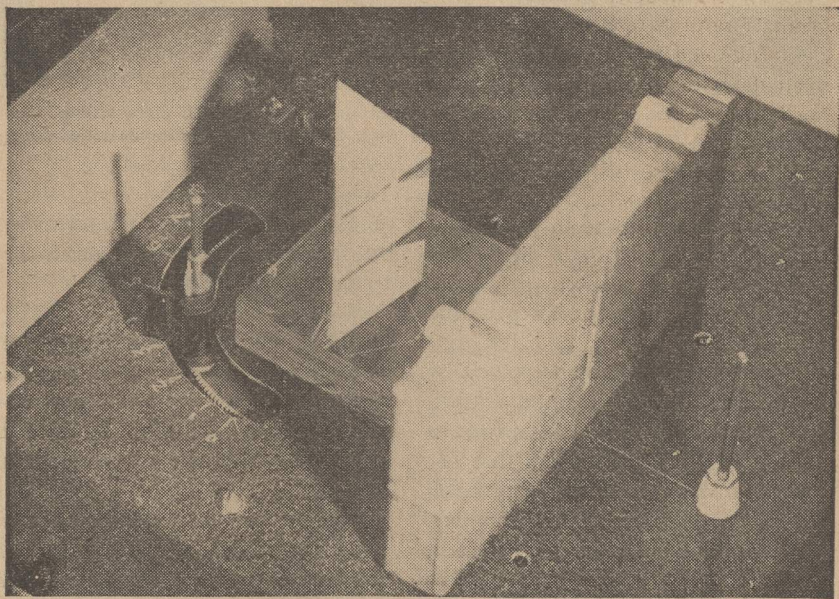

Radiating electrode at right; mycalex baffle with slit, prism, and exploring electrode at left. Tuning knob partly hidden behind prism. Prism is two identical war-surplus prisms cemented together.

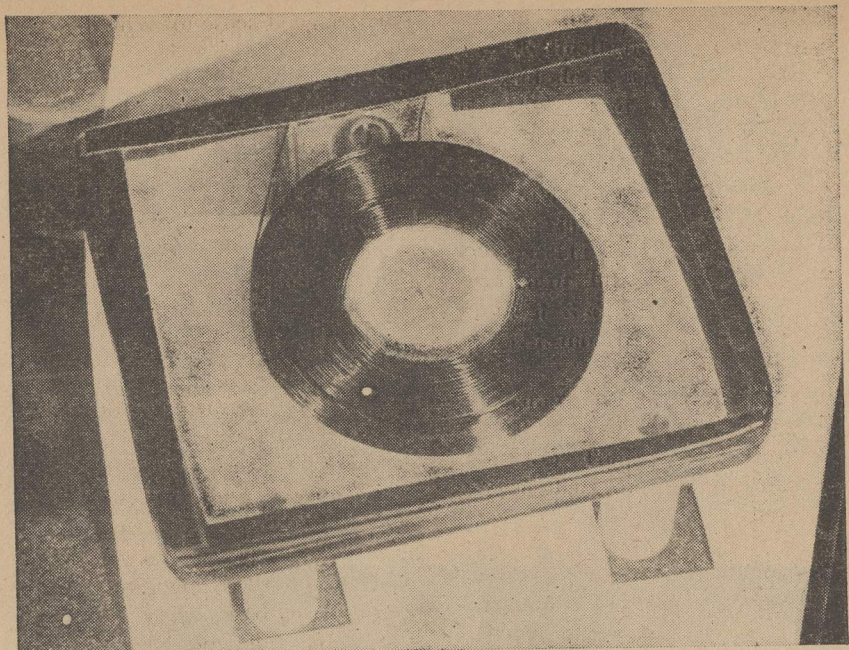

The detector device, with a sheet of white paper under it to make it more visible. Many various psionic machines appear to use one form or another of tactile detector device. The simplest and best known—Ouija board!

—if they were allowed to patent and thereby profit from their discoveries—we would, I suspect, get more high-value discoveries. It's probable that any long-known, and long-un-solved problem cannot be solved by application of any method known and accepted by orthodox competent authorities. And it's evident that any man who does crack such a problem has a gift for useful unorthodoxy. The human race would benefit mightily from encouraging him to try again *his own way*.

But Foundations and Institutes and Bureaus and Commissions can *not*

encourage him to try in his own way; they have to encourage research that *seems to them* to be sound.

All of which means that any man who has a psionic machine that works halfway is, with perfectly sound reason, going to be exceedingly skittish about revealing what he's got.

The purpose of these articles, however, is to induce workers to publish the halfway results that they—*and dozens of others already have*. If the psionic-machine inventor discovers that what he has is not new, but is

equally well-known to a score of others, then he might as well give up hope of patenting that idea. The net result of such publication would be to establish a common ground-work from which real progress could be made. In secrecy, vast labors will be expended covering the starting ground-work that a hundred others have, long since, covered. A man may work for twenty years getting the first steps . . . and then discover that hundreds of others have gone *that far*.

Hieronymous, for example, has a basic patent on certain aspects of psionic machines. I strongly suspect that dozens of other individuals have worked out approximately what Hieronymous has—and are guarding their secrets because they didn't, and couldn't, know that it was already known and patented.

The essential difficulty in getting the type of article we want lies in the fact that a man can get no profit, no reward in practical, live-on-able terms, for his efforts in making a fundamental discovery.

Very well; there may well be other patents of psionic machines I don't know of that will make possible articles which fulfill in full the desirable conditions. Otherwise, however—only a Grade A fool would allow another man to publish his unpatented work. And any man who thinks that the discoverer ought to allow such publication "for the good of Science" or "the sake of Truth" is an incompetent, thick-headed dreamer. Just because *he* has not

sufficient good sense to recognize the desirability of making a comfortable living in the world is no reason to insist others should be equally impractical.

Actually, the usual real motive behind insisting that the other fellow should reveal his device "for the sake of Truth" is simply "I want to have a chance at it, too!"

Well, the Universe gives every entity in it an equal chance; no man can keep you from making any discoveries you want to—provided they're discoveries in the Universe. But he does have a perfect right to keep you from using him as a convenient short-cut without paying for the privilege. Why should you get a free ride from the Known to the Unknown on his back, when you don't expect a free ride from New York to Calcutta on an air line?

There, then, is the great problem of getting fully definitive articles on psionic machines. Let's be honest enough to face the simple facts, and not demand that every researcher in the field be an utterly impractical foggy-headed dreamer.

If that's what you want—any Mystic will supply your demand. They'll reveal the whole secret to you, completely, and freely. All you have to do is listen to their freely-given explanations. If you can make any use of them, you're freely welcome.

If, on the other hand, you demand hard-headed, practical explanations—be prepared to respond with hard

practical cash. In old, and very cogent terms—put up, or shut up.

What people have appeared to want is a hard-headed, practical thinker, who is a dreamy-eyed idealist, willing to think a problem through in hard, realistic terms, and close-reasoned logic, while remaining so etherially impractical as to give his results away for free.

You can have it either way, but not both.

The most curious part of it all is this: if a man on a street corner starts passing out ten-dollar bills for free, everybody ducks. We don't trust someone who gives away something valuable for no discernible reason. Then why, I wonder, do people expect the greatest values of all to be given freely?

THE HIERONYMOUS MACHINE

The device is covered by U. S. Patent No. 2,482,773.

The patent is, of course, in very general language, which is intended to be adequate instruction for anyone "skilled in the art." Probably it is; the difficulty is that Hieronymus describes in it his discovery of *eloptic* radiation; the device he has patented is a mechanism applying eloptic radiation to the detection and analysis of minerals. Since this is an original patent in the field of eloptic radiation, I know of no one but Hieronymus who is "skilled in the art." In consequence, following the instruc-

tions leaves problems that aren't too easy to solve.

First, in constructing the machine it was necessary to use the fundamental proposition of the true scientific method: If you are going to study an hypothesis—accept it wholeheartedly, and follow through on it without quibbling. To build an Hieronymous machine, we must accept the existence of eloptic radiation as a working hypothesis, whether we believe it utter nonsense or not. You have a perfect right to reserve conviction; you do not have a right to reserve action on the logical consequences of the hypothesis while claiming to make a test of it.

Hieronymus states that eloptic radiations are emitted by all elements continuously; that these radiations can be manipulated either as electric currents, or as optical phenomena, interchangeably. That the radiations can be picked up in electrical circuits, passed through lenses and prisms, and amplified electrically. The device discussed applies these principles.

My private opinion is that the theory is invalid.

My direct observation is that his machine works, but *not* by application of any known physical principle. I believe Hieronymus has discovered and applied a new principle, but not the one he names in his theory.

The device described is supposed to permit analysis of a mineral, by study of the eloptic radiations of that mineral. Since I was interested solely in a yes-no answer as to whether

there was, or was not an effect of the general nature described, I did not build it quite as the patent specified; I left out an attenuator mechanism whereby the strength of the signals can be measured to determine the relative quantities of different elements present in the sample.

Broadly, in the drawing of Fig. 1, a sample to be tested is placed in the field of a coil, L_1 , which is tuned by Condenser C_1 . The radiation picked up by this circuit is conducted to a fixed electrode E_1 , which radiates the optic radiation in its optical phase.

The radiation falls on the slit in the "opaque insulating material" B, and some passes through to the glass

prism. There it is differentially refracted, the eoptic radiation from different elements being refracted differently. The second electrode, E_2 , is movable, and is used to explore the output radiation from the prism. The radiation picked up by E_2 is conducted to the input of a three-stage broad-band amplifier, and amplified. The output of the amplifier feeds the detector.

There were problems. What frequency range should the coil and condenser tune to? Not specified. Since the three stage broad-band amplifier was specified in such terms as to indicate it operated in or near the broadcast radio range of frequencies,

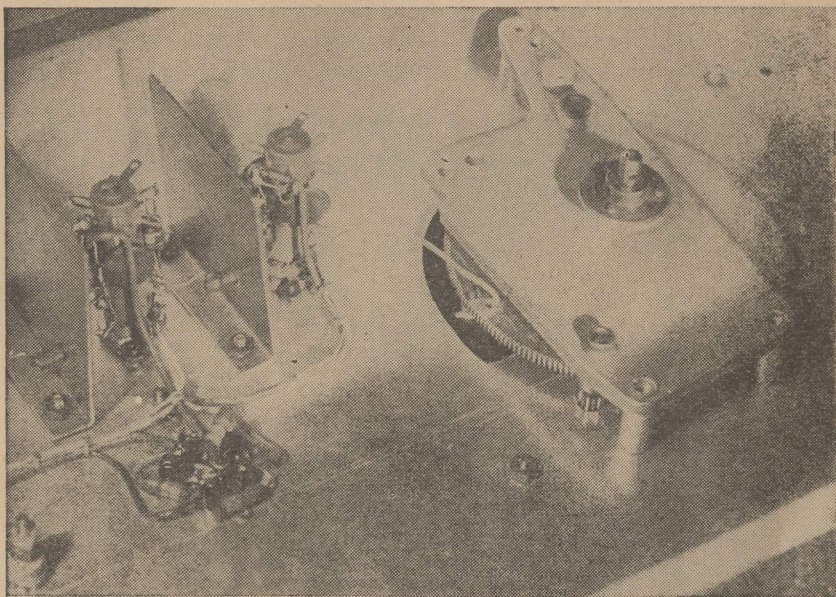

War surplus supplied the gearing on which the exploring electrode is mounted. Under chassis view shows eoptic radiation shielding between stages, with miniature ceramic feed-thru condenser coupling.

I made L_1-C_1 resonate in that region. (In operation, it seemed to have little or no effect, so perhaps I had the wrong range.)

The "opaque insulating material" at B presented a problem, too. Opaque to what? Insulating in what terms? Hard rubber is an "opaque insulating material" in ordinary terms . . . but happens to be lucidly transparent to infra red, and because of extremely poor dielectric properties, a resistive load to high-frequency radio currents. Glass is an excellent insulator, and lead glass is opaque to everything above the visual spectrum—ultraviolet and way out in the X-ray region. Oxygen and ozone are exceedingly good insulators, and opaque to UV.

I used "mucalex" insulating material. This is a synthetic material formed by mixing mica chips and dust in a binder of low-melting lead glass; it's an excellent insulating material, and is opaque by multiple-scattering refraction from far down in the infrared to far in the ultraviolet. From there on, the lead glass makes it opaque into the Xray region.

But that doesn't say a thing about what it is to eloptic radiation. A mechanical engineer of 1830 could state with absolute conviction that it would be utterly impossible to send power through a solid metal shaft bent in three right angles, with no gearing. But I'll undertake to send more power than that engineer ever dreamed of through a six-inch thick solid copper shaft bent in three right

angles—and please leave out the gears; they make for poor contact.

It may well be easy for one "skilled in the art" to follow the directions—but there's going to be a lot of guesswork until someone defines terms in new ways, with new precision, to fit the new art.

Hieronymous did specify a glass prism; that was easy. I used a war-surplus item I picked up; I suspect it was intended as an optical range-finder prism. It was a standard 45° prism.

The movable electrode E_2 I made of a piece of one-eighth inch thick copper rod; it's mounted on a ceramic insulator, which in turn is mounted on an 8"-diameter gear. (Part of the tuning mechanism from a war-surplus radio transmitter. It's aluminum, about one-quarter inch thick.) A smaller gear with a standard radio tuning knob drives it; the electrode is free to move through a 90° arc.

The amplifier is a conventional three-stage impedance-coupled RF amplifier, using three 6AU6 pentodes. The circuit diagram is shown in Fig. 2.

However, since eloptic radiation can radiate as well as travel on wires, the three stages should be shielded from each other both electrically and optically, to avoid feedback oscillation. The resistors and coupling RF chokes were mounted on Vector turret sockets, and metal plates erected both above and below the chassis to shield each circuit unit from the next. The .001 coupling condensers

were fitted through one-quarter inch holes in the shielding plates.

The detector Hieronymous specifies makes no sense either in terms of the eloptic radiation theory, or in terms of standard physics. It is because of the detector that I cannot accept the eloptic radiation theory readily.

The detector was described in the Hieronymous patent; as I made it, it consists of two 4 x 5 inch plates of $\frac{1}{4}$ " thick polystyrene plastic. A 1" diameter piece of cardboard (from an empty candy box) was saturated with polystyrene plastic cement, and the two polystyrene plates clamped

on it, forming a sandwich. When the cement had thoroughly set, about forty turns of #22 enameled copper wire were wound in a flat spiral around the cardboard disk, between the plates. The whole was cemented to three $1\frac{1}{2}$ " long sections of $\frac{1}{2}$ " polystyrene rod, to support it off the chassis.

The output of the third 6AU6 was capacity coupled by a .001 mF ceramic condenser to one end of the spiral coil, and the other end of the coil was grounded to chassis.

Preliminary tests with oscilloscope and test generator showed that the amplifier was not unstable—no oscillation—but amplified well. A healthy

Testing the machine. A gold coin-bracelet resting on the empty box is the test material. With a given test substance, different individuals find response at the same setting; with different test substances, the individual finds response at different settings.

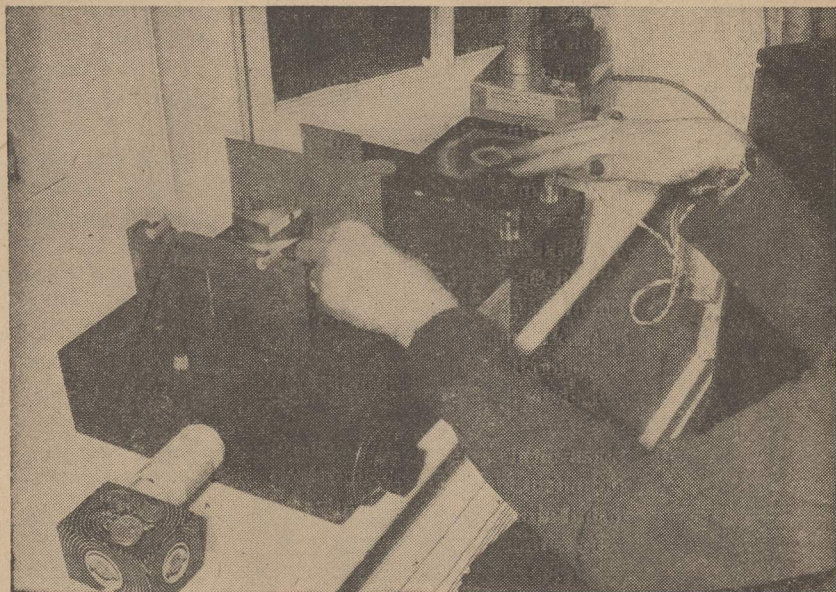

500 Kc signal could be developed across the spiral coil, readily picked up with an exploring coil hitched to a vacuum tube voltmeter.

Since a 6AU6 is a miniature, voltage-amplifier pentode, it cannot develop power enough to produce detectable radio-frequency heating in human fingers.

Polystyrene is an exceedingly good insulating material; there can be no detectable leakage through a 1/4-inch thickness of flawless plastic. (The tables suggest it would be adequate insulation for 50,000 volts.)

Bench tests indicate, in other words, that it was a perfectly good three-stage amplifier, but that there was no input, and no output.

A piece of pig lead was put in front of the pickup coil, and the plastic plate of the detector stroked with the fingers, as Hieronymous instructed. According to his patent, when the exploring electrode was properly aligned, the detector plate would feel "tacky" to the fingers.

I didn't like what I got. So I called in my ten-year-old daughter. She was aware that Daddy had been, as usual, building something at the electronics bench. This meant nothing to her; radio and electronics being my hobby, there's usually some

sort of electronics project under way. Hi-fi amplifiers, oscilloscopes, photo-multiplier light meters—something. My daughters are not unaccustomed to being asked to wiggle dials, push buttons, or watch meters at one end of the shop while I adjust something at the other end.

This, then, was for her simply another one of Daddy's somewhat boring gadgets, which she was being asked to help adjust. Stroking a plastic plate is no more outré than watching the dancing patterns of an oscilloscope. So . . .

"You tune it like a radio, by turning this knob, and you stroke this plastic gimmick here. Tune it till the plastic feels different."

"Feels different? What do you mean? Different how?"

"Hm-m-m . . . well, that's for you to tell me. Maybe it'll feel furry, like a kitten, all of a sudden, or maybe it will feel as though it turned into a bowl, instead of being flat. But you tune it and tell me."

Presently she stopped, tuned back, and said, "It feels like . . . sort of like tar. If I pushed on it, my fingers would get stuck."

So I called in my fifteen-year-old daughter, gave her similar misdirected instructions, and got the report

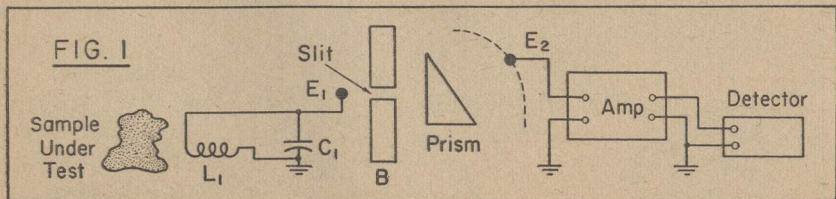
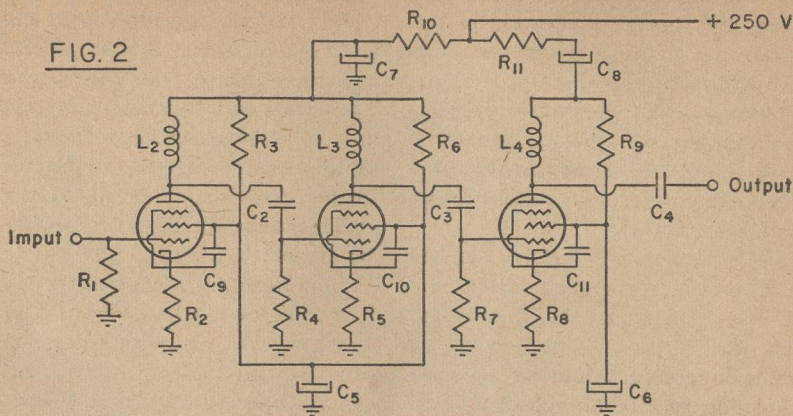

FIG. 2



- $R_{1r}, R_{4r}, R_{7r} \dots 15,000 \text{ ohm, } \frac{1}{4} \text{ watt}$
 $R_{2r}, R_{5r}, R_{8r} \dots 100 \text{ ohm, } \frac{1}{2} \text{ watt}$
 $R_{3r}, R_{6r}, R_{9r} \dots 40,000 \text{ ohm, } \frac{1}{2} \text{ watt}$
 $R_{10r}, R_{11r} \dots 1000 \text{ ohm, } \frac{1}{2} \text{ watt}$
 $L_{2r}, L_{3r}, L_{4r} \dots 2.5 \text{ millihenry RF choke. (Millen subminiature type)}$
 $C_{2r}, C_{3r}, C_{4r} \dots .001 \text{ uF miniature ceramic}$
 $C_{9r}, C_{10r}, C_{11r} \dots .01 \text{ uF ceramic}$
 $C_{5r}, C_{6r}, C_{7r}, C_{8r} \dots 10 \text{ uF, four-section 300 volt electrolytic}$

that it "feels as though—oh, sort of like it had orange juice spilled on it."

The thing is, trying to describe a tactile sensation is extremely difficult. And this isn't any ordinary sensation; it's been described by a highly trained adult as "rather like thick grease—slippery, yet sticky."

Try describing the difference between the flavor of a peach and a banana some time.

Sight and sound happen to be the only two sensory systems we've done even a moderate job of calibrating and analyzing in English. We can say a peach *looks* rounder, and has a more orange color. Well, the flavor

of a peach is more thornish and less gornal than that of a banana.

The Hieronymous detector produces a tactile sensation as its output.

Of the first dozen people who tried the device, nine got reaction, varying from "weak but definite" to one young woman who was decidedly scared by having her fingers become, seemingly, almost immovably stuck to the plate.

Of the three who got no reaction, one appears to have been distinctly afraid of "electrical things"; the highly visible coil of electric wire, only a 1/4-inch from her fingers, bothered her excessively. (The fact that the polystyrene plastic could

have blocked a voltage three hundred times that actually present in the chassis has nothing whatever to do with the matter.)

I tested the output when operators were getting strong reactions from the detector; neither oscilloscope nor vacuum tube voltmeter detected anything whatever.

Hieronymous detector detects something that isn't detectable by any standard form of meter—yet something that is output from a standard 6AU6 vacuum tube, with a 2.5 mH RFC load, working into a standard .001 mF ceramic condenser and a standard flat spiral coil of ordinary copper wire.

Hieronymous says that the eloptic radiation minerals emit can be caught by a photographic plate—that the detector will react to a *photograph* of a mineral specimen as it would to the mineral itself.

This I have not tested. I was checking to see if the machine itself did anything out of the ordinary.

It does.

I am personally aware that it does, because I built it, in my own shop, from written instructions, without any acquaintance with the inventor. The components are perfectly standard, commercial units, with the exception of the detector device. And I *know* there's no jiggery-poker, because I did the whole construction job myself.

Hieronymous has something—but I don't know what, and I doubt very strongly that he knows, either. I think his theory is wrong, because it has no bearing on the behavior of the detector, which is the critical unit of the whole system.

Mr. Hieronymous has stated that individuals wishing to build the device for their own private experimental use have his permission to do so, but inasmuch as this is a patented device no commercial use or manufacture of the device is permissible without consultation with Mr. Heironymous.

JOHN W. CAMPBELL, JR.

THE END

THE ANALYTICAL LABORATORY

(Continued from page 72)

MARCH 1956 ISSUE

PLACE	STORY	AUTHOR	POINTS
1.	Double Star (Pt. 2)	Robert A. Heinlein	1.23
2.	Exploration Team	Murray Leinster	2.07
3.	Minor Ingredient	Eric Frank Russell	3.21
4.	A Nice Little Niche	Herbert L. Cooper	3.85
5.	Man in the Sky	Algis Budrys	4.35

THE EDITOR.

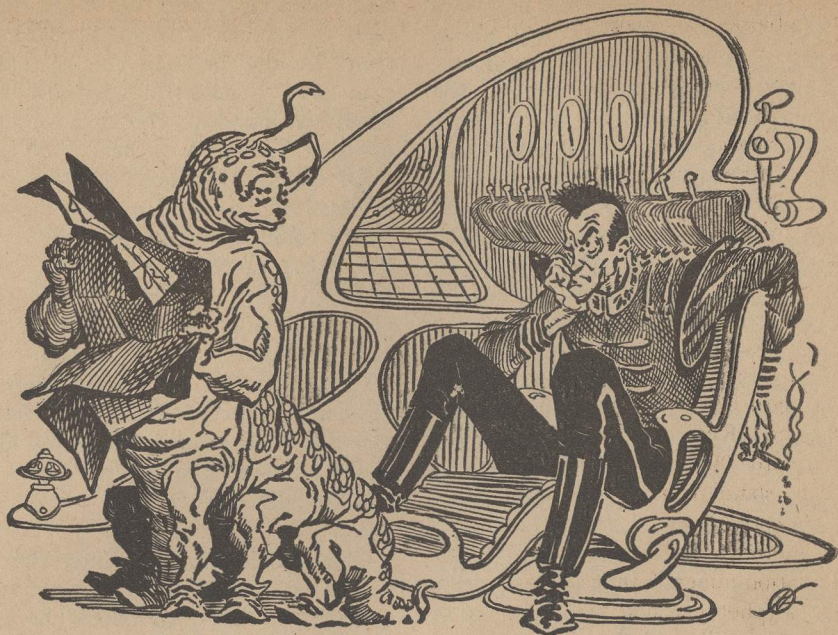

THE LIVE COWARD

The Patrol was bound by its rule of absolutely non-lethal measures—which meant, of course, that very fancy dishonesty, unfair tactics, and skulduggery became absolutely imperative!

BY POUL ANDERSON

Illustrated by Freas

The fugitive ship was pursued for ten light-years. Then, snapping in and out of subspace drive with a reckless disregard of nearby suns and tracer-blocking dust clouds, it shook the Patrol cruiser.

The search that followed was not so frantic as the danger might seem to warrant. Haste would have done no good; there are a million planetary systems affiliated with the League, and their territory includes

several million more too backward for membership. Even a small planet is such a wilderness of mountains, valleys, plains, forests, oceans, ice-fields, cities, and loneliness—much of it often quite unexplored—that it was hopeless to ransack them meter by meter for a single man. The Patrol knew that Varris' boat had a range of three hundred parsecs, and in the course of months and man-years of investigation it was pretty well established that he had not refueled at any registered depot. But a sphere two thousand light-years across can hold a lot of stars.

The Patrol offered a substantial reward for information leading to the arrest of Samel Varris, human, from the planet Caldor (No. so-and-so in the Pilots' Manual), wanted for the crime of inciting to war. It circulated its appeal as widely as possible. It warned all agents to keep an eye or a feeler or a telepathic organ out for a man potentially still capable of exploding a billion living entities into radioactive gas. Then it waited.

A year went by.

Captain Jakor Thymal of the trading ship *Ganash*, operating out of Sireen in the primitive Spiral Cluster area, brought the news. He had seen Varris, even spoken to the fellow. There was no doubt of it. Only one hitch: Varris had taken refuge with the king of Thunsba, a barbarous state in the southern hemisphere of a world known to the Galactics—such few as had ever heard of it—as Ryfin's Planet. He

had gotten citizenship and taken the oath of service as a royal guardsman. Loyalty between master and man was a powerful element in Thunsban morality. The king would not give up Varris without a fight.

Of course, axes and arrows were of small use against flamers. Perhaps Varris could not be taken alive, but the Patrol could kill him without whiffing very many Thunsbans. Captain Thymal settled complacently back to wait for official confirmation of his report and the blood money. Nothing ever occurred to him but that the elimination of Varris would be the simplest of routine operations.

Like hell!

Wing Alak eased his flitter close to the planet. It hung in cloudy splendor against a curtain of hard, needle-sharp spatial stars, the Cluster sky. He sat gloomily listening to the click and mutter of instruments as Drogs checked surface conditions.

"Quite terrestroid," said the Galmathian. His antennae lifted in puzzlement above the round, snouted face and the small black eyes. "Why did you bother testing? It's listed in the Manual."

"I have a nasty suspicious mind," said Alak. "Also an unhappy one." He was a thin, medium-tall human with the very white skin that often goes with flaming red hair. His Patrol uniform was as dandified as regulations allowed.

Drogs hitched three meters of green, eight-legged body across the cabin. His burly arms reached out

to pick up the maps in three-fingered hands. "Yes . . . here's the Thunsba kingdom and the capital city . . . what's it called? . . . Wainabog. I suppose our quarry is still there; Thymal swore he didn't alarm him." He sighed. "Now I have to spend an hour at the telescope and identify which place is what. And you can sit like my wife on an egg thinking beautiful thoughts!"

"The only beautiful concept I have right now is that all of a sudden the Prime Directive was repealed."

"No chance of that, I'm afraid . . . not till a less bloodthirsty race than yours gets the leadership of the League."

"Less? You mean more, don't you? 'Under no circumstances whatsoever may the Patrol or any unit thereof kill any intelligent being.' If you do—" Alak made a rather horrible gesture. "Is that bloodthirsty?"

"Quite. Only a race with as gory a past as the Terrans would go to such extremes of reaction. And only as naturally ferocious a species could think of making such a commandment the Patrol's great top secret . . . and bluffing with threats of planet-wide slaughter, or using any kind of chicanery to achieve its ends. Now a Galmathian will run down a farstak in his native woods and jump on its back and make a nice lunch while it's still running . . . but he wouldn't be able to imagine cold-bloodedly sterilizing an entire world, so he doesn't have to ban himself

from honest killing even in self-defense." Drog's caterpillar body hunched itself over the telescope.

"Get thee behind me, Satan . . . and don't push!" Alak returned murkily to his thoughts. His brain was hypnotically stuffed with all the information three generations of traders had gathered about Thunsba. None of it looked hopeful.

The king was—well, if not an absolute monarch, pretty close to being one, simply because the law had set him over the commons. Like many warlike barbarians, the Thunsbans had a quasi-religious reverence for the letter of the law, if not always for its spirit. The Patrol had run head-on into two items of the code: (a) the king would not yield up a loyal guardsman to an enemy, but would fight to the death instead; (b) if the king fought, so would the whole male population, unmoved by threats to themselves or their mates and cubs. Death before dishonor! Their religion, which they seemed quite fervent about, promised a roisterous heaven to all who fell in a good cause, and a suitably gruesome hell for oathbreakers.

Hm-m-m . . . there was a powerful ecclesiastical organization, and piety had not stopped a good deal of conflict between church and throne. Maybe he could work through the priesthood somehow.

The outworld traders who came to swap various manufactured articles for the furs and spices of Ryfin's

Planet had not influenced the local cultures much. Perhaps they had inspired a few wars and heresies, but on the whole the autochthones were content to live in the ways of their fathers. The main effect of trading had been a loss of superstitious awe—the strangers were mighty, but they were known to be mortal. Alak doubted that even the whole Patrol fleet could bullyrag them into yielding on so touchy a point as Varris' surrender.

"What I can't understand," said Drogs, "is why we don't just swoop down and give the city a blanket of sleep-gas." This mission had been ordered in such tearing haste that he had been given only the most nominal briefing; and on the way here, he had followed his racial practice of somnolence—his body could actually "store" many days' worth of sleep.

His free hand gestured around the flitter. It was not a large boat, but it was well equipped, not only with weapons—for bluffing—but with its own machine shop and laboratory.

"Metabolic difference," said Alak. "Every anaesthetic known to us is poisonous to them, and their own knockout chemicals would kill Varris. Stun beams are just as bad—supersonics will scramble a Ryfinian's brain like an egg. I imagine Varris picked this world for a bolt-hole just on that account."

"But he didn't know we wouldn't simply come down and shoot up the den."

"He could make a pretty shrewd

guess. It's a secret that we never kill, but no secret that we're reluctant to hurt innocent bystanders." Alak scowled. "There are still a hundred million people on Caldon who'd rise—bloodily—against the new government if he came back to them. Whether he succeeded or not, it'd be a genocidal affair and a big loss of face to the Patrol."

"Hm-m-m . . . he can't get far from this world without more fuel; his tanks must be nearly dry. So why don't we blockade this planet and make sure he never has a chance to buy fuel?"

"Blockades aren't that reliable," said Alak. Drogs had never been involved in naval operations, only in surface work. "We could destroy his own boat easily enough, but word that he's alive is bound to leak back to Caldon now. There'd be attempt after attempt to run the blockade and get him out. Sooner or later, one would succeed. We're badly handicapped by not being allowed to shoot to hit. No, damn it, we've got to lift him, and fast!"

His eyes traveled wistfully to the biochemical shelves. There was a potent drug included, a nembutal derivative, hypnite. A small intramuscular injection could knock Varris out; he would awaken into a confused, passive state and remain thus for hours, following any lead he was given. Much useful information about his conspiracy could be extracted. Later, this drug and other techniques would be used to rehabilitate his twisted psyche, but that

was a job for the specialists at Main Base.

Alak felt more handcuffed than ever before in his pragmatist life. The blaster at his waist could incinerate a squad of Thunsban knights — but their anachronistic weapons weren't so ridiculous when he wasn't allowed to use the blaster.

"Hurry it up," he said on a harsh note. "Let's get moving—and don't ask me where!"

A landing field had been made for the traders just outside the walls of Wainabog. Those bulked thick and gray, studded with turrets and men-at-arms, over a blue landscape of rolling fields and distant hills. Here and there Alak saw thatched-roofed hamlets; two kilometers from the town was a smaller community, also fortified, a single great tower in its middle crowned with a golden X. It must be the place mentioned in the trader narratives. Grimmoch Abbey, was that the name?

It was not too bad a mistranslation to speak of abbeys, monks, knights, and kings. Culturally and technologically, Thunsba was fairly close to medieval Europe.

Several peasants and townfolk stood gaping at the flitter as Alak emerged. Others were on their way. He swept his gaze around the field and saw another spaceboat some distance off—must be Varris', yes, he remembered the description now. A dozen liveried halberdiers guarded it.

Carefully ignoring the drab-clad commons, Alak waited for the offi-

cial greeters. Those came out in a rattle of plate armor, mounted on yellow-furred animals with horns and shoulder humps. A band of crossbowmen trotted in their wake and a herald wearing a scarlet robe blew his trumpet in their van. They pulled up with streaming banners and thunderous hoofs; lances dipped courteously, but eyes had a watchful stare behind the snouted visors of their helmets.

The herald rode forth and looked down at Alak, who was clad in his brightest dress uniform. "Greeting to you, stranger, from our lord Morlach, King of all Thunsba and Defender of the West. Our lord Morlach bids you come sup and sleep with him." The herald drew a sword and extended it hilt first. Alak ran hastily through his lessons and rubbed his forehead against the handle.

They were quite humanoid on Ryfin's Planet—disturbingly so, if you hadn't seen as many species as Alak. It was not the pale-blue skin or the violet hair or the short tails which made the difference: always, in a case like this, the effect was of a subtler wrongness. Noses a shade too long, faces a trifle too square, knees and elbows held at a peculiar angle—they looked like cartoon figures brought to life. And they had a scent of their own, a sharp mustardy odor. Alak didn't mind, knowing full well that he looked and smelled as odd to them, but he had seen young recruits get weird neuroses after a few months on a

planet of "humanoids to six points of classification."

He replied gravely in the Thunbsan tongue: "My lord Morlach has my thanks and duty. I hight Wing Alak, and am not a trader but an envoy of the traders' king, sent hither on a mission most delicate. I pray the right to see my lord Morlach as soon as he grant."

There was more ceremony, and a number of slaves were fetched to carry Alak's impressive burden of gifts. Then he was offered a mount, but declined—the traders had warned him of this little joke, where you put an outworlder on a beast that goes frantic at alien smells. With proper haughtiness he demanded a sedan chair, which was an uncomfortable and seasick thing to ride but had more dignity. The knights of Wainabog enclosed him and he was borne through the gates and the cobbled avenues to the fortresslike palace.

Inside, he did not find the rude splendor he had expected, but a more subtle magnificence, really beautiful furnishings. Thunbsa might throw its garbage out in the streets, but had excellent artistic taste. There were a hundred nobles in the royal audience chamber, a rainbow of robes, moving about and talking with boisterous gestures. Servants scurried around offering trays of food and liquor. A small orchestra was playing: the saw-toothed music hurt Alak's ears. A number of monks, in gray robes and with hoods

across their faces, stood unspeaking along the walls, near the motionless men-at-arms.

Alak advanced under gleaming pikes and knelt before the king. Morlach was burly, middle-aged, and long-bearded, wearing a coronet and holding a naked sword on his lap. At his left, the place of honor—most of this species were left-handed—sat an older "man," clean-shaven, hook-nosed, bleak-faced, in yellow robe and a tall bejeweled hat marked with a golden X.

"My duty to you, puissant lord Morlach. Far have I, unworthy Wing Alak of Terra, come to behold your majesty, before whom the nations tremble. From my king unto you, I bear a message and these poor gifts."

The poor gifts made quite a heap, all the way from clothes and ornaments of lustrous synthetic to flashlights and swords of manganese steel. Ryfin's Planet couldn't legally be given modern tools and weapons—not at their present social stage of war and feudalism—but there was no ban on lesser conveniences which they couldn't reproduce anyhow.

"Well met, Sir Wing Alak. Come, be seated at my right." Morlach's voice rose, and the buzzing voices, already lowered in curiosity, stopped at once. "Be it known to all men, Sir Wing Alak is in truth my guest, most holy and inviolable, and all injuries to him, save in lawful duel, are harms to me and my house which the Allshaper bids me avenge."

The nobles crowded closer. It was

not a very formal court, as such things go. One of them came to the front as Alak mounted the high seat. The Patrolman felt a tingle along his back and a primitive stirring in his scalp.

Samel Varris.

The refugee war lord was dressed like the other aristocrats, a gaudy robe of puffed and slashed velvet, hung with ropes of jewels. Alak guessed correctly that a royal guardsman ranked very high indeed, possessing his own lands and retinue. Varris was a big dark man with arrogant features and shrewd eyes. Recognition kindled in him, and he strode forward and made an ironic bow.

"Ah, Sir Wing Alak," he said in Thunsban. "I had not awaited the honor of your calling on me yourself."

King Morlach huffed and laid a ringed hand on his sword. "I knew not you twain were acquainted."

Alak covered an empty feeling with his smoothest manner. "Yes, my lord, Varris and I have jousted erenow. Indeed, my mission hither concerns him."

"Came you to fetch him away?" It was a snarl, and the nobility of Wainabog reached for their daggers.

"I know not what he has told you, my lord—"

"He came hither because foemen had overwhelmed his own kingdom and sought his life. Noble gifts did he bring me, not least of them one of the flame-weapons your folk are so niggardly with, and he gave wise

redes by which we hurled back the armies of Rachanstog and wrung tribute out of their ruler." Morlach glared from lowered brows. "Know then, Sir Wing Alak, that though you are my guest and I may not harm you, Sir Varris has taken oaths as my guardsman and served right loyally. For this I have given him gold and a broad fief. The honor of my house is sacred . . . if you demand he be returned to his foes, I must ask that you leave at once and when next we meet it shall be the worse for you!"

Alak pursed his lips to whistle, but thought better of it. Handing out a blaster—! It was unimportant in itself, the firearm would be useless once its charge was spent, but as a measure of Varris' contempt for Galactic law—

"My lord," he said hastily, "I cannot deny I had such a request. But it was never the intent of my king or myself to insult your majesty. The request will not be made of you."

"Let there be peace," said the high priest on Morlach's left. His tone was not as unctuous as the words: here was a fighter, in his own way, more intelligent and more dangerous than the brawling warriors around him. "In the name of the Allshaper, we are met in fellowship. Let not black thoughts give to the Evil an entering wedge."

Morlach swore.

"In truth, my lord, I bear this envoy no ill will," smiled Varris. "I vouch that he is knightly, and wishes

but to serve his king as well as I seek to serve yourself. If my holy lord abbot"—the title was nearly equivalent—"calls peace on this hall, then I for one will abide by it."

"Yes . . . a sniveling shavechin to whine peace when treachery rises," growled Morlach. "You have enough good lands which should be mine, Abbot Gulmanan—keep your greasy fingers off my soul, at least!"

"What my lord says to me is of no consequence," answered the cleric thinly. "But if he speaks against the Temple, he blasphemes the Allshaper."

"Hell freeze you, I'm a pious man!" roared Morlach. "I make the sacrifices—for the Allshaper, though, not for his fat-gutted Temple that would push me off my own throne!"

Gulmanan flushed purple, but checked himself, bit narrow lips together and made a bridge of his

bony fingers. "This is not the time or place to question where the ghostly and the worldly authorities have their proper bounds," he said. "I shall sacrifice for your soul, my lord, and pray you be led out of error."

Morlach snorted and called for a beaker of wine. Alak sat inconspicuously till the king's temper had abated. Then he began to speak of increased trade possibilities.

He had not the slightest power to make treaties, but he wanted to be sure he wasn't kicked out of Wainabog yet.

Heavily dosed with anti-allergen, Alak was able to eat enough of the king's food to cement his status as guest. But Drog brought him a case of iron rations when the Galmathian came to attend his "master" in the assigned palace apartment.

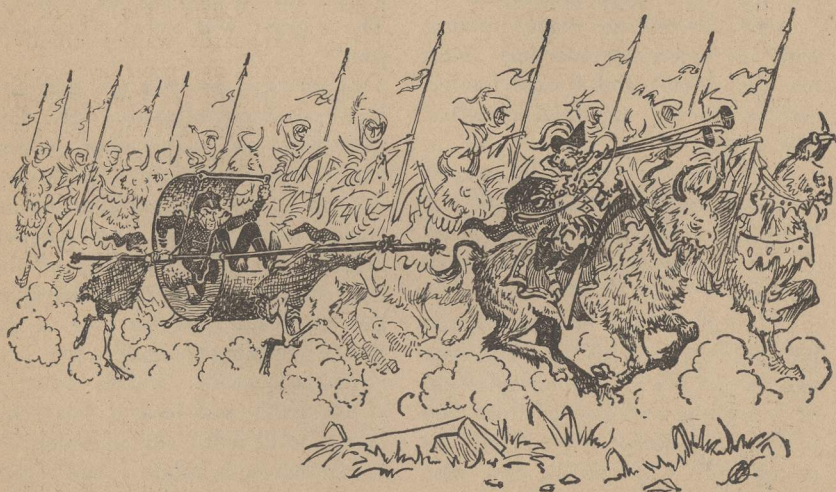

The human sat moodily by the window, looking out at the glorious night sky of clotted stars and two moons. There was a fragrant garden beneath him, under the bleak castle walls. Somewhere a drunken band of nobles was singing—he had left the feast early and it was still carousing on. A few candles lit the tapestried dankness of the room; they were perfumed, but not being a Ryfinnian he did not enjoy the odor of mercaptan.

"If we got several thousand husky Patrolmen," he said, "and put them in armor, and equipped them with clubs, we might slug our way in and out of this place. Right now I can't think of anything else."

"Well, why don't we?" Drogs hunched over a burbling water pipe, cheerfully immune to worry.

"It lacks finesse. Nor is it guaranteed—these Thunsbans are pretty hefty too, they might overpower our men. If we used tanks or something to make ourselves invincible, it'd be just our luck to have some gallant fathead of a knight get squashed under the treads. Finally, with the trouble at Sannanton going on, the Patrol can't spare so large a force—and by the time they can, it might well be too late. Those unprintable traders must have told half the League that Varris has been found. We can look for a rescue attempt from Caldon within a week."

"Hm-m-m . . . according to your account, the local church is at loggerheads with the king. Maybe it can be persuaded to do our work

for us. Nothing in the Prime Directive forbids letting entities murder each other."

"No—I'm afraid the Temple priests are only allowed to fight in self-defense, and these people never break a law." Alak rubbed his chin. "You may have the germ of an idea there, though. I'll have to—"

The gong outside the door was struck. Drogs humped across the floor and opened.

Varris came in, at the head of half a dozen warriors. Their drawn blades gleamed against flickering shadow.

Alak's blaster snaked out. Varris grinned and lifted his hand. "Don't be so impetuous," he advised. "These boys are only precautionary. I just wanted to talk."

Alak took out a cigarette and puffed it into lighting. "Go on, then," he invited tonelessly.

"I'd like to point out a few things, that's all." Varris was speaking Terran; the guards waited stolidly, not understanding, their eyes restless. "I wanted to say I'm a patient man, but there's a limit to how much persecution I'll stand for."

"Persecution! Who ordered the massacres at New Venus?"

Fanaticism smoldered in Varris' eyes, but he answered quietly: "I was the legitimately chosen dictator. Under Caldonian law, I was within my rights. It was the Patrol which engineered the revolution. It's the Patrol which now maintains a hated colonialism over my planet."

"Yes—until such time as those

hellhounds you call people have had a little sense beaten into them. If you hadn't been stopped, there'd be more than one totally dead world by now." Alak's smile was wintry. "You'll comprehend that for yourself, once we've normalized your psyche."

"You can't cleanly execute a man." Varris paced tiger-fashion. "You have to take and twist him till everything that was holy to him has become evil and everything he despised is good. I'll not let that happen to me."

"You're stuck here," said Alak. "I know your boat is almost out of fuel. Incidentally, in case you get ideas, mine is quite thoroughly boobytrapped. All I need do is holler for reinforcements. Why not surrender now and save me the trouble?"

Varris grinned. "Nice try, friend, but I'm not that stupid. If the Patrol could have sent more than you to arrest me, it would have done so. I'm staying here and gambling that a rescue party from Caldon will arrive before your ships get around to it. The odds are in my favor."

His finger stabbed out. "Look here! By choice, I'd have my men cut you down where you stand—you and that slimy little monster. I can't, because I have to live up to the local code of honor; they'd throw me out if I broke the least of their silly laws. But I can maintain a large enough bodyguard to prevent you from kidnaping me, as you've doubtless thought of doing."

"I had given the matter some small consideration," nodded Alak.

"There's one other thing I can do, too. I can fight a duel with you. A duel to the death—they haven't any other kind."

"Well, I'm a pretty good shot."

"They won't allow modern weapons. The challenged party has the choice, but it's got to be swords or axes or bows or—something provided for in their law." Varris laughed. "I've spent a lot of time this past year, practicing with just such arms. And I went in for fencing at home. How much training have you had?"

Alak shrugged. Not being even faintly a romantic, he had never taken much interest in archaic sports.

"I'm good at thinking up nasty tricks," he said. "Suppose I chose to fight you with clubs, only I had a switchblade concealed in mine."

"I've seen that kind of thing pulled," said Varris calmly. "Poison is illegal, but gimmicks of the kind you mention are accepted. However, the weapons must be identical. You'd have to get me with your switchblade the first try—and I don't think you could—or I'd see what was going on and do the same. I assure you, the prospect doesn't frighten me at all."

"I'll give you a few days here to see how hopeless your problem is. If you turn your flutter's guns on the city, or on me . . . well, I have guns, too. If you aren't out of the kingdom in a week—or if you begin

to act suspiciously before that time—
—I'll duel you."

"I'm a peaceable man," said Alak. "It takes two to make a duel."

"Not here, it doesn't. If I insult you before witnesses, and you don't challenge me, you lose knightly rank and are whipped out of the country. It's a long walk to the border, with a bull whip lashing you all the way. You wouldn't make it alive."

"All right," sighed Alak. "What do you want of me?"

"I want to be let alone."

"So do the people you were going to make war on last year."

"Good night." Varris turned and went out the door. His men followed him.

Alak stood for a while in silence. Beyond the walls, he could hear the night wind of Ryfn's Planet. Somehow, it was a foreign wind, it had another sound from the rushing air of Terra. Blowing through different trees, across an unearthly land—

"Have you any plan at all?" murmured Drogs.

"I had one." Alak clasped nervous hands behind his back. "He doesn't *know* I won't bushwhack him, or summon a force of gunners, or something lethal like that. I was figuring on a bluff—but it seems he has called me. He wants to be sure of taking at least one Patrolman to hell with him."

"You could study the local *code duello*," suggested Drogs. "You could let him kill you in a way which looked like a technical foul.

Then the king would boot him out and I could arrest him with the help of a stun beam."

"Thanks," said Alak. "Your devotion to duty is really touching."

"I remember a Terran proverb," said Drogs. Galmathian humor can be quite heavy at times. "The craven dies a thousand deaths, the hero dies but once."

"Yeh. But you see, I'm a craven from way back. I much prefer a thousand synthetic deaths to one genuine case. As far as I'm concerned, the live coward has it all over the dead hero—" Alak stopped. His jaw fell down and then snapped up again. He flopped into a chair and cocked his feet up on the windowsill and ran a hand through his ruddy hair.

Drogs returned to the water pipe and smoked imperturbably. He knew the signs. If the Patrol may not kill, it is allowed to do anything else—and sublimated murder can be most fascinatingly fiendish.

In spite of his claims to ambassadorial rank, Alak found himself rating low—his only retinue was one ugly nonhumanoid. But that could be useful. With their faintly contemptuous indifference, the nobles of Wainabog didn't care where he was.

He went, the next afternoon, to Grimmoch Abbey.

An audience with Gulmanan was quickly granted. Alak crossed a paved courtyard, strolled by a temple where the hooded monks were hold-

ing an oddly impressive service, and entered a room in the great central tower. It was a large room, furnished with austere design but lavish materials, gold and silver and gems and brocades. One wall was covered by bookshelves, illuminated folios, many of them secular. The abbot sat stiffly on a carved throne of rare woods. Alak made the required prostration and was invited to sit down.

The old eyes were thoughtful, watching him. "What brought you here, my cub?"

"I am a stranger, holy one," said the human. "I understand little of your faith, and considered it shame that I did not know more."

"We have not yet brought any outworlder to the Way," said the abbot gravely. "Except, of course, Sir Varris, and I am afraid his devotions smack more of expediency than conviction."

"Let me at least hear what you believe," asked the Patrolman with all the earnestness he could summon in daylight.

Gulmanan smiled, creasing his gaunt blue face. "I have a suspicion that you are not merely seeking the Way," he replied. "Belike there is some more temporal question in your mind."

"Well—" They exchanged grins. You couldn't run a corporation as big as this abbey without considerable hard-headedness.

Nevertheless, Alak persisted in his queries. It took an hour to learn what he wanted to know.

Thunbsa was monotheistic. The theology was subtle and complex, the ritual emotionally satisfying, the commandments flexible enough to accommodate ordinary fleshly weaknesses. Nobody doubted the essential truth of the religion; but its Temple was another matter.

As in medieval Europe, the church was a powerful organization, international, the guardian of learning and the gradual civilizer of a barbarous race. It had no secular clergy—every priest was a monk of some degree, inhabiting a large or small monastery. Each of these was ruled by one officer—Gulmanan in this case—responsible to the central Council in Augnchar city; but distances being great and communications slow, this supreme authority was mostly background.

The clergy were celibate and utterly divorced from the civil regime, with their own laws and courts and punishments. Each detail of their lives, down to dress and diet, was minutely prescribed by an unbreakable code—there were no special dispensations. Entering the church, if you were approved, was only a matter of taking vows; getting out was not so easy, requiring a Council decree. A monk owned nothing; any property he might have had before entering reverted to his heirs, any marriage he might have made was automatically annulled. Even Gulmanan could not call the clothes he wore or the lands he ruled his own: it all belonged to the corporation, the abbey. And the abbey was rich;

for centuries, titled Thunsbans had given it land or money.

Naturally, there was conflict between church and king. Both sought power, both claimed overlapping prerogatives, both insisted that theirs was the final authority. Some kings had had abbots murdered or imprisoned, some had gone weakly to Canossa. Morlach was in-between, snarling at the Temple but not quite daring to lay violent hands on it.

"... I see." Alak bowed his head. "Thank you, holy one."

"I trust your questions are all answered?" The voice was dry.

"Well, now . . . there are some matters of business—" Alak sat for a moment, weighing the other. Gulmanan seemed thoroughly honest; a direct bribe would only be an insult. But honesty is more malleable than one might think—

"Yes? Speak without fear, my cub. No words of yours shall pass these walls."

Alak plunged into it: "As you know, my task is to remove Sir Varris to his own realm for punishment of many evil deeds."

"He has claimed his cause was righteous," said Gulmanan noncommittally.

"And so he believes. But in the name of that cause, he was prepared to slay more folk than dwell on this entire world."

"I wondered about that—"

Alak drew a long breath and then spoke fast. "The Temple is eternal, is it not? Of course. Then it must

look centuries ahead. It must not let one man, whose merits are doubtful at best, stand in the way of an advancement which could mean saving thousands of souls."

"I am old," said Gulmanan in a parched tone. "My life has not been as cloistered as I might have wished. If you are proposing that you and I could work together to mutual advantage, say so."

Alak made a sketchy explanation. "And the lands would be yours," he finished.

"Also the trouble, my cub," said the abbot. "We already have enough clashes with King Morlach."

"This would not be a serious one. The law would be on our side."

"Nevertheless, the honor of the Temple may not be compromised."

"In plain words, you want more than I've offered."

"Yes," said Gulmanan bluntly.

Alak waited. Sweat studded his body. What could he do if an impossible demand was made?

The seamed blue face grew wistful. "Your race knows much," said the abbot. "Our peasants wear out their lives, struggling against a miserly soil and seasonal insect hordes. Are there ways to better their lot?"

"Is that all? Certainly there are. Helping folk progress when they wish to is one of our chief policies. My . . . my king would be only too glad to lend you some technicians—farmwrights?—and show you how."

"Also . . . it is pure greed on my part. But sometimes at night, look-

ing up at the stars, trying to understand what the traders have said—that this broad fair world of ours is but a mote spinning through vastness beyond comprehension—it has been an anguish in me that I do not know how that is.” Now it was Gulmanan who leaned forward and shivered. “Would it be possible to . . . to translate a few of your books on this science astronomic into Thunshan?”

Alak regarded himself as a case-hardened cynic. In the line of duty, he had often and cheerfully broken the most solemn oaths with an audible snap. But this was one promise he meant to keep though the sky fell down.

On the way back, he stopped at his flitter, where Drogs was hiding from a gape-mouthed citizenry, and put the Galmathian to work in the machine shop.

A human simply could not eat very much of this planet’s food; he would die in agony. Varris had taken care to have a food-synthesizer aboard his boat, and ate well that night of special dishes. He did not invite Alak to join him, and the Patrolman munched gloomily on what his service imagined to be an adequate, nutritious diet.

After supper, the nobles repaired to a central hall, with a fireplace at either end waging hopeless war on the evening chill, for serious drinking. Alak, ignored by most, sauntered through the crowd till he got to Varris. The fugitive was conversing

with several barons; from his throne, King Morlach listened interestedly. Varris was increasing his prestige by explaining some principles of games theory which ought to guarantee success in the next war.

“. . . And thus, my gentles, it is not that one must seek a certain victory, for there is no certainty in battle, but must so distribute his forces as to have the greatest *likelihood* of winning—”

“Hogwash!” snapped Alak. The Thunshan phrase he used was more pungent.

Varris raised his brows. “Said you something?” he asked.

“I did.” Alak slouched forward, wearing his most insolent expression. “I said it is nonsense you speak.”

“You disagree, then, sir?” inquired a native.

“Not exactly,” said the Patrolman. “It is not worth disagreeing with so lunkheaded a swine as this base-born Varris.”

His prey remained impassive. There was no tone in the voice: “I trust you will retract your statement, sir.”

“Yes, perhaps I should,” agreed Alak. “It was too mild. Actually, of course, as is obvious from a single glance at his bloated face, Sir Varris is a muckeating sack of lip-wagging flatulence whose habits, I will not even try to describe since they would make a barnyard blush.”

Silence hit the hall. The flames roared up the chimneys. King Morlach scowled and breathed heavily, but could not legally interfere. The

warriors dropped hands to their knives.

"What's your purpose?" muttered Varris in Terran.

"Naturally," said Alak in Thunsban, "if Sir Varris does not dispute my assertions, there is no argument."

The Caldonian sighed. "I will dispute them on your body tomorrow morning," he answered.

Alak's foxy face broke into a delighted grin. "Do I understand that I am being challenged?" he asked.

"You do, sir. I invite you to a duel."

"Very well." Alak looked around. Every eye in the place was welded to him. "My lords, you bear witness that I have been summoned to fight Sir Varris. If I mistake me not, the choice of weapons and ground is mine."

"Within the laws of single combat," rumbled Morlach venomously. "None of your outworld sorceries."

"Indeed not." Alak bowed. "I choose to fight with my own swords,

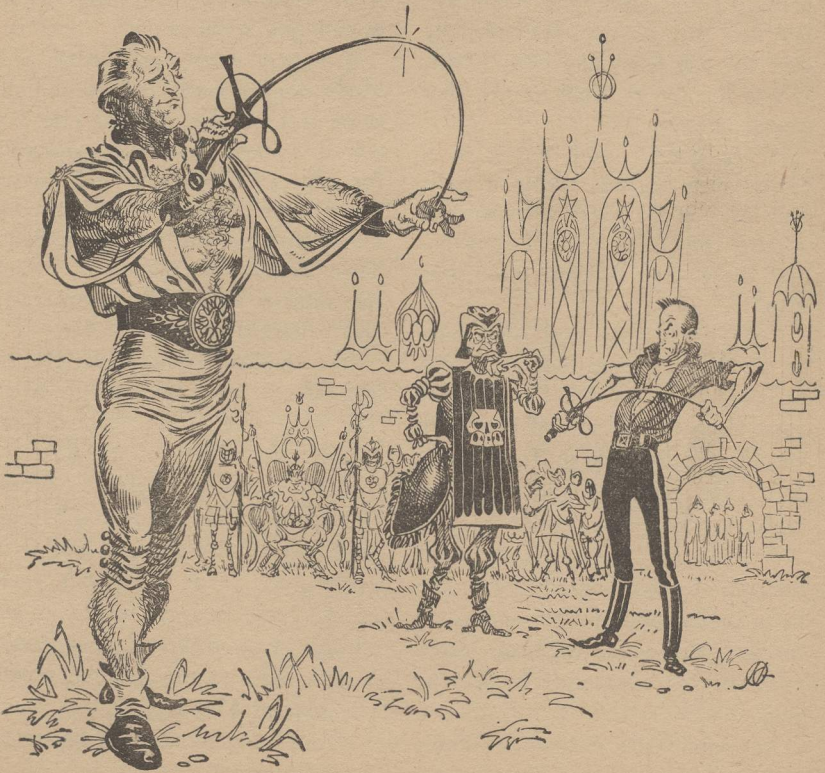

which are lighter than your claymores but, I assure you, quite deadly if one does not wear armor. Sir Varris may, of course, have first choice of the pair. The duel will take place just outside the main gate of Grimmoch Abbey."

There was nothing unusual about that. A badly wounded contestant could be taken in to the monks, who were also the local surgeons. In such a case, he was allowed to recover, after which a return engagement was fought. In the simple and logical belief that enmities should not be permitted to fester, the Thunsban law said that no duel was officially over till one party had been killed. It was the use of light swords that caused interest.

"Very good," said Varris in a frosty voice. He was taking it well; only Alak could guess what worries—*what trap is being set?*—lay behind those eyes. "At dawn tomorrow, then."

"Absolutely not," said Alak firmly. He never got up before noon if he could help it. "Am I to lose my good sleep on account of you? We will meet at the time of Third Sacrifice." He bowed grandly. "Good night, my lord and gentles."

Back in his apartment, he went through the window and, with the help of his small antigrav unit, over the wall and out to his boat. Varris might try to assassinate him as he slept.

Or would the Caldonian simply rely on being a better swordsman?

Alak knew that was the case. This might be his last night alive.

A midafternoon sun threw long streamers of light across blue turf and the walls of Grimmoch Abbey. There was a hundred-meter square cleared before the gate; beyond that, a crowd of lords and ladies stood talking, drinking, and betting on the outcome. King Morlach watched ominously from a portable throne—he would not thank the man who did away with the useful Sir Varris. Just inside the gateway, Abbot Gulmanan and a dozen monks waited like stone saints.

Trumpets blew, and Alak and Varris stepped forth. Both wore light shirts and trousers, nothing else. An official frisked them ceremoniously for concealed weapons and armor. The noble appointed Master of Death trod out and recited the code. Then he took a cushion on which the rapiers were laid, tested each, and extended them to Varris.

The outlaw smiled humorlessly and selected one. Alak got the other. The Master of Death directed them to opposite corners of the field.

Alak's blade felt light and supple in his fingers. His vision and hearing were unnaturally clear, it was as if every grass blade stood out sharp before him. Perhaps his brain was storing data while it still could. Varris, one hundred forty meters off, loomed like a giant.

"And now, let the Allshaper defend the right!"

Another trumpet flourish. The duel was on.

Varris walked out, not hurrying. Alak went to meet him. They crossed blades and stood for a moment, eyes thrusting at eyes.

"Why are you doing this?" asked the refugee in Terran. "If you have some idiotic hope of killing me, you might as well forget it. I was a fencing champion at home."

"These shivs are gimmicked," said Alak with a rather forced grin. "I'll let you figure out how."

"I suppose you know the penalty for using poison is burning at the stake—" For a moment, there was a querulous whine in the voice. "Why can't you leave me alone? What business was it ever of yours?"

"Keeping the peace is my business," said Alak. "That's what I get paid for, anyhow."

Varris snarled. His blade whipped out. Alak parried just in time. There was a thin steel ringing in the air.

Varris danced gracefully, aggressively, a cold intent on his face. Alak made wild slashes, handling his rapier like a broadsword. Contempt crossed Varris' mouth. He parried a blow, riposted, and Alak felt pain sting his shoulder. The crowd whooped.

Just one cut! Just one cut before she gets me through the heart! Alak felt his chest grow warm and wet. A flesh wound, no more. He remembered that he'd forgotten to thumb the concealed button in his hilt, and did so with a curse.

Varris' weapon was a blur before his eyes. He felt another light stab. Varris was playing with him! Coldly, he retreated, to the jeers of the audience, while he rallied his wits.

The thing to do . . . what the devil did you call it, riposte, slash, *en avant*? Varris came close as Alak halted. The Patrolman thrust for his left arm. Varris blocked that one. Somehow, Alak slewed his blade around and pinked the outlaw in the chest.

Now—God help me, I have to survive the next few seconds! The enemy steel lunged for his throat. He slapped it down, clumsily, in bare time. His thigh was furrowed. Varris sprang back to get room. Alak did the same.

Watching, he saw the Caldonian's eyes begin helplessly rolling. The rapier wavered. Alak, deciding he had to make this look good, ran up and skewered Varris in the biceps—a harmless cut, but it bled with satisfactory enthusiasm. Varris dropped his sword and tottered. Alak got out of the way just as the big body fell.

The nobles were screaming. King Morlach roared. The Master of Death rushed out to shove Alak aside. "It is not lawful to smite a fallen man," he said.

"I . . . assure you . . . no such intention—" Alak sat down and let the planet revolve around him.

Abbot Gulmanan and the monks stooped over Varris, examining with skilled fingers. Presently the old priest looked up and said in a low

voice that somehow cut through the noise: "He is not badly hurt. He should be quite well tomorrow. Perhaps he simply fainted."

"At a few scratches like that?" bawled Morlach. "Master, check that red-haired infidel's blade! I suspect poison!"

Alak pressed the retracting button and handed over his sword. While it was being inspected, Varris was borne inside the abbey and its gate closed on him. The Master of Death looked at both weapons, bowed to the king, and said puzzledly:

"There is no sign of poison, my lord. And after all, Sir Varris had first choice of glaives . . . and these two are identical, as far as I can see . . . and did not the holy one say he is not really injured?"

Alak swayed erect. "Jussa better man, tha's all," he mumbled. "I won fair an' square. Lemme go get m' hurts dressed—I'll see y' all in the morning—"

He made it to his boat, and Drogs had a bottle of Scotch ready.

It took will power to be at the palace when the court convened—not that Alak was especially weakened, but the Thunsbans started their day at a hideous hour. In this case, early rising was necessary, because he didn't know when the climax of his plot would be on him.

He got a mixed welcome, on the one hand respect for having overcome the great Sir Varris—at least in the first round—on the other hand, a certain doubt as to whether

he had done it fairly. King Morlach gave him a surly greeting, but not openly hostile; he must be waiting for the doctors' verdict.

Alak found a congenial earl and spent his time swapping dirty jokes. It is always astonishing how many of the classics are to be found among all mammalian species. This is less an argument for a prehistoric Galactic Empire than for the parallelism of great minds.

Shortly before noon, Abbot Gulmanan entered. Several hooded monks followed him, bearing weapons—most unusual—and surrounding one who was unarmed. The priest lifted his hand to the king, and the room grew very quiet.

"Well," snapped Morlach, "what brings you hither?"

"I thought it best to report personally on the outcome of the duel, my lord," said Gulmanan. "It was . . . surprising."

"Mean you Sir Varris is dead?" Morlach's eyes flared. He could not fight his own guest, but it would be easy enough to have one of his guardsmen insult Wing Alak.

"No, my lord. He is in good health, his wounds are negligible. But—somehow the grace of the All-shaper fell on him." The abbot made a pious gesture; as he saw Alak, one eyelid drooped.

"What mean you?" Morlach dithered and clutched his sword.

"Only this. As he regained consciousness, I offered him ghostly counsel, as I always do to hurt men. I spoke of the virtues of the Temple,

of sanctity, of the dedicated life. Half in jest, I mentioned the possibility that he might wish to renounce this evil world and enter the Temple as a brother. My lord, you can imagine my astonishment when he agreed . . . nay, he insisted on deeding all his lands and treasure to the abbey and taking the vows at once." Gulmanan rolled his eyes heavenward. "Indeed, a miracle!"

"*What?*" It was a shriek from the king.

The monk who was under guard suddenly tore off his hood. Varris' face glared out. "Help!" he croaked. "Help, my lord! I've been betrayed—"

"There are a dozen brothers who witnessed your acts and will swear to them by the mightiest oaths," said the abbot sternly. "Be still, Brother Varris. If the Evil has reentered your soul, I shall have to set you heavy penances."

"Witchcraft!" It whispered terribly down the long hall.

"All men know that witchcraft has no power inside the walls of a scared abbey," warned Gulmanan. "Speak no heresies."

Varris looked wildly about at the spears and axes that ringed him in. "I was drugged, my lord," he gasped. "I remember what I did, yes, but I had no will of my own—I followed this old devil's words—" He saw Alak and snarled. "*Hypnite!*"

The Patrolman stepped forth and bowed to the king. "Your majesty," he said, "Sir Varris-that-was had first

choice of blades. But if you wish to inspect them again, I have them here."

It had been easy enough, after all: two swords with retractible hypodermic needles, only they wouldn't do you any good unless you knew of them and knew where to press. The flitter's machine shop could turn one out in a couple of hours.

Alak handed them to the king from beneath his cloak. Morlach stared at the metal, called for a pair of gauntlets, and broke the blades in his hands. The mechanism lay blatant before him.

"Do you see?" cried Varris. "Do you see the poisoned darts? Burn that rogue alive!"

Morlach smiled grimly. "It shall be done," he said.

Alak grinned, and inwardly his muscles tightened. This was the tricky point. If he couldn't carry it off, it meant a pretty agonizing death. "My lord," he answered, "that were unjust. The weapons are identical, and Sir Varris-that-was had first choice. It is permitted to use concealed extra parts, and not to warn of them."

"Poison—" began Morlach.

"But this was not poison. Does not Varris stand hale before you all?"

"Yes—" Morlach scratched his head. "But when the next engagement is fought, I shall provide the swords."

"A monk," said Gulmanan, "may not have private quarrels. This nov-

ice is to be returned to his cell for fasting and prayer."

"A monk may be released from his vows under certain conditions," argued Morlach. "I shall see to it that he is."

"Now hold!" shouted Wing Alak in his best Shakespearean manner. "My lord, I have won the duel. It were unlawful to speak of renewing it—for who can fight a dead man?"

"*Won it?*" Varris wrestled with the sturdy monks gripping his arms. "Here I stand, alive, ready to take you on again any minute—"

"My lord king," said Alak, "I crave leave to state my case."

The royal brow knotted, but: "Do so," clipped Morlach.

"Very well." Alak cleared his throat. "First, then, I fought lawfully. Granted, there was a needle in each sword of which Sir Varris had not been warned, but that is allowable under the code. It might be said that I poisoned him, but that is a canard, for as you all see he stands here unharmed. The drug I used has only a temporary effect and thus is not, by definition, a poison. Therefore, it was a lawful and just combat."

Morlach nodded reluctantly. "But not a completed battle," he said.

"Oh, it was, my lord. What is the proper termination of a duel? Is it not that one party die as the direct result of the other's craft and skill?"

"Yes . . . of course—"

"Then I say that Varris, though not poisoned, died as an immediate consequence of my wounding him. *He is now dead!* For mark you, he has taken vows as a monk—he did this because of the drug I administered. Those oaths may not be wholly irrevocable, but they are binding on him until such time as the Council releases him from them. And . . . a monk owns no property. His worldly goods revert to his heirs. His wife becomes a widow. He is beyond all civil jurisdiction. He is, in short, *legally dead!*"

"But I stand here!" shouted Varris.

"The law is sacred," declared Alak blandly. "I insist that the law be obeyed. And by every legal definition, you are dead. You are no longer Sir Varris of Wainabog, but Brother Varris of Grimmoch—a quite different person. If this fact be not admitted, then the whole structure of Thunsban society must topple, for it rests on the total separation of civil and ecclesiastical law." Alak made a flourishing bow. "Accordingly, my lord, I am the winner of the duel."

Morlach sat for a long while. His mind must be writhing in his skull, hunting for a way out of the impasse, but there was none.

"I concede it," he said at last, thickly. "Sir Wing Alak, you are the victor. You are also my guest, and I may not harm you . . . but you have till sunset to be gone from Thunsba forever." His gaze shifted to Varris. "Be not afraid. I shall

send to the Council and have you absolved of your vows."

"That you may do, lord," said Gulmanan. "Of course, until that decreë is passed, Brother Varris must remain a monk, living as all monks do. The law does not allow of exceptions."

"True," grumbled the king. "A few weeks only . . . be patient."

"Monks," said Gulmanan, "are not permitted to pamper themselves with special food. You shall eat the good bread of Thunsba, Brother Varris, and meditate on—"

"I'll die!" gasped the outlaw.

"Quite probably you will depart ere long for a better world," smiled the abbot. "But I may not set the law aside— To be sure, I *could* send you on a special errand, if you are willing to go. An errand to the king of the Galactics, from whom I have requested certain books. Sir Wing Alak will gladly transport you."

Morlach sat unstimulating. Nobody dared move in all the court. Then

something slumped in Varris. Mute-ly, he nodded. The armed brethren escorted him out toward the space-field.

Wing Alak bade the king polite thanks for hospitality and followed them. Otherwise he spoke no word until his prisoner was safely fettered and his boat safely space-borne, with Dregs at the control panel and himself puffing on a good cigar.

Then: "Cheer up, old fellow," he urged. "It won't be so bad. You'll feel a lot better once our psychiatrists have rubbed out those kill-compulsions."

Varris gave him a bloodshot glare. "I suppose you think you're a great hero," he said.

"Lord deliver me, no!" Alak opened a cupboard and took forth the bottle of Scotch. "I'm quite willing to let you have that title. It was your big mistake, you realize. A hero should never tangle with an intelligent coward."

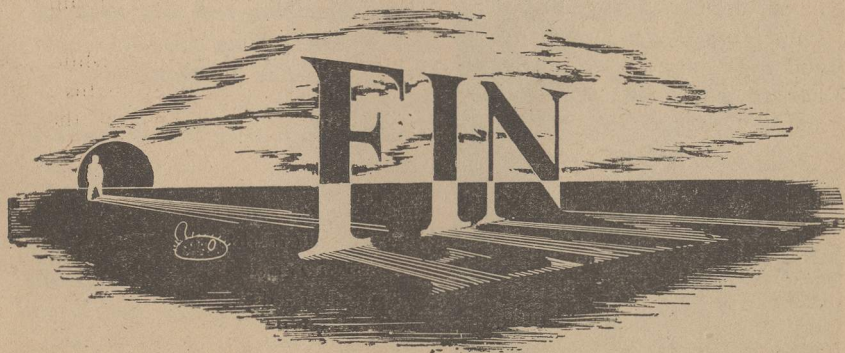

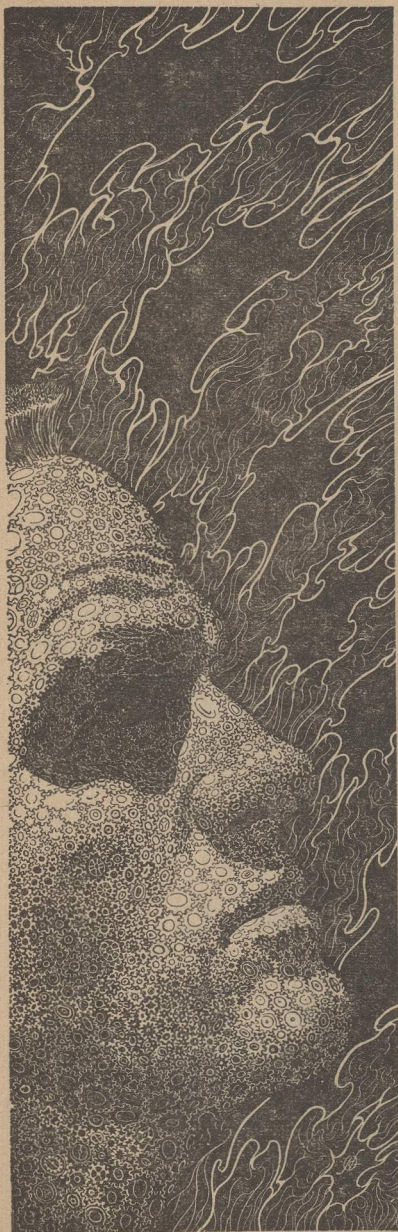

SEA CHANGE

Of course everybody knows what "being human" means—it's just that they can't define it, but of course they know what it means . . .

BY THOMAS N. SCORTIA

Illustrated by Freas

*Full fathom five thy father lies;
Of his bones are coral made;
Those are pearls that were his eyes:
Nothing of him that doth fade
But doth suffer a sea change
Into something rich and strange.*

"Ariel's Song"

—The Tempest

*Gleaming . . . like a needle of
fire—*

Whose voice? He didn't know.

The interstellar . . . two of them—

*They were talking at once then,
all the voices blending chaotically.*

*They're moving one out beyond
Pluto for the test, someone said.*

Beautiful— We're waiting . . .

waiting. That was her voice. He felt coldness within his chest.

That was the terrible part of his isolation, he thought. He could still hear everything.

Not just in the Superintendent's office in Marsopolis where he sat.

But everywhere.

All the whispers of sound, spanning the system on pulses of c-cube radio. All the half-words, half-thoughts from the inner planets to the space stations far beyond Pluto.

And the loneliness was a sudden agonizing thing, sobbing in his ear. The loneliness and the loss of two worlds.

Not that he couldn't shut out the voices if he wished, the distant voices that webbed space with the cubed speed of light but—

Might as well shut out all thought of living and seek the mindless, foetal state of merely being.

There was the voice, droning cargo numbers. He made the small mental change and the tight mass of transistors, buried deep in his metal and plastic body, brought the voice in clear and sharp. It was a Triplanet Line ship in the Twilight Belt of Mercury.

And he had a fleeting image of flame-shriveled plains under a blinding monster sun.

Then there was the voice, saying, *O.K. . . . bearing three-ought-six and count down ten to free fall—*

That one was beyond Saturn—Remembered vision of bright ribbons of light, lacing a startling blue sky.

He thought: I'll never see that again.

And: Space beacon three to MRX two two— Space Beacon Three— Bishop to queen's rook four—

And there was the soft voice, the different voice: *Bart . . . Bart . . . where are you? Bart, come in— Oh, Bart—*

But he ignored that one.

Instead he looked at the receptionist and watched her fingers dance intricate patterns over the keyboard of her electric typewriter.

Bart . . . Bart—

No, no more, he thought. There was nothing there for him but bitterness. The isolation of being apart from humanity. The loneliness. Love? Affection? The words had no meaning in that existence.

Slender fingers flicked over plastic keys and white paper bloomed endless stalks of words.

It had become a ritual with him, he realized, this trip the first Tuesday of every month down through the silent Martian town to the Triplanet Port. A formalized tribute to something that was quite dead—an empty ritual, weak, ineffectual gesture.

He had known that morning that there would be nothing.

"No, nothing," the girl in the Super's office had said. "Nothing at all."

Nothing for him in his gray robot world of no-touch, no-taste.

She looked at him the way they all did, the ones who saw past the

clever human disguise of plastic face and muted eyes.

He waited—listening.

When the Super came in, he smiled and said, "Hello, Bart," and then, with a gesture of his head, "Come on in."

The girl frowned her silent disapproval.

After they found seats, the Super said, "Why don't you go home?"

"Home?"

"Back to Earth."

"Is that home?"

The voices whispered in his ear while the Super frowned and puffed a black cigar alight.

And: *Bart . . . Bart— Knight four to . . . three down . . . two down— Out past Deimos, the sun blazing on its sides— Bart—*

"What are you trying to do?" the Super demanded. "Cut yourself off from the world completely?"

"That's been done already," he said. "Very effectively."

"Look, let's be brutal about it. We don't owe you anything."

"No," he said.

"You'd be dead now," the Super said.

"I suppose so," he said.

"You could go back tomorrow. To Earth. A new life. No one has to know unless you insist on telling them."

He looked down at his hands, the carefully veined, very human hands. And the hard-muscled thighs where the cellotherm trousers hugged his legs.

"Your technicians did a fine job,"

he agreed. "Actually it's better than my old body. Stronger. And it'll last longer. But—"

He flexed his hands sensuously, watching the way the smooth bands of contractile plastic articulated his fingers.

"But the masquerade won't work. You know that. We were made for one thing."

"I can't change Company policy," the Super said. "Oh, I know the experiment didn't work. It was a bad compromise anyway. We needed something a little faster, more than human to pilot those first ships. Human reactions, the speed of a nerve impulse, they were too slow and electronic equipment too bulky. But we weren't willing to face facts. We tried to compromise—keep the human form."

"We gave you what you needed," he said. "We gave you the pilots for your ships. You do owe us something in return. Do you think I'd have signed your contract, knowing that when I finally died, you'd put my brain in something that wasn't human?"

"Well, we lived up to the contract. We saved you from that crack-up, you and a hundred like you. All in exchange for the ability *only* you had. It was a fair trade."

"All right. Give me a ship then. That's all I want."

"I told you before. Direct hook-up."

"No."

"Look, one of the interstellar's being tested right this minute. And

there are the stations beyond Pluto."

"The stations? Why should I let myself be sealed in one of those? Completely immobile. What kind of a useless life is that, existing as a self-contained unit for years on end without the least contact with humanity?"

"The stations are not useless," the Super said. He leaned forward and slapped his palm on the surface of the desk. "You know the Bechtoldt Drive can't be installed within the system's heavy gravitational fields. The Bechtoldt field collapses explosively under those conditions. That's why we need the stations. They're set up to install the drive after the ship leaves the system proper, using its atomic motors."

"You still haven't answered my question."

"*Stargazer I* is outbound for one of the trans-Plutonian stations. *Stargazer II* will follow in a few days."

"So?"

"You can have one of them if you want it. Oh, don't get the idea that this is a hand-out. We don't play that way. The last two ships blew up because the pilots couldn't handle the hook-up. We need the best and that's you."

He paused for a long second.

"You may as well know," the Super said. "We've put all our eggs in those two baskets. If either one fails, it'll be a century before anyone tries again. We're tired of being tied to nine planets. We're going to the stars now and you can be a part of that."

"That used to mean something to me but—" He spread his hands fluidly. "After a time you start losing your identification with humanity and its drives."

When he started to rise, the Super said, "You know you can't operate a modern ship or station tied down to a humanoid body. It's too inefficient. You've got to become part of the set-up."

"I've told you before. That won't do."

"What are you afraid of? The loneliness?"

"I've been lonely before," he said.

"What then?"

"What am I afraid of?" He smiled his mechanical smile. "I'm afraid of what's happened to me already."

The Super was silent.

"When you start losing the basic emotions, the basic ways of thinking that make you human, well— What am I afraid of? I'm afraid of becoming more of a machine," he said.

And before the Super could say more, he left.

Outside, he zipped up the cellotherm jacket and adjusted his respirator. Then he advanced the setting of the rheostat on the chest of the jacket until the small jewel light above the rheostat glowed softly in the morning's half-dusk. He had no need for the heat that the clothing furnished, of course, but the masquerade, the pretending to be wholly human would have been incomplete without this vital touch.

All the way back through the pearl gray light, he listened to the many voices flashing back and forth across the ship lanes. He heard the snatches of commerce from a hundred separate ports and he followed in his mind's eye the swift progress of *Stargazer I* out past the orbit of Uranus to her rendezvous with the station that would fit her with the Bechtoldt Drive.

And he thought, Lord, if I could make the jump with her, and then: *But not at that price . . . not for what it's cost the others, Jim and Martha and Walt and . . . Beth.*

The city had turned to full life in the interval he had spent in the Super's office and he passed numerous hurrying figures, bearlike in cellotherm clothing and transparent respirators. They ignored him completely and for a moment he had an insane impulse to tear the respirator from his face and stand waiting.

Waiting, savagely, defiantly, for someone to look at him.

The tortured writhings of neon signs glowed along the wide streets and occasionally an electric runabout, balanced lightly on two wheels, passed him with a soft whirr, its headlights cutting bright swaths across his path. He had never become fully accustomed to the twilight of the Martian day. But that was the fault of the technicians who had built his body. In their pathetic desire to ape the human body, they had often built in human limitations as well as human strengths.

He stopped for a moment before a shop, idly inspecting the window display of small things, fragile and alien, from the dead Martian towns to the north. The shop window, he realized, was as much out of place here as the street and the individual pressurized buildings that lined it. It would have been better, as someone had once suggested, to house the entire city under one pressurized unit. But this was how the Martian settlements had started and men still held to the diffuse habits more suited to another world.

Well, that was a common trait that he shared with his race. The Super was right, of course. He was as much of a compromise as was the town. The old habits of thought prevailing, molding the new forms.

He thought perhaps that he should get something to eat. He hadn't had breakfast before setting out for the port. They'd managed to give him a sense of hunger, though taste had been too elusive for them to capture.

But the thought of food was somehow unpleasant.

And then he thought perhaps he should get drunk.

But even that didn't seem too satisfying.

But he walked on for a distance and found a bar that was open and walked in. He shed his respirator in the air lock and, under the half-watchful eyes of a small, fat man, fumbling with his wallet, he pretended to turn off the rheostat of his suit.

Then he went inside, nodded

vaguely at the bored bartender and sat at a corner table. After the bartender had brought him a whiskey and water, he sat and listened.

Six and seven . . . and twenty-ought-three—

Read you—

And out there you see nothing, absolutely nothing. It's like—

Bart . . . Bart—

To king's knight four— Check in three—

Bart—

And the rocks glint like a million diamonds. It depends on the way the sun comes up with—

Bart—

And for the first time in weeks, he made the change. He could talk without making an audible sound, which was fortunate. A matter of sub-verbalizing. He said silently, *Come on in.*

Bart, where are you?

In a bar.

I'm far out . . . very far out. The sun's like a pinhole in a black sheet. Did you ever train in one of the old McKeever trainers? With the black hood? I did once and there was a tiny hole in the hood and the light came through. It's like that—

I think I'm going to get very drunk.

Why?

Because I want to. Isn't that reason enough? Because it's the one wholly, completely human thing that I can do well.

I've missed you.

Missed me? My voice, maybe. You've never seen me . . . or I you—

The thought hit him that this was quite true. He should have, at least, a mental image of her. He tried to conjure one, but nothing came. She had never been, she never would be anything but a voice, someone intangible like the silent people speaking from the pages of a book."

That isn't important, is it?

Important? Perhaps not.

You should be out here with us, she said breathlessly. *They're beginning to come out now. The big ships. They're beautiful. Bigger and faster than anything you and I ever rode.*

They're bringing Stargazer I out for her tests, he told her.

I know. My station has one of the drives. Station three is handling Stargazer I right now.

He swallowed savagely, thinking of what the Super had said.

Oh, I wish I were one of them, Beth said.

His hand tensed on the glass and for a moment he thought it would shatter in his fingers. She hadn't said *on. Were . . . were . . .* I wish I were one.

Do you? he said. *That's fine.*

Oh, that's fine, starry eyes. I love you and the sky and the stars and the sense of being— I am the ship . . . I am the station . . . I am anything but human—

What's wrong Bart?

I'm going to get drunk.

There's a ship coming in. Signaling.

The bartender, he saw, was looking at him oddly. He realized that he had been nursing the same drink for

the last fifteen minutes. He raised the drink and very deliberately drank and swallowed.

I've got to leave for a minute, she said.

Do that, he said.

Then, I'm sorry, Beth. I didn't mean to take it out on you.

I'll be back, she said.

He sat, looking out over the room, for the first time really noticing his surroundings. There were two tourists at the bar, a fat, weak-chinned man in a plaid, one-piece business suit and a woman, probably his wife, thin, thyroid-looking. They were talking animatedly, the man gesturing heatedly. He wondered what had brought them out so early in the morning.

It was funny, he thought, the image of the fat man, chattering like a nervous magpie, his pudgy hands making weaving motions in the air before him.

He saw that his glass was empty and he rose and went over to the bar. He found a stool and ordered another whiskey.

"I'll break him," the little man was saying in a high, thin voice. "Consolidation or no consolidation—"

"George," the woman said gratefully, "you shouldn't drink in the morning."

"You know very well that—"

"George, I want to go to the ruins today."

Bart . . . Bart—

"They've got the cutest pottery down in the shop on the corner.

From the ruins. Those little dwarf figures— You know, the Martians."

Only she pronounced it "Mar-chans" with a spitting "ch" sound.

It's the big one, Bart. The Stargazer. It's coming in. Maybe I'll see it warp. Beautiful— You should see the way the sides catch the light from the station's beacon. Like a big ball of pure silver—

"Pardon me," the woman said, turning on the stool to him. "Do you know what time the tours to the ruins start?"

He tried to smile. He told her and she said, "Thank you."

"I suppose you people get tired of tourists," she said, large eyes questioning.

"Don't be silly," George said. "Got to be practical. Lots of money from tourists."

"That's true," he said.

Bart—

"Well," the woman said, "when you don't get away from Earth too often, you have to crowd everything in."

Bart— Uneasy.

"That's true," he told the woman aloud and tried to sip his drink and say silently, *What's wrong?*

Bart, there's something the matter with the ship. The field . . . flickering—

She started to fade.

Come back, he shouted silently.

Silence.

"I'm in the Manta business back home," George said.

"Manta?" he asked. He raised a mechanical eyebrow carefully.

"You know, the jet airfoil planes. That's our model name. Manta, 'cause they look like a ray, the fish. The jets squirt a stream of air directly over the airfoil. They'll hover just like a 'copter. But speed? You've never seen that kind of speed from a 'copter."

"I've never seen one," he said.

Beth . . . Beth—his silent voice shouted. For a moment he felt like shouting aloud, but an iron control stopped his voice.

"Oh, I tell you," George said, "we'll really be crowding the market in another five years. The air's getting too crowded for 'copters. They are not safe any longer. Why, the turbulence over Rochester is something—"

"We're from Rochester," the thyroid woman explained.

Bart, listen. It's the Bechtoldt generator, I think. The radiation— I think it's killed the pilot. I can't raise him. And there's no one else. Just instruments.

How far from the station?

Half a mile—

My God, if the thing goes—

I go with it! He could feel the flicker of fear in her words.

"So we decided that now was the time, before the new merger. George would never find the time after—"

Try to raise the pilot.

Bart . . . Bart . . . I'm afraid.

Try—

"Is something wrong?" the thyroid woman said.

He shook his head.

"You need a drink," George said.



He noticed that the glass before him was empty as George signaled the bartender.

Beth, what's the count?

Oh, Bart, I'm scared.

The count—

"Good whiskey," George said.

Getting high . . . I can't raise the pilot.

"Lousiest whiskey on the ship coming in. Those things give me the creeps."

"George, shut up."

Beth, where are you?

What do you mean?

Where are you positioned. Central or to one side?

I'm five hundred yards off station center.

"I told you not to drink in the morning," the woman said.

Any secondary movers? Robot handlers?

Yes, I have to handle cargo sometimes.

All right, tear your auxiliary power pile down.

But—

Take the bricks and stack them against the far wall of the station. You're shielded enough against their radiation. Then you'll have to rotate the bulk of the station between you and the ship.

But how—?

Uranium's dense. It'll shield you from the radiation when the ship goes. And break orbit. Get as far away as possible.

Bart, I can't. The station's not powered.

If you don't—

I can't—

Then silence.

The woman and George looked at him expectantly. He raised his drink to his lips, marveling at the steadiness of his hands.

"I'm sorry," he said aloud. "I didn't catch what you said."

Beth, the drive units for the Bech-toldt.

Yes?

Can you activate them?

They'll have to be jury-rigged into place. Quick-welded.

How long?

Five, maybe ten minutes. But the field. It'll collapse the way the one on the ship's doing.

Not if you keep your attention on it. Anyway, you'll have to chance it. Otherwise—

"I said," George said thickly, "have you ever ridden one of those robot ships?"

"Robot ships?"

"Oh, I know, they're not robots exactly."

"I've ridden one," he said. "After all, I wouldn't be on Mars if I hadn't."

George looked confused.

"George is a little dull sometimes," the woman said.

Beth—

Almost finished. The count's mounting.

Hurry—

If the field collapses—

Don't think about it.

"They give me the creeps," George

said. "Like riding a ship that's haunted."

"The pilot is very much alive," he said. "And very human."

Bart, the pile bricks are in place. A few more minutes and—

Hurry . . . burry . . . burry.

"George talks too much," the woman said.

"Oh, hell," George said. "It's just that . . . well, those things aren't actually human any more."

Bart, I'm ready . . . I'm scared.

Can you control your thrust?

With the remote control units. Just as if I were the Stargazer.

Her voice was chill—frightened.

All right then—

Count's climbing fast . . . I'll—

Bart! It's blinding . . . a ball of fire— It's—

Beth—

Silence.

"I don't give a damn," George told the woman petulantly. "A man's got a right to say what he feels."

Beth—

"George, will you shut up and let's go."

Beth—

He looked out at the bar and thought of flame blossoming in utter blackness and—

"They aren't men any more," he told George. "And perhaps not even quite human. But they're not machines."

Beth—

"George didn't mean—"

"I know," he said. "George is right in a way. But they've got something normal men will never

have. They've found a part in the biggest dream that man ever dared dream. And that takes courage—courage to be what they are. Not men and yet a part of the greatest thing that men have ever reached for."

Beth—

Silence.

George rose from his stool.

"Maybe," he said. "But, well—" He thrust out his hand.

"We'll see you around."

He winced when Bart's hand closed on his and, for a moment, sudden awareness shone in his eyes. He mumbled something in a confused voice and headed for the door.

Bart—

Beth, are you all right?

The woman stayed behind for a moment.

Yes, I'm all right. But the ship, the Stargazer—

Forget it.

But will there be another. Will they dare try again?

You're safe. That's all that counts.

The woman was saying, "George hardly ever sees past his own nose." She smiled, her thin lips embarrassed. "Maybe that's why he married me."

Bart—

Just hang on. They'll get to you.

No, I don't need help. The acceleration just knocked me out for a few minutes. But don't you see?

See?

I have the drive installed. I'm a self-contained system.

No, you can't do that. Get it out of your mind.

Someone has to prove it can be done. Otherwise they'll never build another.

I'll take you years. You can't make it back.

"I knew right away," the woman was saying. "About you, I mean."

"I didn't mean to embarrass you," he said.

Beth, come back. Beth—

Going out . . . faster each minute— Bart, I'll be there before anyone else. The first. But you'll have to come after me. I won't have enough power in the station to come back—

"You didn't embarrass me," the thyroid woman said.

Her eyes were large and filmed.

"It's something new," she said. "To find someone with an object in living."

Beth, come back.

Far out now . . . accelerating all the while— Come for me, Bart. I'll wait for you out there . . . circling Centaurus—

He stared at the woman by the bar, his eyes scarcely seeing her.

"You know," the woman said. "I think I could be very much in love with you."

"No," he told her. "No, you wouldn't like that."

"Perhaps," she said. "But you were right. In what you told George, I mean. It does take a lot of courage to be what you are."

Then she turned and followed her husband through the door.

Before the door closed, she looked back. Her eyes were filled with wonder.

Don't worry, Beth. I'll come. As fast as I can.

And then he felt the sounds of the others, the worried sounds that filtered through the space blackness from the burned plains of Mercury to the nitrogen oceans of dark Pluto.

And he told them what she was doing.

For moments his inner hearing rustled with their wonder of it.

There was a oneness then. He knew then what he must do, the next step he must take.

We're all with you, he told her, wondering if she could still hear his voice. *We always will be.*

And he reached out, feeling himself unite in a silent wish with those hundreds of minds, stretching in a brotherhood of metal across the endless spaces.

Stretching in a tight band of metal, a single organism reaching.

Reaching for the stars.

THE END



THE REFERENCE LIBRARY

BY P. SCHUYLER MILLER

THE MAN THE FANS FORGOT

At last fall's Cleveland convention, "Doc" Edward E. Smith was very much in evidence, very much a lion with the fans, as he has been throughout the nearly thirty years since his "Skylark of Space" burst on us readers of the old *Amazing Stories*. But in Doc Smith's neophyte days there were two other "Docs"—M.D.'s to his Ph.D.—who were much more prolific than he: Dr. Miles J. Breuer and Dr. David H. Keller. Dr. Breuer died in 1947 after having written some of the best short stories of the period: "The

Appendix and the Spectacles," for example, as one of the first and best stories of the mathematical—as distinct from the temporal—Fourth Dimension, and the semantic classic that antedates van Vogt's "Null-A" by decades, "The Gostak and the Doshes."

Dr. Keller is far from dead, and even though he is in his late '70s it would not surprise me to see a new story of his pop up any day in one of the magazines. He pioneered a kind of science fiction that has now pretty well taken over the dominance of the field, and he had an exasperatingly direct and simple style that

made most of his stories sound as if they were written for a Sixth Grade reader. The result was that the ideas behind the stories sometimes went right on over the heads of readers who wanted more thud, blunder and fireworks. But by the same token, few American science-fictioneers—his own term—have been more popular in Europe, and especially in France, where this same almost "Basic English" style was easy to understand and easy to translate.

Arkham House published the last and largest collection of Dr. Keller's science fiction and fantasy back in 1952: "Tales From Underwood." It was somehow packed up when I came to Pittsburgh, and never reviewed here. By now it is out of print and obtainable only from dealers, as is his other short story collection, "Life Everlasting" (Avalon, 1948) the two rather inferior novels "The Solitary Hunters and the Abyss" (New Era, 1949) and various fantasies. Only one of Doc Keller's books made the grade with a major publisher, his charming novel of a country doctor and his temptations, "The Devil and the Doctor" (Simon & Schuster, 1940).

Having at last dug out "Tales From Underwood" and reread it, I can't help reaching the conclusion that Dr. Keller wrote modern science fiction at a time when nobody wanted it or recognized it. He apparently had for years written just for the fun of writing, and it may be that he had tried all the various gambits of the field before shaping out his own

particular style and type of "Kelleryarn," but on the surface it seems that when he felt compelled to turn out more routine stories on more spectacular themes, he lost interest and soon quit. At any rate, those stories—like the giant insect melodrama in "The Solitary Hunters"—which were most like those other people wrote, were least like the really top-notch Kelleryarns, and his least memorable work. On the other hand, such books as "The Eternal Conflict," "The Lady Decides," and "The Homunculus," apparently written with no regard for marketability, are also not too successful from my point of view.

Dr. Keller really took over two related but dissimilar sectors of the science fiction and fantasy of a quarter-century ago. As a psychiatrist—and long-time country doctor before that—he wrote a series of short horror stories that prized at the crevices in the precarious mental structure most of us erect about our lives. His all-time classic, "The Dead Woman," can be read either as a horror-fantasy that outdoes Poe's "Facts in the Case of M. Valdemar," or as an extremely subtle kind of science fiction which recreates a horrible obsession. "A Piece of Linoleum," the final tale in the "Underwood" collection, is a quietly horrible portrait of an unbearable woman who is quite unconscious of her nonhumanity.

That deceptively simple style served these stories well, as it did the out-and-out fantasies like "The

Bridle," which literally crept up on you, so innocently and blandly did the narrative jog along toward its horrid and inevitable final climax.

But the stories that get into the final anthologies of anthologies, along about 2000 A.D. when some publisher decides to look back over the century, will be Dr. Keller's sociological comedies and satires. Lighter-handed than, say, a "Space Merchants" or a "Gladiator-at-Law," they were none the less merciless in their extrapolation of the trends of the late 1920s and early '30s to ridiculous or bizarre conclusions. "The Revolt of the Pedestrians," for example, written at the beginning of the automobile era when in my part of rural New York State—and I suspect in Dr. Keller's corner of rural Pennsylvania—most roads were dirt, impassable in wet weather, kept open and passable when they were by the local farmers in part payment of taxes: we haven't started to lose our legs—far from it, I attest every windy day!—but if war does bring a wholesale evacuation of our cities it will be our feet and legs that break down, not our courage. Then there is "The Psychophonic Nurse," an acid commentary on the effects of lack of mothering, written at a time when child psychologists were first launching the "let them cry" philosophy from which they have now so violently, and so late, retreated. "A Biological Experiment" is a companion-piece, the story of a young couple who attempted the amazingly archaic experiment of marrying and having a

baby. "Free as the Air" is a slap at the national philosophy of greed.

Apart from the game of playing with possibilities, which is an important element in both the writing and reading of current science fiction, the medium has always been excellent for holding Man and his society up before a distorting mirror, and here Dr. Keller has been a pioneer. Where others did it crudely, he was smooth. Where others were tortuous, he was direct and simple. His approach was that of leading you into a maze by the hand, strolling pleasantly up one alley and down the next—then suddenly letting go, and challenging you to find the way out.

Fans may not read Doc Keller any more—they may not even pick up his books in the secondhand stores—anyone got a "Sign of the Burning Hart"?—but those of us who read him when his stories were new, will never forget them.

* * * *

A little clarification of the list of twenty-five "best" SF books I have asked you to name. Deadline for your lists, you'll recall, is the first weekend in June.

I want science fiction, not fantasy—but you will have to draw the line for yourself. On debatable titles, the way most of you do draw the line will determine the placing of a book. My own criterion is intent: except for "Ship of Ishtar" and the two "Witch" books—on which there may be argument—I consider all of Merritt eligible. He wrote of his strange

races and forces as if they could and did exist. Same goes for Burroughs' Mars books: they're *fantastic*, but not fantasy. Spooks, gods, demons, the supernatural, rule a book out.

Anthologies, short-story collections, are very eligible. They were used in our last poll for two purposes. They gave you a chance to include most of the stories of an author you liked ("Short Stories of H. G. Wells") and they gave you a chance to have a large number of good stories by writers who have never done much with novel-length books.

I can't, however, yield to the plea made both last time and now, that the entire Burroughs "Mars" series, the "Skylark" series, the "Lensman" series be considered one title. If a publisher puts 'em in an omnibus, as was done with seven of the Wells novels, fine and dandy—but not otherwise.

Last week I tried, at the monthly meeting of the Pittsburgh Science Fiction Association, to put together a composite list. It won't work. Too many individual variations in taste are represented in any such group. However, the discussion did turn up some titles which members had forgotten, and I hope it will produce more individual lists. The more I get, the more work for me to analyze them, but the more valid the final composite will be as the opinion of you-all.

* * * *

The World Convention comes back to New York—the Biltmore is,

barring more changes, the convention hotel—for the Labor Day weekend. More vacation lost there: I hope to come early and/or stay a few days late, enjoying New York. Send your \$2 registration fee to the 14th World Science Fiction Convention, P. O. Box 272, Radio City Station, New York 19, and you'll get all the details directly from the Committee.

And an announcement: a Pittsburgh fan, Jack Herzog, is undertaking a two-year (1954-1955) index to the science-fantasy magazines, as a kind of supplement to the Day "Index" and to the 1951, 1952 and 1953 compendia which other fans published, and which I have not seen. He expects it to be lithographed in much the style and size of "Inside"—the former "S-F Advertiser". Price, since it will cover two years, probably \$1.00. Write to: John E. Herzog, 938 Pine Avenue, Pittsburgh 34, Pennsylvania, for information or to place orders.

HIGHWAY OF THE SUN, by Victor W. von Hagen. Duell, Sloan & Pearce, N. Y.; Little Brown & Co., Boston and Toronto. 1955. 320 pp. Ill. \$6.00

If you have any interest in the amazing civilization of the Incas, which at the time of the Spanish conquest of South America extended its overlordship from Equador to Chile, you should read this account of the two-year expedition which

ASTOUNDING SCIENCE FICTION

traced the main network of the Inca highway system. On the other hand, I'd advise waiting for von Hagen's scientific report on his investigations, which presumably will one day be forthcoming, if you want to learn very much about the roads themselves.

This is essentially a travel book, with skillful use of excerpts from the Spanish chroniclers, a good eye for the country, and just enough re-creation of the life and works of Inca and pre-Inca times to make you wish there was more. And the maps, for a book on a geographical study, are very sketchy and often do not show the places described.

Roads and trails have long been the chief linking element in widespread political units such as the Persian and Roman empires, but the Inca's road system put them all to shame. There were two trunk highways running north and south, one along the coast, the other in the highlands. There were innumerable crosslinking roads, and others running out to outpost cities of hewn stone now lost in the edges of the Amazon jungle. Way-stations at short intervals sheltered the Inca's corps of *chasquis* or runners, who carried messages—and even fresh fish—over amazing distances at sprinting speed, but a kind of relay-race system of short bursts.

The roads were an engineering marvel, too. They invariably took the shortest course over desert and plateau, climbed mountains with flights of steps or tunneled through,

spanned chasms with swinging bridges of vine ropes which remained in use for centuries through a program of constant repairs. They were rarely paved, though in marshy areas great causeways carried the road; they were, however, paralleled by walls which made the road's course clear even when desert dunes were continually overwhelming it.

The photographic illustrations are excellent and excellently reproduced; my objection is that many of them are too small, and other important features—especially those dealing with the structure of the road—are not shown at all. Perhaps these pictures were among the things lost when disaster nearly trapped the expedition.

I hope that—as is usually true of American Geographical Society expeditions—there will be a technical book in time.



PREFERRED RISK, by Edson McCann.

Simon and Schuster, New York.

1955. 248 pp. \$2.75

This novel won \$6,500 from *Galaxy* and Simon and Shuster, and I can only suppose it was for two reasons: first, it followed the formula which Fredrik Pohl and Cyril Kornbluth created for the magazine with "Gravy Planet" ("The Space Merchants"); and second, none of the better books of the year were submitted (since Horace Gold is too smart an editor to have turned them down).

This carping criticism out of the way, I have to admit that it's not a bad book and with less exciting predecessors would have been a good one. It's a perfectly legitimate "if" extrapolation, in which the Carmody Company, ultimate in insurance companies, has pursued our current passion for security to its logical conclusion by wrapping up every phase of life on a premiums-and-dividends basis. Your Blue Plate policy feeds you—at whatever level of monotony your premiums allow—anywhere in the world. Blue Heaven keeps a roof over your head. Blue Bolt's war-and-disaster coverage ballooned to the point where the Company is undertaking to prevent war.

Tom Wills, young American Claims Adjuster, arrives in Naples to take on a new and rather indefinite job. He finds himself up to his bewildered ears in violence and intrigue. A bizarre creature who regenerates his mangled body as fast as he is hauled out from under trucks, trains and steam-rollers—while the Company pays handsomely on his latest policy—becomes somehow entangled with the girl, Rena dell'Angela, whose revolutionist father is in the Company's suspended animation vaults undergoing a cure for radiation exposure which she insists he never had. And Wills, once a temporary rebel against the creed of Company Goodness, is willy-nilly dragged into the midst of it all.

Although it's all very logical, this insurance-oriented world never comes to life as did the Pohl-Kornbluth

world run by advertisers. There's less color, less vigor, less outrageous counterpoint of illogic with logic. The freakish Zorchi has his useful place in the plot, but never really belongs in it: he could be left out entirely, and the story would be little changed. A good story, certainly: nobody would have written it twenty years ago, in the "great" years of SF. A prize-winning story: well, it was their money.



ADVENTURES ON OTHER PLANETS,
edited by Donald A. Wollheim.
Ace Books, New York. 1955. 160
pp. 25¢

There are only five short stories in this original Ace collection, two of them from this magazine. One is van Vogt's excellent but by now over-familiar "The Rull." The other is Clifford Simak's "Ogre" (1944) about a group of traders who buy symphonies from a planet of musical vegetables: an odd, pleasant, imagination-tickling yarn that won't win any literary awards but should have been anthologized long ago.

The other three originated in *Startling*, which has had an enviable reputation for maintaining a middle-of-the-road policy of strong plot and action without much pioneering, but with lots of the "good old" qualities of color and wonder. Roger Dee's "The Obligation" has a Galactic surveyor contacting human outposts on a storm-tortured Venus. Robert

Moore Williams' "The Sound of Bugles" takes us to Mars, and a hungry lot of Terrestrials trying to steal the secret of Martian technology by fair means or foul. Murray Leinster "Assignment on Pasik," least of the five, is a pleasant little yarn about the devious means a Space Patrol agent has to use to clean up a bad situation.

Good time-passer, and a good enough introduction to spacers for newcomers who may be attracted by an excellent Mel Hunter cover.



REVOLT ON ALPHA C, by Robert Silverberg. Thomas Y. Crowell Co., New York. 1955. 148 pp. \$2.00

According to the publisher, this juvenile interstellar story is aimed at ages twelve and up. In color and action the age-level may be right, and the general level isn't too far wrong, but the motivation is hopelessly confusing to be launched at youngsters of sixth grade level.

Larry Stark is a cadet in the Space Patrol, on a cruise to the human colonies on the fourth planet of Alpha Centauri. He gets there after typical mishaps in space, pretty well handled as to reality, to find the colonists in revolt against Earth. Some of his closest friends "desert" to the rebels, and the Patrol is prepared to wipe out an entire colony as a disciplinary measure, so Larry, too, goes over. Why? We never really

know, except that the Patrol seems inhuman; nor is the colonists' cause for revolt ever clearly stated, except to suggest vaguely that there is a parallel with the American Revolution. This is precisely the kind of vague attitude toward just causes and underdogs that produced a lot of bewildered fellow-travelers for Communist-front activities. I'm not arguing against the theme, which we've all used from time to time, but reasons and motives ought to be very clear for kids of twelve.



SPECIAL REVIEW

STORIES, by I. Yefremov. Foreign Languages Publishing House, Moscow, 1954. 260 pp. Translated by O. Gorchakov. (\$2.98 from P. Tailer, 214 E. 15th Street, New York 3, New York)

This is a one-man collection of eight Soviet science-fiction stories; and, as far as I know, the first extensive sample of its kind available in the United States.

I read it with purely professional interest. That is to say, I was concerned with what Mr. Yefremov was trying to accomplish, and how he went about it, rather than with the literary quality or entertainment value of his work. I propose to speak of it on the same terms.

As for the literary flavor, it's antique to American tastes. In a short autobiographical foreword, Mr. Yef-

remov describes his work thusly: "I am fully aware that my descriptive style has its faults, that my heroes are often too much alike, that the psychological line is inadequately developed—" This is an acute self-criticism, and will make it easy for the book to be dismissed in a few pithy sentences by those reviewers who care to do so. But Mr. Yefremov's awareness of these shortcomings doesn't seem to have kept him from producing a large volume of work, nor does it seem to have stayed the Foreign Languages Publishing House from picking him as, presumably, a typical Soviet science-fiction writer. There must be some element in these stories which makes them, by Soviet criteria, excellently adapted to the purpose Soviet science fiction is to serve.

I see no point in summarizing the plots of the individual narratives. One of them is much like John Taine's "Before the Dawn," and another bears certain resemblances to Schuyler Miller's "Sands of Time." None of them will interest an American reader in search of simple entertainment. But they do have four universal elements in common, and in those four basics is, I think, the meat of Mr. Yefremov's message.

First, they share a common general locale. With one exception, which takes place partly in Russian territorial waters, all are located within the bounds of the Soviet Union, usually in the remoter Asiatic Republics, and, all of them take place in the present or recent past.

Second, all the central characters, male and female, are either Soviet scientists or their assistants, again with the exception of that same one story, which ends inconclusively, has no discernible point, and which seems to be a very early effort of Mr. Yefremov's. And it features Soviet engineers and other technical personnel in the only active roles.

Third, the motivating force is always discovery and exploration for the benefit of the Soviet Union. The plot invariably resolves with the discovery of a mineral deposit, paleontological find, or property of nature which will be of great benefit to the Union. All the characters, central and subsidiary, derive all their satisfaction from this climax. The subsidiary characters; collective farmers, miners, other workers, and the frequent native guides, co-operate to the utmost with all scientists, whom they admire, and whose successes make them happy. There are three love sub-plots scattered among the eight stories. All of them can resolve happily only if the scientist hero achieves his goal.

(There is a further sub-correlation. Quite frequently, the native guides refuse, in broken Russian, to enter "the place of evil spirits," et cetera. When the basis of their superstition is shown to be a phenomenon of Nature, they are much heartened, and admire the scientists even more. There is one exception to this—the native guide's fears prove right. But in this case, the evil force is not held by him to be the work of spirits or

demons. It is a hitherto undiscovered property of Nature.)

Fourth, the stories are packed with the raw stuff of the "sense of wonder." Mr. Yefremov is frequently didactic and discursive. He has a positive fondness for the exclamation point following any statement of scientific fact, and he makes quite a few of those, some of them, in the case of a brush with the speed of light, dubious, but most of them, dealing as they do with the geology and paleontology in which he is a retired specialist, quite right-sounding.

Nevertheless, the cumulative impact of all those clearly indicated enthusiasms for the wonders of Nature is enough to make any reader jump! The pace of the stories is not particularly fast—it seems to take Mr. Yefremov forever to arrive at the first segment of his plot—but that ruthless march of facts, each with its charge of communicated excitement, which characterizes his technique, is irresistible after a while. It takes resolution to begin one of his stories; at least, if you're a modern reader of some of the accomplished sweepers-off-your-feet such as Sturgeon or Heinlein who have pushed the narrative technique to a high state of evolution. But once re-acclimated to the slower initial pace of Mr. Yefremov's stories, any reader may probably not be entertained, but he will be overwhelmed.

This is no place to debate the nature of the "sense of wonder" or its metamorphoses in Western science

fiction since modern American and English writers moved away from the exclamation point technique. What is important to this review is the fact that Mr. Yefremov is good at it, however crudely he does it. And I think we may assume that he says the proper things, while saying them in the proper way. I think that therein lie the standard of achievement and criterion of success as a Soviet science-fiction writer which Mr. Yefremov has met.

All right, *why* do Soviet science-fiction writers do things this way?

The Soviet Union has an internal problem unlike in degree to that of any principal nation today. In a world where the competition between social systems rests to a major degree on the technological status of the rival systems, the Soviet Union contains large populations, particularly in the Asiatic areas, which have made no substantial advance over their technological level of a thousand years ago. Some, in fact, have retrogressed. Most of them long ago reached a balance between their accustomed way of life and the small number of tools needed to sustain it, and are contented in this condition, as any group which has lived more or less the same way for generations is almost sure to be. A great deal of effort has been expended toward introducing modern machinery, modern agricultural methods, modern educational systems, and modern attitudes of thought. But it seems likely that, in dealing with people who are *not* "modern" in their basic attitude

toward Nature and the universe, that all of these measures suffer considerable attrition from being forced into a cultural matrix never built to receive them.

There's a subsidiary cultural effect, as well, this time in the old metropolitan centers of European culture. For all that the revolution is in its second generation in most of the western Soviet republics, a good deal of what a Marxist scholar would call the "petit bourgeoisie" attitude must still be well-entrenched. In those segments, the Doctor Professor and his learning are held in great regard, but most of the more talented young people would tend to enter the time-honored professions: medicine, law, civil service, or, in a more recent development, would try to get into party politics.

But what Russia needs most of all today, is not an abundance of farmers, miners, doctors, lawyers, or civil servants. What it needs is technicians, preferably in the physical sciences. These it must have, despite the tidal drag of an opposite cultural orientation.

Therefore, Mr. Yefremov, and, we presume, the other Soviet science-fiction writers in the sixty-odd magazines specializing in the subject within the Soviet Union, are constantly making these points:

The territory of the Soviet Union contains innumerable discoveries waiting to be made and resources to be discovered. (Mr. Yefremov's heroes also easily invent new appa-

ratus to further this end whenever the situation calls for it.)

Science is personified by dedicated men and women, most of them young, in the foreground of the battle for the supremacy of the "new way of life." It is a mark of distinction to be a Soviet scientist; everyone admires a scientist, and scientists are heroes of Soviet culture.

Science is exciting; science is a rush toward the future, an explosion of the adventurous, creative spirit, made possible by iron determination to win out over all obstacles for the sake of the Soviet Union.

And all this is said with the concomitant ability to make the reader *feel* it. It's a pile-driver technique, but, with no snobbery whatsoever intended, I rather think subtlety would be wasted on the young men and women of Uzbekistan or the youngsters in the Leningrad primary schools, where career choices are made early.

How effective is this technique?

It's hardly a clear-cut case. A number of other pressures, in addition to the relatively subtler method of persuasion through science fiction must be in use. But, while an outside pressure can mold you, only the persuasion which gets you to see things for yourself can make you change your cultural attitude, and *want* to be a technician.

Russia is training twice as many engineers as we are.

ALGIS BUDRYS.

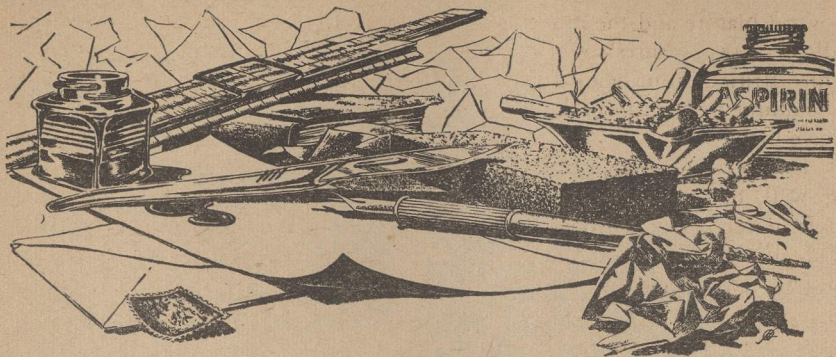

BRASS TACKS

Dear Mr. Campbell:

I feel that I must write and congratulate you on the January issue of your magazine. As I gradually have read each article, it has been a joy.

I started by finishing "Under Pressure," a serial which held my attention throughout. The captain's thoughts on a man finding the right ocean in which to navigate, and sanity being "the ability to swim" struck me as being sound and good theology.

Your editorial had a good point in saying we can't do anything but experiment with human beings. I would remind you though, that there are men who have set themselves to the very task which your article points up, that of making knowledge found by social science, as well as that of theology and philosophy, understood and accepted by

human beings. I know many ministers whose aim in life could almost be defined as this. In dealing with what they have to say, the question is often raised by scientists, "What is knowledge, and what is just the opinion of our culture?" I think that you and others would find the book "Agapé and Eros" very helpful in answering this question; at least to the degree it can be answered.

"The Executioner" and "Indirection" were good stories of the usual type, but "Won't You Walk" rose above them as a little gem of psychology. "Labor of Love" was interesting as far as it went, but I think that Mr. Leinster stopped too soon. When he says that he does not want to go into theology because that "is one of those uncomfortable things that suggest that one should do something" he has in fact (as Rich-

ard Niebuhr pointed out to my class several years ago) adopted a theology: a theology of doing nothing. Of course he did write the article pointing up the problem, and that was something.

While I'm at it I'll mention two articles from the December issue, too. "The Golden Judge" was loved by the Jewish chaplain here, and I think "Breakaway" should be required reading for all Air Force wives.—Richard Boeke, Chaplain (1st Lt.)

It's unsafe to accept what a man says he does as being what he actually does. Would you say that a man who wrote as long and prolifically as Leinster, really did nothing about his beliefs?

Dear Mr. Campbell:

It has been years since last I dropped you a line. Your editorial in the February, 1956, issue on Psionics however, has bestirred me.

By all means give us those articles on this "new science." Never mind how impossible it may seem. Isn't science fiction, itself, an "impossible" literature? This should give those of us with an experimental aptitude and attitude something to sink our teeth into. Instead of standing on the sidelines it gives us a chance to get into the fray.

As psionics and electronics appear to be tied up in this thing together, I, for one, should be able to follow

along, for a little ways, at least. My profession, radio and TV service, should, at least, give me the background to understand what is being explained. And if some of the articles actually do give us something concrete to experiment with, all the better. I got started building my own radio sets, and even yet, build up various little testing "gimmicks" to fit the bill when nothing commercial is handy when needed. So if psionics depends on electronics, it should appeal to the experimenter within me.

So go ahead. Get us the dope. Show us the pictures. Draw us the diagrams. Don't spare the horses and let the devil catch the hindmost. At the very least, it should be a lot of highly intelligent and intellectual fun.—Leslie A. Crutch, Box 121, Parry Sound, Ontario, Canada.

Coming Attraction: You can try building the Hieronymous machine!

Dear Sir:

Reading your "Science of Psionics" editorial, please note the following:

In a book, "A Night to Remember," by Walter Lord, the following is taken from the "Foreword":

"In 1898 . . . Morgan Robertson concocted a novel about a fabulous Atlantic liner . . . loaded it with rich and complacent people and then wrecked it one cold April night on an iceberg. ***On April 10, 1912, the *Titanic* left Southampton."

Below are comparisons:

Robertson's fiction boat *The Titanic*

Name	<i>Titan</i>	<i>Titanic</i>
Displacement	70,000 ton	66,000 ton
Length	800 feet	882.5 feet
Type	triple screw	triple screw
Speed	24-25 knots	24-25 knots
Capacity	3,000	3,000
Disaster	iceberg— April	iceberg— April 14, 1912

Between the two dates 1898 and 1912 fourteen years passed. Coincidence or psionics?—Raymond Wittl, Jefferson, Wisconsin.

Aww—be just guessed!

Dear Mr. Campbell:

Having got out my electronic equipment and surplus parts, along with a large supply of well-sharpened pins and recent photographs of several of my most enterprising competitors, I am eagerly awaiting publication of your first article on psionic machines.—William E. Lingrel, 1183 Aberth Drive, Akron 20, Ohio.

Unfortunately, it's a necessary fact that any powerful useful tool is a powerful and dangerous weapon, when misused. Let's not deny that psionics, if it is real and powerful, is also really dangerous.

Dear Mr. Campbell:

I sit before the typewriter grimly

determined actually to write a letter. I plan many letters and never write them, but on *two* occasions lately I have been prompted to write you, and now I shall do so even though it is proving difficult to begin.

The first instance was your "design Flaw" article in which you discussed hypnotism while driving. I should like to express my sympathy and regret that it had to strike you so closely, and I agree wholeheartedly that it should not be allowed to continue. I also have no doubt that the only way to achieve a true and complete solution to the problem is through research into the nature of hypnotism, but, if this research should take as long to produce anything as that for the cold has, the problem will be before us for a great many years. In addition, there is little that just plain driving experience—which is all I have to offer—could contribute to such research. Therefore, my points deal only with the "pragmatic" approach, my attempts to solve a problem which I do not understand but the results of which I do understand.

I do not know what studies of the effects of car radios have been, you mention in this last issue that radios do not seem to help much, but I have got a great deal of good out of mine on long drives by listening to programs I don't like, or with which I can argue, or which are exceedingly stimulating. I am careful never to listen to music although this is my preference in all other circumstances. Radios, however, in this country are

somewhat limited because the stations are rather far apart, have a limited range, and frequently have to contend with mountains.

Even better than the radio, I find, is singing. Of course, my voice would keep anyone awake, but I think the real value is derived from trying to think of the words. I don't care much for popular music, so the lyrics don't come to my mind readily and I must either search for them or invent new ones. This device I acquired before and during the first part of WWII in which I drove Army trucks frequently on long monotonous convoys, and I know that most of the other drivers sang also. A "break-in" convoy at 25 mph for five hundred Texas miles would hypnotize anyone, so I sang, told myself stories, and even managed to get in a little reading—although this last expedient I would not recommend to anyone.

The common denominator here is to keep the mind "self-conscious"—I don't know what the term should be—aware of the fact that it can be deluded, and that it must keep itself alert. For this reason, I think that your article is one of the best means of solving the problem on the pragmatic level. I strongly suspect that the very knowledge of the danger will tend to make people find their own measures. I should like to see a great deal more publicity given to the danger, but I would rather that it be an excuse for more interesting radio programs than more billboards. I don't feel, however, that the situa-

tion can be taken care of automatically with beeps, burps, or "warning" devices, because these, as you pointed out, can be all too readily ignored. It seems to me that the solution must rest with keeping the mind alert all the time, not with trying to "awaken" it after it has been hypnotized.

The second instance is your article in the present issue of *Astounding* on psionic machines. I should like very much for you to print such articles, but I should like (a) assurance that there will be no deliberate hoaxes, and (b) validation of some kind. My credulity surpasses even my own belief at times. I didn't hear the famous Orson Welles broadcast, but if I had I'm sure I'd have been taken in by it. Some years ago there was a hoax article about a rocket to Venus and a break in the clouds there which revealed a large mountain and incidentally the revolution of that planet. This I believed, and was quite shaken to learn that I had been taken in by it part and parcel.

Consequently, I hope that you will bear in mind that my knowledge of these things is slight and my opportunities for verification are even slighter. I wouldn't know a hoax if I stepped on it.

For the (b) portion, I don't expect you to assume personal responsibility for the author and his work, but I would like to know a little something about him in order to be able to form some sort of an opinion. I can't tell you what it is I would like

because that would depend on the particulars of each instance, but if you will just bear in mind my—and possibly other's—fairly complete ignorance of the subject, and try to give some background for the material, I'm sure it can be handled.—
John M. Kaufman, 4518—16th Avenue NE, Seattle 5, Washington.

1. *I feel your comments on highway hypnosis makes sound sense. I use similar devices myself.*
2. *I'll try to fulfill the specifications for psionics articles. They'll be labeled as what they are—speculative psionics material. Since there are no experts in this field, verification is going to rest with you personally, as much as with anyone else. You have to be a responsible fellow—researcher!*

Dear Mr. Campbell:

Please vote AYE several times on the psionics machine articles in my name. It's a time hallowed custom in New Mexico, and I live and vote here, so am entitled to several votes.
QED

Suppose I do go broke trying to build a gadget. I've gone broke many times for lesser causes. I love hitching my wagon to a star, even though the record—real political, this epistle—shows it usually comes home with wheels wobbling, sideboards gone, and axles bent to hell, the rides have not been boring.

Your editorial is, as always, well written. You have pointed out lucidly

BRASS TACKS

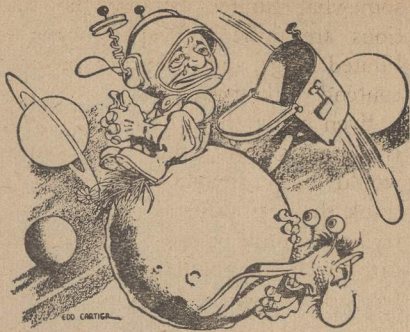

MOVING?

*Going to have
a new address?*



We can't send your regular Astounding SCIENCE FICTION along if you don't warn us ahead of time. If you're going to move, let us know six weeks in advance. Otherwise you'll have a neglected mailbox!



Write SUBSCRIPTION DEPT.
Astounding SCIENCE FICTION
304 East 45th Street
New York 17, New York

the implications of these articles, and if someone should be burned—even if that someone be me—I still vote **AYE**. Burned fingers are infinitely preferable to diapers or rigor mortis. So this field is peculiarly susceptible to the “lunatic fringe”—to shun honest research for that reason would be to deny the validity of research itself. We do not disdain the conflicting findings of psychology because mail-order diplomas are peddled.

Get the articles, publish them and give we who are not so original a chance to compare, wrestle with—and mayhap supply some small measure of the climate wherein further experiments can be made.—Alice Bullock, 812 Gildersleeve, Santa Fe, New Mexico.

That isn't the scientific attitude, that develops the known; it's the amateur attitude that harnesses the Unknown!

Dear John:

The recent hullabaloo about psionics looks intriguing, and I have the idea that there may be some good work hiding in the hinterlands. Fine idea about the series of reports, and you can count on this letter to turn out to be one vote positive, even though the rest of it is devoted to qualifying that vote.

A fellow in England named Tromp has written a book called “Psychical Physics”—it's an excellent compendium of psychic-type experiments with fairly complete descriptions of experimental conditions. It's

available over here, and I recommend it as a good source of psientific experiments on which to practice evaluating.

The biggest criticisms I could level against the experimenters have little to do with whether the results are explainable or not in known scientific terms. Rather, they concern the *omission of essential controls* and *ignorance of the properties of their equipment*.

A good example of the first category of mistake occurs in the experiments on homeopathic doses of drugs. Homeopathic doses are doses in exceedingly small amounts—certain marked effects are claimed when the concentrations administered go below a certain minimum. These doses are obtained by successive dilutions of solutions of the substances to be administered—the dilutions are carried out until fractions as small as 10^{-30} of the original amount of drug remain.

Now I wouldn't call any sincere man a liar for reporting the results he observed, “sensible” or not, but I would like to know how you administer less than a millionth of a molecule of a substance! Even if we junk molecular theory, it doesn't seem likely that you could purify water to the extent where you could say with confidence that the final solution contained 10^{-30} moles of your drug and absolutely nothing else.

The second category—ignorance of properties of instruments—I have run across several times. One gadget I saw was purported to “tune in” on

different diseases. This machine connected the patient into a Wheatstone bridge and the unbalanced voltage was amplified and presented on a flashy meter. There were several colored lights on the front which were run directly off a filament transformer and did nothing at all. You may recognize this device as one for measuring skin resistance, which correlates in a vague sort of way with general health, all right, but in no usefully predictable way. The "tuning-in" claim was hogwash. There wasn't a tuned circuit, LC or RC or otherwise, in the whole arrangement. Yet the man who explained it to me believed what he said.

Another example—an "aura detector." This one used a piece of pottery to detect the aura. There was a voltage applied through a high resistance to the pottery-shard, and a DC amplifier was connected to read the voltage across the resistor. You guessed it—a very neat humidity detector. Breathe on it and the needle slams over to the stop—look at all that Life Force! Formula for Life Force: H_2O .

So let's have circuit diagrams for all electrical equipment, and drawings—clear drawings—of the rest, with details of construction. If your reporters will do only that, we can avoid patience-wasting boobos.—Bill Powers, 5300 Hyde Park, Chicago, Illinois.

These comments are, of course, sound. Would-be contributors please note.

BRASS TACKS

Maybe You Too Can WRITE

Yes, *Astounding SCIENCE FICTION*, like other magazines across the nation, needs stories and articles.

Who's going to write them? And be paid from \$150 to \$3,400! Have you ever stopped to figure out how many stories and articles are needed to fill a magazine the size of *Astounding SCIENCE FICTION*? Multiply that by the number of magazines published, and add in the number of newspapers; then figure the scripts required for TV, radio and motion pictures each week. Quite a total, isn't it? Someone has to write it all. And get paid for it too!

So, why don't you try to make money writing. Perhaps you are one of those people who have a flair for writing.

Your big problem may be that your work lacks the "secret" ingredients used by professional writers. What is the "secret"? Frankly, there's nothing secret about those ingredients. Most any professional fiction writer who is also a *good teacher* and is *willing* to figure them all out and *explain* them to *you* could do so—*maybe!*

Now, where can you learn these so-called secrets? Well, there are many schools. I happen to be President of one of the oldest, and while I am naturally prejudiced, I honestly believe we have the best course and the most helpful instructors in the business. Our students and graduates say the same thing. True, not everyone succeeds, but many sell when only halfway through the course, and many more become full-time professional selling writers.

As Rupert Hughes says in recommending Palmer Institute to both new and experienced writers: "Writing is one of the few arts of which much can be best taught by correspondence." And here's how we make it work: After you enroll, you are assigned a teacher who is himself a *professional* writer, who is *able* to give you the full benefit of his own experience—helping and encouraging, leading and showing the way to success.

If we don't think that you were meant to be a writer, we'll tell you, and cancel your enrollment. Nothing could be fairer. Oh, I could go on telling you about our course, but there isn't room here. Instead, I'll send you a copy of my free 40-page book, "The Art of Writing Salable Stories" and a typical lesson package. There won't be any obligation, and no salesman will call. So drop me a card today and I'll send it right away.

BARTON A. STEBBINS, Pres.
Palmer Institute of Authorship
Desk ASF-66, 1680 N. Sycamore
Hollywood 28, California

(Advertisement)

(Continued from page 5)
ity. And someone else will bumble together some haywire rig that does clairvoyance—with control-knobs.

The articles will be amateur, that means that we don't claim to be authoritative, "right," or important—and that, in consequence, we are totally disinterested in any learned discussions of how unimportant, wrong, and illogical-according-to-best-modern-concepts they are. We know that; scientists who don't like psionics are perfectly free to ignore them utterly. We're amateurs, and we're not selling a darned thing but some fun speculating.

Now there are two broad, loose generalities we can lay down as a start in this research. Highly trained, widely informed and thoroughly competent scientists have investigated the psi phenomena, and have unanimously stated that the whole thing is scientifically impossible. That's one helpful foundation for our work; whatever psionics is, we can, with high probability, assume that it is *not* explainable by the known laws of science. That implies that new, basic laws of the Universe are involved. That we can drop at the start any effort to modify the inverse square law, for instance, to make telepathy conform. Instead, we can start off by looking for radically new, and completely unknown mechanisms.

The other broad, helpful indication is the utter failure of four thousand years of mysticism. In the entire

period, many of the race's most able, intelligent individuals have devoted lifetimes of deep, conscientious and rigidly disciplined study to the problem of mystical methods of cracking this field, and have failed.

The records strongly indicate that some people are born with strange gifts—and can *do* things, but do not know how they do it. They have, repeatedly, sought to explain what they did—but have, with practically perfect unanimity, failed utterly to do so. Even Jesus was unable to teach the sincere, anxious, and believing Peter to walk on water. The mystics have, time and again, stated exactly what must be done—but have used terms like "faith," and have been unable to convey the meaning of this term to anyone else. (I can state that "To walk on water, one need only forshab mulflun, while gram-thooping scratly." Now wait till someone develops a teachable technique, and I can prove clearly that what I meant by those words is exactly what his teachable technique involves, only you, you stupid fools, wouldn't listen to me.)

Very well; if brilliant men, over many ages, haven't been able to do it that way—I think that we amateurs, who don't want to devote whole lifetimes to it, better give that method a miss. Mysticism doesn't work fast enough to be useful.

But . . . what's the essence of mysticism?

Let's put it this way; the Mystic holds that there are Powers and Forces in the Universe, that a human

being can call on. (This is the essence of the Magic concept; whether you call 'em "Powers and Forces" or "Demons and Gods" makes darned little difference.)

The Mystic, moreover, talks in terms of the essence of humanness—the soul, or Mind, or whatever his term for it may be. That it is *human-ness* that is essential, however, is the fundamental.

Look, friends; they used to say that organic chemical compounds required the presence of a Vital Essence—that only living organisms could make them. Modern plastics chemistry would never have gotten even as far as the test tube on that kind of philosophy.

Sure there are Powers and Forces in the Universe. But they're just as mechanical—just as subject to law and rationality—as are the laws of chemistry. The mystic will scream at the suggestion, but he's due for technical unemployment—just as thoroughly as the Vital Essence got unemployed by technology.

The only way that anything can be made teachable is to make it referable to an external-to-the-individual reality. Psionics doesn't refer to the material level; neither, of course, does electronics, for that matter. Electronics are necessary for the structure of matter, but electrons are not matter. They are, moreover, manipulated by even less material realities—magnetic and electric fields. Somewhere, there's a level at which the forces of psionics are as real, mechanical, predictable, and limited as

are magnetic and electric fields. They're just a different kind of field; they follow different laws, but are just as lawful.

They will not do anything you wish; they'll do what they have to. They'll disappoint you—and be useful.

Now the mystic is typified by his reiterated statement that these Powers and Forces must be approached

ROBOT SHOW-STOPPERS

Do you ever need to organize a display for a show that will STOP everybody there, and make them notice your display? Ask us about our RELAY TIT-TAT-TOE and other game-playing machines; SQUEE, FRANKEN, and other small ROBOTS (responsive, intelligent, self-acting machines.) We make them (or rent them) to your own specifications and budget. See our story in LIFE magazine, March 19, pp. 173-6. Write us for complete information: P 36, SMALL ROBOT REPORT.... 25¢

● ● ● ● ● ● ● ● ● ●
Make your own tiny genius computers—

TYNIACS (\$9.95) & GENIACS (\$17.95):

K3: TYNIAC (R) SMALL ELECTRIC BRAIN CONSTRUCTION KIT: Complete set of: over 250 parts, including four multiple switches of a new design and new wipers so that all switches work well; set of templates; and 48-page manual of instructions, by E. C. Berkeley, including introduction to Boolean algebra for circuits. With this kit you can make over a dozen ENTIRELY NEW arithmetical, logical, reasoning, computing, puzzle-solving and game-playing machines, and also over 15 Geniacs. Each Tyniac runs on one flashlight battery, requires no soldering (all connections with nuts and bolts). . . . \$9.95 (add 60¢ for shipment U. S. west of Miss.; \$1.40 outside U. S.)

P 38: Tyniac Manual alone . . . \$2.00; K 4: Set of New Improved Wipers for Geniac experiments. . . \$1.00; P 30: Geniac Manual alone . . . \$3.00; P 6: Constructing Electric Brains, reprint of 13 published articles . . . \$2.20; K 1: Geniac Kit, with six multiple switches, over 400 parts, and new wipers . . . \$17.95.

RETURNABLE IF NOT SATISFACTORY ALSO publications, courses, assistance, etc., on computers, robots, symbolic logic, etc.

We are Edmund C. Berkeley & Associates, makers and exhibitors of small robots, publishers (the monthly "Computers and Automation," P 2, \$5.50 yearly; etc.), writers ("Giant Brains," Wiley, 1949; P 40, \$5.00; etc.), consultants, instructors, etc. We offer over 30 courses, many small robots, 2 kits, and over 30 publications. Write us for up-to-date information.

MAIL THIS COUPON

EDMUND C. BERKELEY AND ASSOCIATES
815 Washington St., R 157, Newtonville 60, Mass.

1. Please send me items circled:
P 36 K 3 P 38 K 4 P 30 P 6 K 1 P 2 P 40
RETURNABLE in 7 days for full refund if not satisfactory. I enclose \$_____ in full payment (add 10¢ per item for handling and postage).
2. Please send me free announcements.
My name and address are attached.

with proper humility—but he is also typified by being a remarkably arrogant man. “I,” he says, “KNOW these things; I have Powers at my call, as I can show.”

You know, I think that what he says is correct—and would work fine if he ever tried it. Humility. Not “I” so much. *He* doesn’t do it, darn it—*it* does it!

You don’t have to be human to do it; he doesn’t Summon the Powers to Do His Bidding, dammit! If he’d stop being so blasted sure he was so all-fired important, and start studying the importance of the underlying laws, we might get somewhere. But if there’s anything a mystic hates, it’s “cold, crass, materialism—mere physical machinery!”

Look; I’m a machine. I’m a darned fine machine, too—the product of three billion years of field testing, currently getting my field-test. Each unit, down through those thousands of megayears, has been field-tested to destruction; that is what I am here for right now—testing to destruction. I’m a machine, though—physically, mentally, and psychically. By that I mean simply that I deeply and solidly believe that there are laws in this Universe that are fundamental, universal, and absolute—and that I am a product of those laws. I don’t make the laws; they make me. If I, as a human being, have psi powers—and I have reason to believe I do—then that means that there is a machine that has psi powers.

But a human being is a machine with an enormous number of differ-

ent powers; it should be possible to build a much simpler sort of machine that has any *one* of the powers a human being has.

Once, no machine could see, no machine could hear.

Once, philosophers thought that logic was a high achievement possible only to the most highly developed human minds.

The Mark IV computer, at Harvard, does faultless logic and does it enormously faster than any highly developed human mind.

Good; let’s reject the mystic’s idea that psionics is a thing involved with the essence of humanness—the Soul, or the Mystic Mind, or something. If that’s all the Soul is, the Soul is as I say, due for technological unemployment.

(Don’t worry; two centuries hence, there will be mystics violently protesting that people consider the Soul a mere psionic mechanism, the dull, crass materialists! They’ll be right, too; humanness includes something considerably more subtle than the ability to make dice do tricks, see something in a distant place, or perceive what someone else is thinking.)

So we accept the scientist’s statement that psionics isn’t scientific, and that, therefore, it lies outside of science. And we reject the mystic’s attitude, his theories, but not his data. Rational thinking may never reject data; it is always free to reconsider interpretation of data, however.

Because the mystics have gathered data for many, many centuries, their

Never, Ever Before, Anywhere!!

7000 fantasy and science-fiction books and back-issue mags at 50% to 90% under what they've ever cost you before, here or anywhere, while they last! List free.

WEREWOLF BOOKSHOP

7055A Shannon Road, Verona, Pennsylvania

data is highly useful—provided it is carefully combed out of the peculiar verbiage and imposed interpretations. The magician of old might report that So-and-so died suddenly because he “summoned a Demon too powerful for the best spells he had.” The data is unquestionably true, in many instances. Ever wonder how it was that gunpowder, which is quite hard to compound, was the first explosive known, when nitroglycerine is so easily made by mixing glycerine, nitric, and sulfuric acids—just the sort of thing the old alchemists used to putter around with?

If you described it as summoning a Demon too powerful for their best spells—or alembics—to control, you wouldn't be far off.

Don't ignore the data the mystics report; recognize it as an attempt to report an occurrence not communicable in available terminology. How would an alchemist of the Middle Ages have communicated the concept of the Law of Conservation of Energy, for example? The concept “energy” may seem simple to you, now—but let's see you point to some of this-here “energy” nonsense you're

talking about. Show me some; go ahead—point to it!

Which, incidentally, brings up another point. It's been reported by mystics, magicians, enchanters, and witch doctors down the ages that the Powers, Demons, Forces, and/or Gods involved can destroy, and do, if they are improperly or carelessly dealt with. You can, if you insist, consider that sheer nonsense. Personally, I prefer to think that they learned a real fact, by the usual bitter, sudden method. If you are making experiments, it might help others sometime if you kept copies of your progress notes at some other location. It's possible that generations of dedicated researchers were utter fools—but somehow, I can't think it probable. Old Ben Franklin's experiment with the kite, key, and a thunderstorm worked real fine for him. A lot of people know about Ben's experiment—but fewer know the fate of the several European experimenters who tried to duplicate his experiment. They got what Ben, by the law of probabilities, had coming to him. No modern scientist would consider

attempting any such hair-raising experiment.

Finally, one further comment: Several people asked for articles on tests for ESP, and many others asked for articles about devices to train ESP abilities, or to make ESP powers more useful.

I do not plan to run such material. Both of these requests involve "How can I use it," and if the record of science means anything, the necessary question is *not* that arrogant demand—but the more humble question, "How can it be used?"

Most of the ESP tests have been developed in an effort to prove the existence of the phenomena. Professionals must prove each step, and the proof must be in orthodox terms. As professionals, they must develop a test based on known techniques, and establish irrefutably that the phenomena exist.

As amateurs, we don't have to. It's a waste of time, since the spontaneous occurrences establish the existence of *something*, and that's all we, as amateurs, need. If, for your own interest, you want to test for your own psi powers—what psi power? Make up your own test. Heck, could be that your only presently-developed psi power was the ability to curdle

milk. But you might be a real superdilly at that. That, then, not a stack of trick cards, would be the place for *you* to start. If you can curdle milk, how do you do it? Change the pH somehow? Cause agglutination of the proteins? If so, can you curdle goat's milk as well as cow's milk?

Don't ask for ESP test—find out what you can do. Don't insist on the arrogant approach of "how I can use it," but accept the more rational, and more effective-in-the-long-run approach of "what can I do, and how can it be useful?"

The approach to psionics has, through the years, been that of "I want to use it," and it hasn't gotten far. I suggest it's time to find out the nature of the forces involved; neither wasting time seeking to make a reluctant audience swallow an unwelcome dose by forcing them to admit psi exist, nor waste time trying to do some predetermined thing. Don't insist that only telepathy—or levitation, clairvoyance, telekinesis, or whatever your pet—is worth working for.

If your only available psi ability is curdling milk—find out how, and why, and what its limitations are, and what the market for curdled milk is.

THE EDITOR.



TAKE ANY 3 OF THESE SCIENCE-FICTION THRILLERS

(VALUES UP TO \$10.45)

Yours for Only \$1.00 WITH MEMBERSHIP

—Continued from Back Cover

YES, YOU TAKE ANY THREE of these Science-Fiction masterpieces for only \$1 when you join this exciting new book club. The volumes shown on this page are typical selections—representing the absolute cream of science-fiction writing by top authors in the field. Each book is crammed with rocket-fast action, suspense, thrills of the future. Each is a full-size, hard-bound, colorfully-jacketed volume we *know* you'll enjoy! Yet on this amazing offer you get any three (worth up to \$10.45 in publishers' editions) for only \$1.00.

NOT THIS AUGUST by C. M. Kornbluth. A real chiller about the aftermath of a Communist invasion of America. (Fully described on other side.) Pub. ed. \$2.95.

WORLD OUT OF MIND by J. T. McIntosh. Creatures from outer space, disguised as humans, plan an invasion of Earth. And one of them has already assumed the world's highest office! (Pub. ed. \$2.75.

SEND NO MONEY— Mail Coupon NOW!

Use the coupon to indicate your choice of any 3 Science-Fiction books. One volume will be considered your first selection, for which you'll be billed only \$1 plus a few cents for shipping. The other two are yours FREE, as a membership GIFT. Each month you will be offered the BEST brand-new, full-length science-fiction novels for ONLY \$1 EACH—even though they sell for \$2.50, \$3.00 and MORE in publishers' editions. Each month's selection is described in ADVANCE. You take ONLY those books you really want—as few as four a year. But this offer may be withdrawn at any time. So mail the coupon RIGHT NOW to:

SCIENCE-FICTION BOOK CLUB
Dept. ASF-6, Garden City, N. Y.

TREASURY OF SCIENCE-FICTION CLASSICS. Four famous novels; a complete play; scores of great S-F stories, including "Invasion from Mars," made famous by Orson Welles. Pub. ed. \$2.95.

ASTOUNDING SCIENCE-FICTION ANTHOLOGY. A story about the first A-bomb, written before it was invented—Plus more than 20 other

"bests" of the past decade! Pub. ed. \$3.95.

SNOW FURY by Richard Holden. Millions are doomed when an unseasonal blizzard hits New England—and the "snow" moves against the wind and fails to melt! Pub. ed. \$3.00.

OMNIBUS OF SCIENCE-FICTION. 43 classic stories by top authors. Wonders of earth and man; amazing inventions; space travel; visitors from outer space; worlds of tomorrow. Pub. ed. \$3.50.

SCIENCE-FICTION BOOK CLUB Dept. ASF-6, Garden City, N. Y.

Please rush the 3 books checked below and enroll me as a member. One is my first selection, for which bill me only \$1, plus a few cents postage. The other two are mine FREE as a membership GIFT. Every month send me free bulletin, "Things to Come," describing coming selections. For each book I accept, I will pay \$1 plus shipping. I do not have to take a book every month (only 4 during each year I am a member)—and may resign any time after accepting 4 selections.

GUARANTEE: If not delighted, I may return all books in 7 days, pay nothing, cancel this membership.

- Astounding Anthology Snow Fury
 Not This August Treasury of S-F Classics
 Omnibus of S-F World Out of Mind

Name _____

Address _____

City _____ Zone _____ State _____

Selection price in Canada \$1.10 plus shipping. Address Science-Fiction Club, 105 Bond St., Toronto 2. (Good only in Continental U. S. and Canada.)

IT IS APRIL 17, 1965

America is Invaded by Communist Troops!

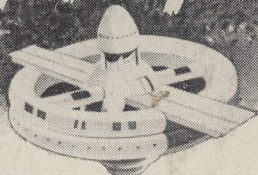

...and only the "satellite"
can save the nation now!



YOU STAND THERE DUMFOUNDED, listening to the radio: *Ladies and Gentlemen, the President of the United States...* Then, the familiar voice... *My fellow Americans, General Fraley has unconditionally surrendered the Army to Generals Novikov and Feng...* WE ARE DEFEATED...

America is at the mercy of the Red Army! And yet you retain a fragile hope! You hear rumors that our atomic scientists have hidden **TWO TONS OF FISSIONABLE MATERIAL**... enough, *if the means could be found, to reduce both nations to rubble!*

THEN YOU FIND THE MEANS! You stumble upon the lost hiding place of the top-secret **SATELLITE**. By a whim of fate, YOU have become master of the destinies of two hundred million Americans. *But time is running out...*

NOT THIS AUGUST is a chilling story, *all the more terrifying* because it could be true! And it is just one of the **THREE** full-length books you can get for only \$1.00 on this amazing offer!

ANY 3

of These Masterpieces of

SCIENCE-FICTION

Yours for Only \$1⁰⁰
WITH
MEMBERSHIP

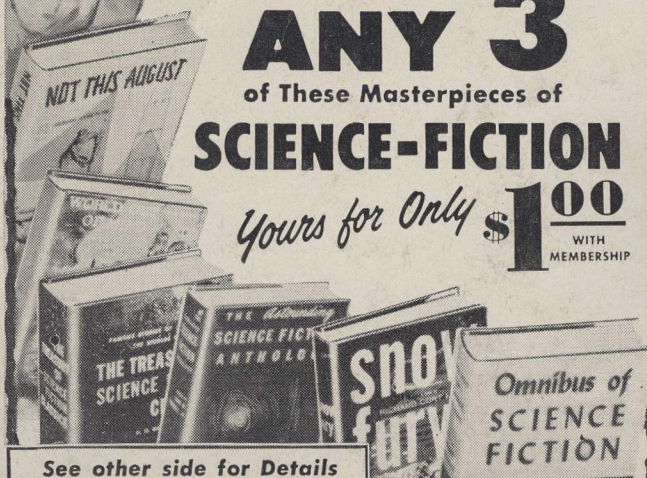

See other side for Details

STREET & SMITH'S Astounding SCIENCE FICTION JUNE 1956